

## Technical Data Manual

## TDM

Group: Chiller  
Part Number: CLIV TDM  
Date: 29 May 2023

### **CLIV Series** **Air Cooled Scroll Compressor Chiller** **Water Generator Unit**

#### **Model**

**3, 5 y 10 RT**

**Refrigerant HFC-410A**

**50/60 Hz**



**SAFETY WARNING.....3**  
**GENERAL DESCRIPTION.....4**  
**FEATURES / BENEFITS.....5**  
**TECHNICAL INFORMATION.....7**  
**DESIGN PARAMETERS.....9**  
**ELÉCTRICAL INFORMATION.....12**

**Manufactured in an ISO 9001 certified facility**



© 2023 Comfort Flex . Illustration and data cover the Comfort Flex product at the time of publication and we reserve the right to make changes in design and construction at any time without notice.

## SAFETY WARNING

This manual provides information on the technical data of the Comfort Flex CLIV series.

**NOTES:** Installation and maintenance must be performed only by qualified personnel who are familiar with local codes and regulations and who have experience with this type of equipment.

### ⚠ DANGER ⚠

LOCK OUT/LABEL all power sources before starting, pressurizing, depressurizing or shutting down the chiller.

Disconnect electrical power before servicing equipment. More than one disconnection may be required to deenergize the unit. Failure to follow this warning to the letter can result in serious injury or death. Be sure to read and understand the installation, operating and service instructions in this manual.

### ⚠ WARNING ⚠

Electric shock danger. Improper handling of this equipment can cause personal injury or equipment damage. This equipment must be properly grounded. Control panel connections and maintenance should be performed only by personnel knowledgeable in the operation of the equipment being controlled. Disconnect electrical power before servicing equipment. Be sure to install a earth leakage breaker. Failure to install a earth leakage breaker may result in electric shock or fire.

### ⚠ CAUTION ⚠

Static sensitive components. Static discharge during handling of the electronic circuit board can cause damage to components. Use a static strap before performing any service work. Never unplug any cables, circuit board terminal blocks, or power plugs while power is applied to the panel.

### ⚠ CAUTION ⚠

When moving refrigerant to/from the cooler using an auxiliary tank, a grounding strap should be used. An electrical charge builds up when halo-carbon refrigerant travels in a rubber hose. A grounding strap should be used between the auxiliary refrigerant tank and the cooler end sheet (ground to ground), which will safely carry the charge to ground. Failure to follow this procedure may result in damage to sensitive electronic components.

### ⚠ WARNING ⚠

If refrigerant leaks from the unit, there is a potential choking danger as the refrigerant will displace air in the immediate area. Be sure to follow all applicable published industry-related standards and local, state, and federal statutes, regulations, and codes if refrigerant is produced. Avoid exposing refrigerant to an open flame or other ignition source.

### ⚠ WARNING ⚠

Polyolester oil, commonly referred to as POE oil, is a synthetic oil used in many refrigeration systems and may be present in this Comfort Flex product. POE oil, if it ever comes in contact with PCV/CPVC, will coat the inside wall of the PVC/CPVC pipe and cause environmental stress fractures. Although there is no PCV/CPVC pipe in this product, keep this in mind when selecting piping materials for your application, as system failure and property damage could occur. Consult the pipe manufacturer's recommendations to determine appropriate pipe applications.

## DANGER IDENTIFICATION INFORMATION

### ⚠ DANGER ⚠

Danger indicates a dangerous situation which, if not avoided, will result in death or serious injury.

### ⚠ WARNING ⚠

Warning indicates a potentially dangerous situation which may result in property damage, personal injury or death if not avoided.

### ⚠ CAUTION ⚠

Caution indicates a potentially dangerous situation which may result in minor injury or equipment damage if not avoided.

**NOTES:** Indicate important details or clarifying statements for the information presented.

Our units are built with design and control in mind, so we use specialized technical control software. Some of our special features are our own piping and wiring, scroll compressors, new generation evaporators, air cooled condensers, optional hydraulic

components, and various safety protections.

Our units are environmentally friendly and operate with R410A refrigerant.

### NOMENCLATURE

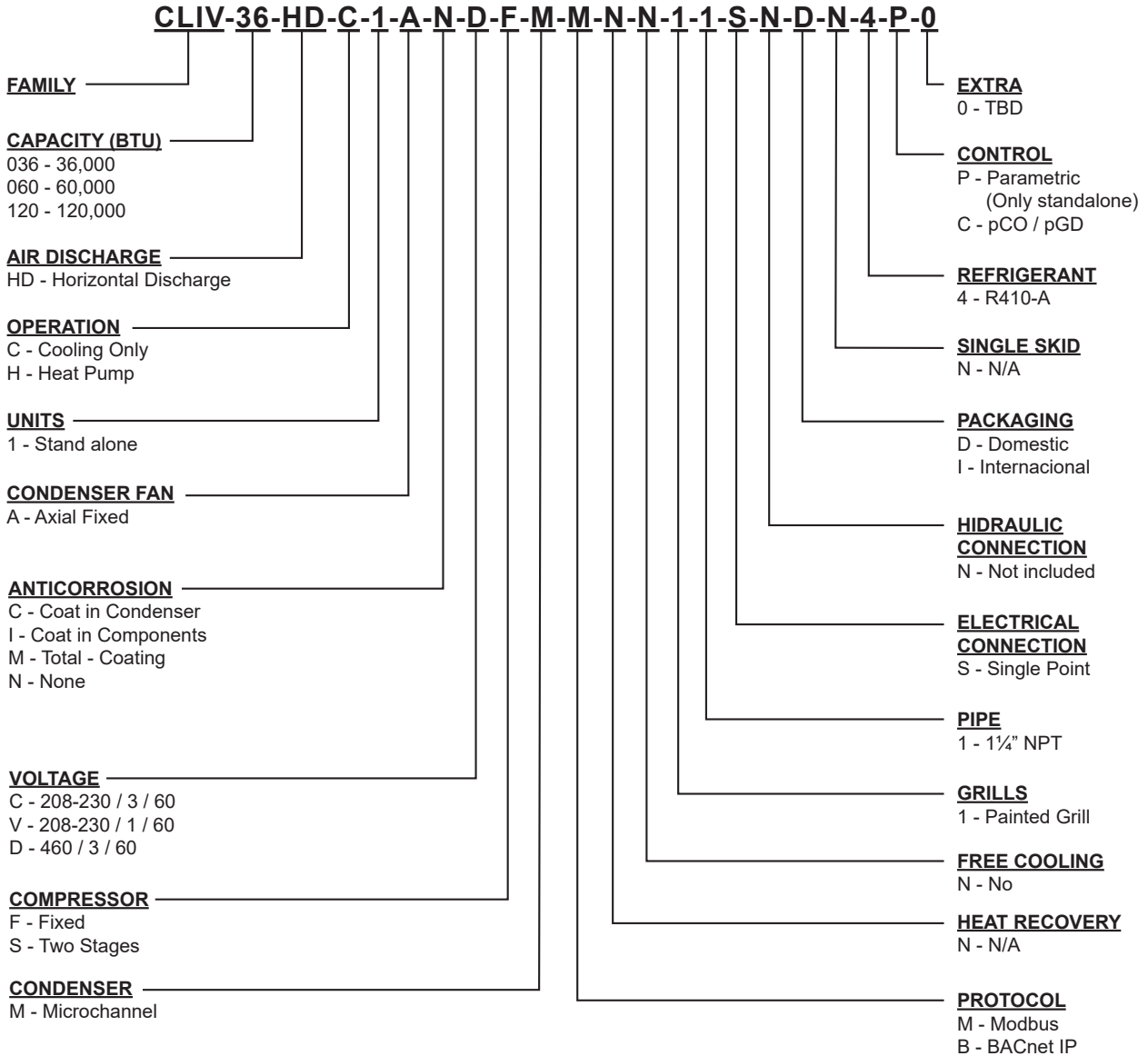

## FEATURES / BENEFITS

---

### EFFICIENCY

Our units are designed to meet the needs of any project. Our intelligent process controllers and smart temperature sensors provide maximum performance and energy savings.

The system automatically modifies the operating mode to maintain optimum system conditions, making it very easy to operate.

All temperature sensors are calibrated and adjusted at the factory prior to shipment. Start-up should be performed by a qualified technician, during initial start-up the unit will be adjusted to local conditions and all operating points will be checked.

Once the unit has been placed in place, operation is a matter of pressing the start/stop button until it is certain that the unit is operating properly, after which the unit will operate automatically, turning itself on according to the demand of the refrigeration system and local conditions.

### FLEXIBILITY

The units are equipped with intelligent processors and sensors that automatically control the temperature at optimum operating conditions.

The units have different capacities ranging from 3 to 10 tons. Capacities vary depending on the number and type of units.

### SAFETY

All structures are made of galvanized sheet steel, coated with electrostatic baked-on paint to ensure long durability and freedom from corrosion under all weather conditions, such as direct sunlight, rain and wind.

All units are designed to fit into a small installation space, thus eliminating large installation areas. We use only high quality components to ensure durability and safety even in harsh environmental conditions.

**NOTE: For applications in tropical climates our units are coated inside and out with corrosion protection (over-ordering).**

Our products have AHRI efficiency certifications and ETL safety certifications, in addition to meeting all industry safety standards. We are members of the American Society of Heating, Refrigerating and Air-Conditioning Engineers (ASHRAE). To show our commitment to our customers and stakeholders; our equipment comes with a 1 year major warranty after start-up.

Our units use R410A refrigerant, which is harmless to the ozone layer and is non-toxic and non-flammable, even in case of leakage.

Finally, the efficiency of the heat exchanger and its modular design allow for quick and easy installation.

### DESIGN

Research conducted by the Engineering Department has resulted in units with high design efficiency and optimum performance. The selection of the main components, our quality and control system guarantee high performance and safety.

All major components are rigorously tested and qualified before installation. Each designed unit has undergone long hours of rigorous testing to ensure the safety, durability and quality of the entire system.

### COMMUNICATION

The units can be controlled in tandem mode and/or can be connected to a central control unit. Operation and user access will be through a 7" color touch screen.

Our units can be managed through different communication protocols; such as Modbus and BACnet, the most commonly used protocols in the Air Conditioning industry.

Our units keep track of all programmable variables in real time, such as performance monitoring, refrigeration cycle specific alarms and electrical system.

The control and monitoring system ensures the correct operation of the unit by monitoring in real time the condition of the major components (high or low refrigerant pressure, compressor and fan motor conditions, etc.).

In case of failure, the event will be recorded for later analysis, facilitating the localization of a possible failure and its solution.

### INSTALLATION

The units have been designed for easy installation. The screw type connections provide easy installation of the water piping. The connections are located on both sides of the unit, so that the piping can be connected to either side of the unit.

The individual assembly of the units reduces the cost of installation, the units have a rigid base that balances the weight of the unit and allows for easy installation.

### MAINTENANCE

The simplicity in the design of each unit allows for maximum ease of maintenance. All major components are available to maintenance personnel by simply opening the service panel.

If an emergency shutdown occurs, the control section will indicate in detail the cause of the failure, helping to facilitate and accelerate troubleshooting.

## TESTING

Each unit is pressure and vacuum tested and then charged with the refrigerant required for proper operation based on the customer's installation conditions.

The units are evaluated at full load operation with water flow, heat load and line voltage placed at actual operating conditions.

**NOTE: The warranty policy requires that commissioning be performed by qualified personnel authorized by the company.**

## INSITUM<sup>®</sup> CORROSION PROTECTION

### *Spray for coating hvac/r products*

Coating is a flexible, water-based, water-reducible, synthetic polymer corrosion coating designed specifically for the protection of HVAC/R coils and components. Insitu<sup>®</sup> Spray Applied Coating contains ES2 (embedded stainless steel pigment) technology, an anti-corrosion coating specifically designed for the protection of coils mounted in corrosive areas.

HVAC/R coils, components and enclosures will have a permanent water-based synthetic coating with ES2 pigment applied to all

areas of the coating surface with no bridging of material between fins. Therefore, ES2 pigments are suitable for even the most corrosive environments and will maintain their appearance after many years of exposure. UV degradation ES2 pigments form a multilayer structure throughout the paint film.

This creates a barrier layer that reflects sunlight away from the paint film preventing UV rays from penetrating. As a result, UV degradation of individual polymer molecules is eliminated, film integrity is maintained and the pigment particles remain well anchored to the substrate.

The resulting smooth, hard finish prevents dirt build-up. The multilayer structure of ES2 pigments delays the passage of water molecules into the film and acts as an effective moisture barrier

### **Ideal applications for Insitu<sup>®</sup> spray-applied coatings.**

- Mini-splits
- Packaged enclosures
- Condensing units
- Modular air handlers
- Air-cooled chillers
- Indoor and outdoor HVAC cabinets and copper tubing
- Heat exchange coils (water, condenser, evaporator, DX)



## TECHNICAL INFORMATION

Figure 1. Air-cooled CLIV 3 RT unit



Selection Conditions	
Head (ft)	0
Condenser water inlet temperature (°F)	95°
Water injection temperature (°F)	44°

Cooling mode	
Rated capacity (BTU/hr)	36,000
Cooling capacity (BTU/hr)	2.80   9.847   33,600
EER (BTU/W*hr)	9.600
IPLV (EER)	7.429

Electrical	
Power supply (V,Hz)	208-230/3/60
MOP (A)	22.15
MCA (A)	14.25
Total amperage (A)	11.40
Total consumption (kW)	3.500

Unit Data	
Refrigerant Type	R-410A (Cargado)
Refrigerant charge (lbs)	6.16
Noise Level (Db)	68.0
Net Weight (lbs)	364
Operating Weight (lbs)	384
Controller	Parametrico (uCH)
Evaporator total pressure drop	16.7 (49.9)
Condenser total pressure drop (ft WG)	0.0330 (0.0986)

Dimensions	
Length (in)	27.7500
Depth (in)	43.5
Height (in)	41.000
Water inlet and outlet diameter (in)	1.2500

Compressor	
Type	Fixed
Quantity	1
Consumption (kW)	2.620
Amperage (A)	8.60

Evaporator	
Type	Stainless steel plates
Water flow (GPM)	6.720 / 4.200
Water inlet temperature (°F)	54°
Water outlet temperature (°F)	44°

Condenser	
Type	Microchannel
Airflow (CFM)	2,400
Area (ft²)	8.96

Fan	
Type	Axial
Pressure drop (in, H2O)	0.400
Air operating range (°F)	55.01/120.0
Consumption (kW)	0.8800
Amperage (A)	2.80

**NOTE: The document is subject to change without notice.**

**NOTE: For more technical information go to the "Software Selection" page.** <http://www.clima-flex.com/chillers/index.php>

### Standard features

- Limited Warranty Comfort Flex units
- 1 year warranty on functional parts of the equipment

## FLOWCON BALANCING VALVE

Flowcon automatic balancing valves are designed to balance heating and air conditioning terminal units by providing a constant flow rate with the added feature of being adjustable.

With these automatic balancing valves, flow can be controlled with two different cartridges: an internal composite cartridge or an externally adjustable E-JUST cartridge. Both types of cartridges maintain constant flow, even when system pressure conditions change.

The E-JUST cartridge can be externally adjusted to one or 41 flow rates even when the system is in operation.

The cartridge is tamper-proof, as the adjustment is made by means of a special flowcon key. In addition, the adjustment can be sealed with a top cap.



### Technical data (valve)

Working Pressure/Temperature:	2500 kPa / -30° C to +100° C
<b>Material</b>	
Cartridge	Polyoxymethylene
Diaphragm	Acrylonitrile-butadiene-rubber hydrogenated or EPDM according to type
Body	ASTM Forged Brass CuZn39Pb2
O-Rings	EPDM
Body Sockets	Female ISO
Flow Range	0.0081 l/s - 1.43 l/s (Standard Compound)
	0.0278 l/s - 1.39 l/s (E-JUST)

**NOTES:** For further information, please consult <http://www.flowcon.com/>

### Valve dimensions

		A/AB DN15/20/25 ABV DN15/20/25				AB DN25/32 ABV DN25/32/40				AB DN40/50
Static Pressure	(kPa)	2500								
	(psi)	360								
Temperature Ranges (average/ambient)	(°C)	-20 to +120 / 0 to +50								
	(°F)	-4 to +248 / +32 to +122								
<b>Pressure drop information</b>		<b>NOTE:</b> For pump hopper calculations, add the minimum pressure differential for the index circuit for pressure losses from other components (i.e. coil valves, etc.).								
Valve Body	(Kv-value)	3.1				12.5				23
	(Cv-value)	3.6				14.5				30.4
<b>Stainless Steel Insert</b>		F3601xx	F3602xx	F3604xx	F3608xx	F3611xx	F3612xx	F3614xx	F3618xx	N/A
Insert Size	(mm)	20	20	20	20	40				
	(inch)	3/4"	3/4"	3/4"	3/4"	1 1/2"	1 1/2"	1 1/2"	1 1/2"	
Pressure	(kPaD)	10 a 95	22 a 210	40 a 390	90 a 880	10 a 95	22 a 210	40 a 390	90 a 880	
Difference	(psid)	1 a 14	2 a 32	4 a 57	8 a 128	1 a 14	2 a 32	4 a 57	8 a 128	
Flow Rate	(l/sec)	0.0210 a 0.315	0.0347 a 0.505	0.0473 a 0.631	0.0694 a 1.01	189.0 a 0.925	0.284 a 1.39	0.379 a 1.85	0.568 a 2.78	
	(GPM)	0.333 a 5.00	0.550 a 8.00	0.750 a 10.0	1.10 a 16.0	3.00 a 14.7	4.50 a 22.0	6.00 a 29.3	9.00 a 44.0	
<b>Standard Composite Insert</b>		ABV1.Y.x grey/red/blue/black/green		ABV1.G.x grey/red/blue/black/green		ABV2.X.x red/white	ABV2.C.x red/white	ABV2.D.x red/white		N/A
Insert Size	(mm)	20		20		40	40	40		
	(inch)	3/4"		3/4"		1 1/2"	1 1/2"	1 1/2"		
Pressure	(kPaD)	15 a 130		30 a 400		15 a 130	22 a 300	30 a 400		
Difference	(psid)	2.2 a 18.9		4.4 a 58		2.2 a 18.9	3.2 a 43.5	4.4 a 58		
Flow Rate	(l/sec)	0.0081 a 0.273		0.0117 a 0.408		0.17 a 0.85	0.23 a 1.21	0.27 a 1.43		
	(GPM)	0.128 a 4.33		0.185 a 6.46		2.69 a 13.5	3.65 a 19.2	4.28 a 22.7		
<b>Inserto E-JUST</b>		E-JUST1.Y.x black/green	E-JUST1.Y.R red	E-JUST1.G.R red	E-JUST1.G.x black/green	E-JUST2.Y.G green				E-JUST3.G.B negro
Insert Size	(mm)	20	20	20	20	40				50
	(inch)	3/4"	3/4"	3/4"	3/4"	1 1/2"				2"
Pressure	(kPaD)	17 a 210	17 a 200	30 a 400	35 a 400	17 a 400				20 a 400
Difference	(psid)	2.5 a 30	2.5 a 29	4.4 a 58	5.1 a 58	2.5 a 58				2.9 a 58
Flow Rate	(l/sec)	0.0278 a 0.169	0.0767 a 0.229	0.113 a 0.352	0.0383 a 0.249	0.149 a 1.62				0.883 a 4.48
	(GPM)	0.44 a 2.68	1.22 a 3.60	1.79 a 5.57	0.67 a 3.95	2.36 a 25.7				14.0 a 70.9



## DESIGN PARAMETERS

Figure 2. Dimensional configuration of the unit cooling only 3-5 RT.

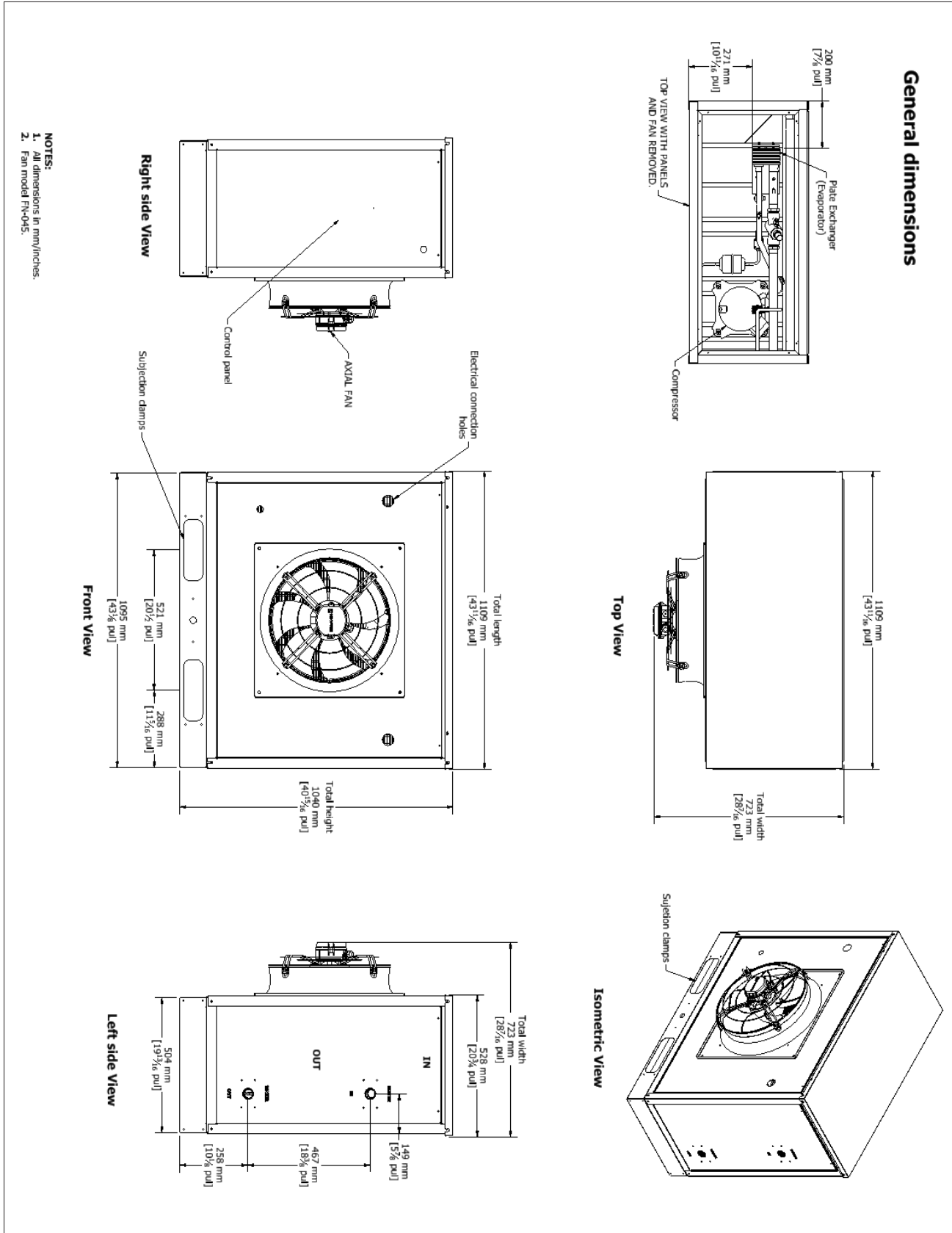
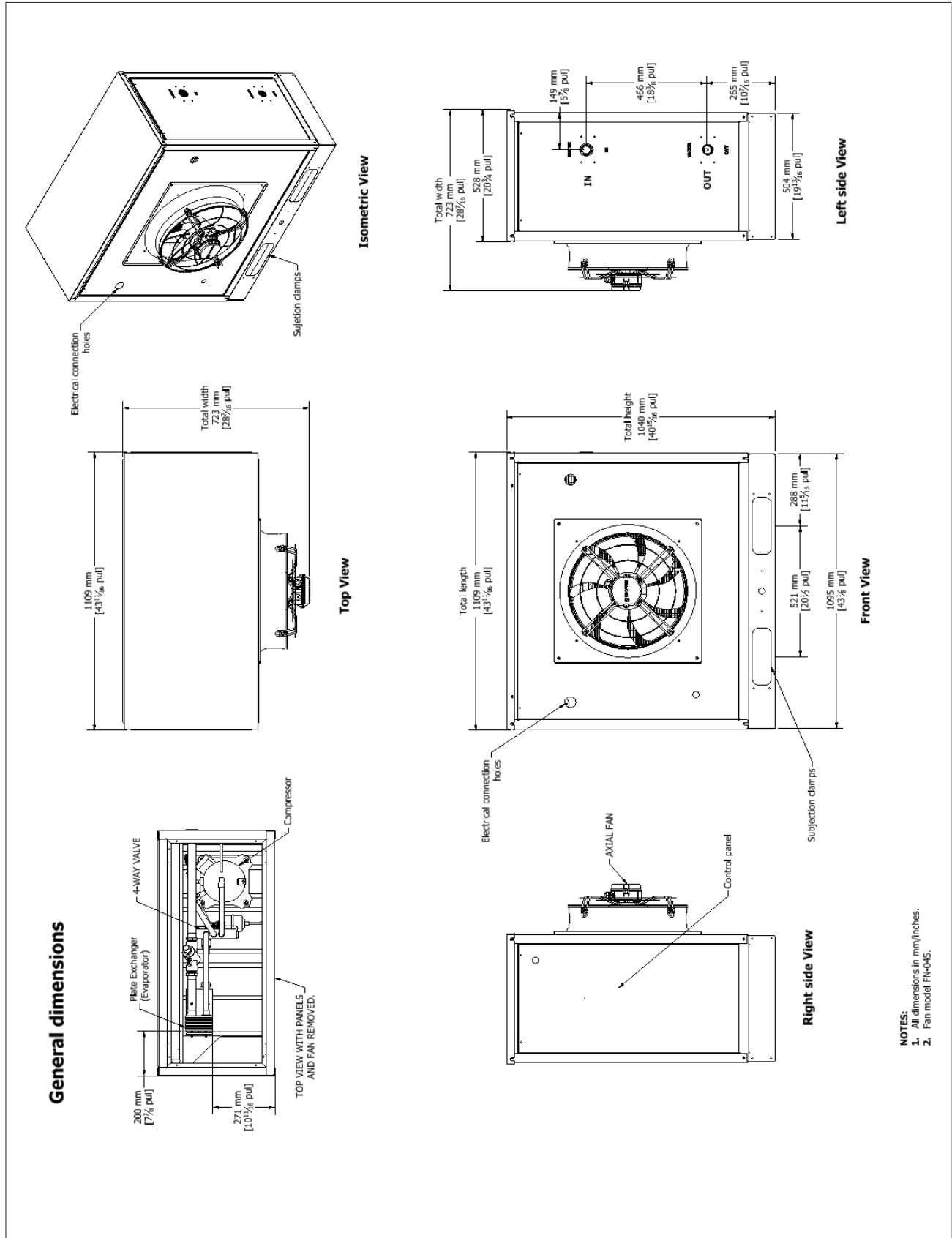
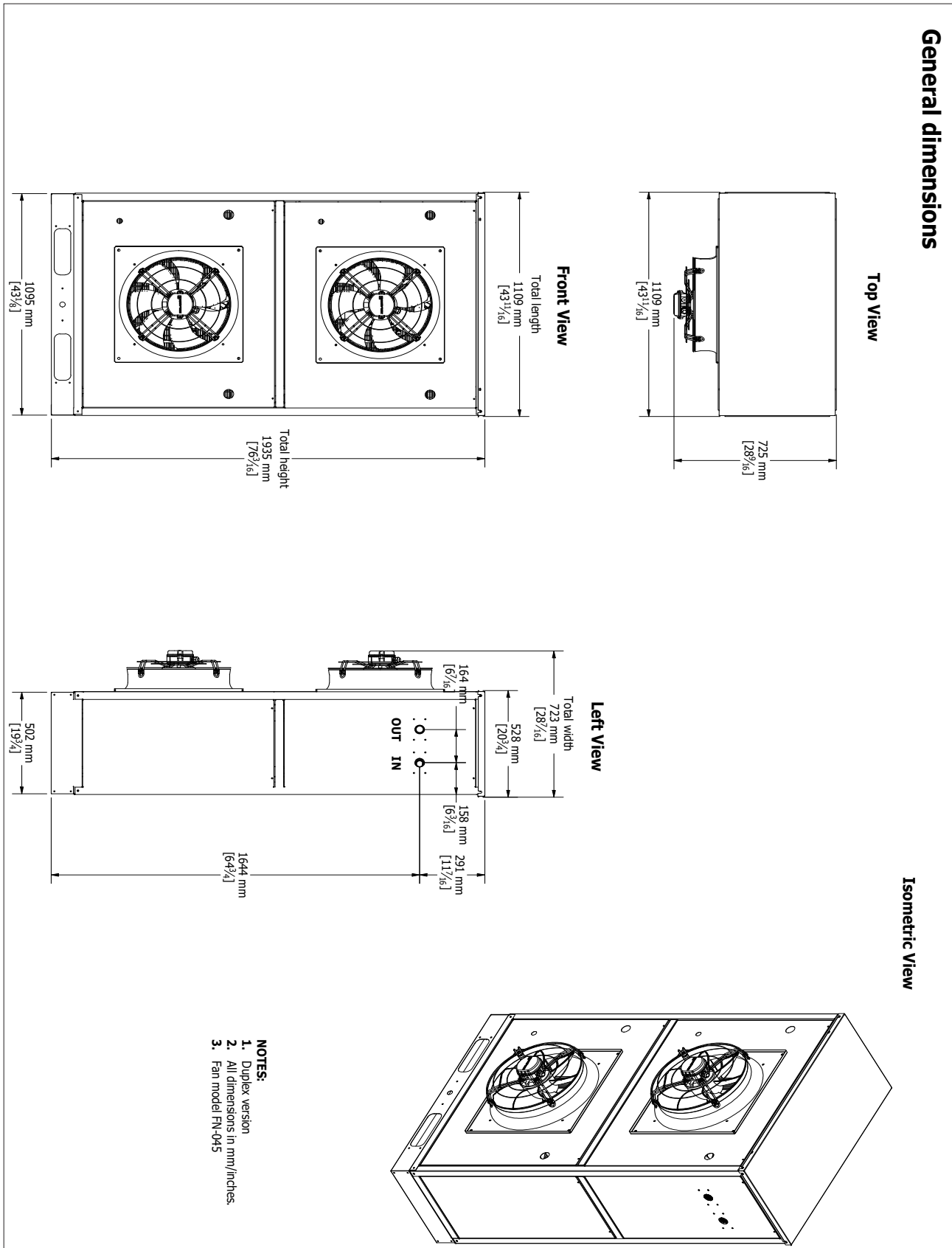

Figure 3. Dimensional configuration of the unit heat pump 3-5 RT.



## DESIGN PARAMETERS

Figure 4. Dimensional configuration of the 10 RT unit.





# ELECTRICAL INFORMATION

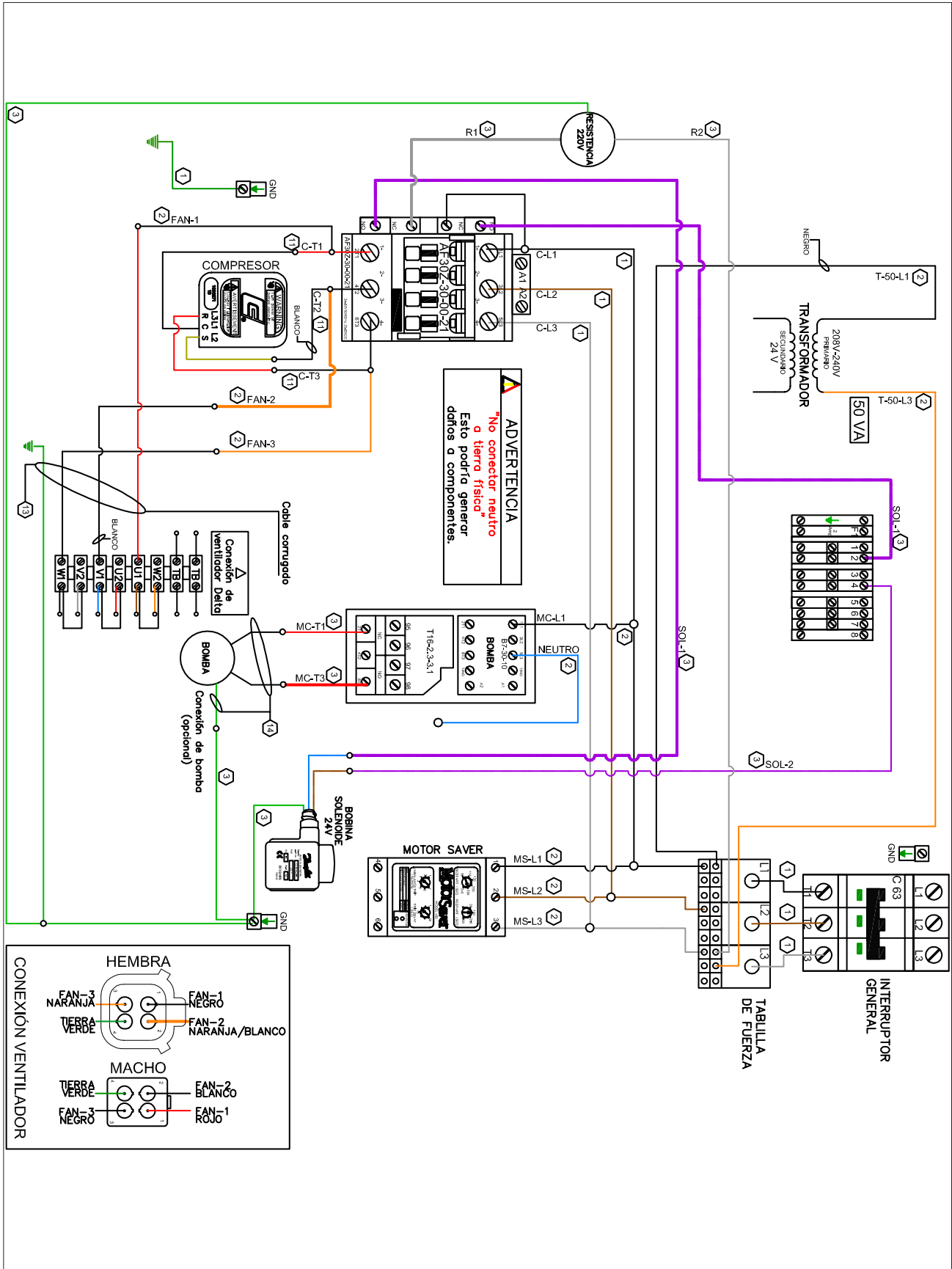
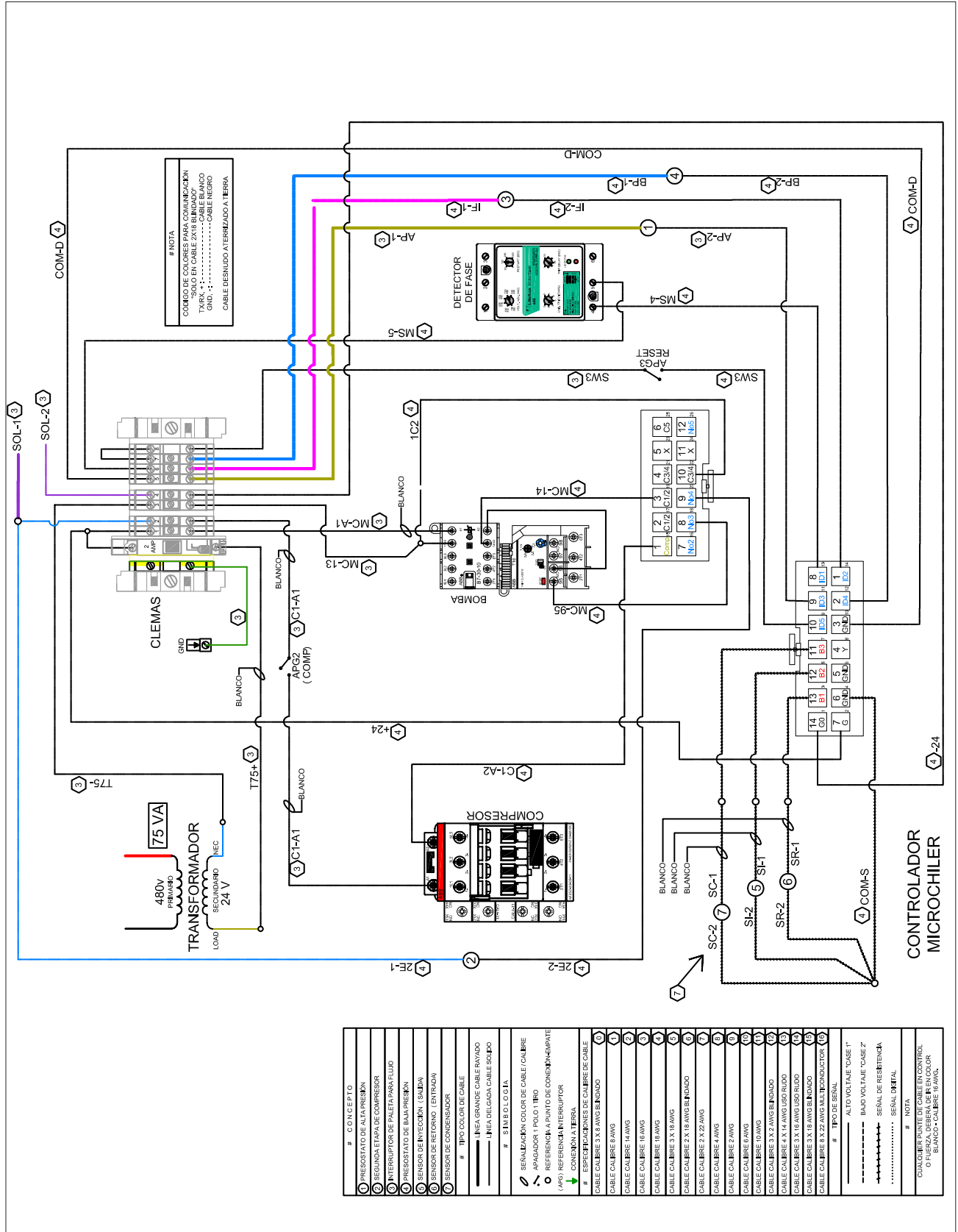

Figure 6. Cooling only diagram (slave 440V)



# ELECTRICAL INFORMATION

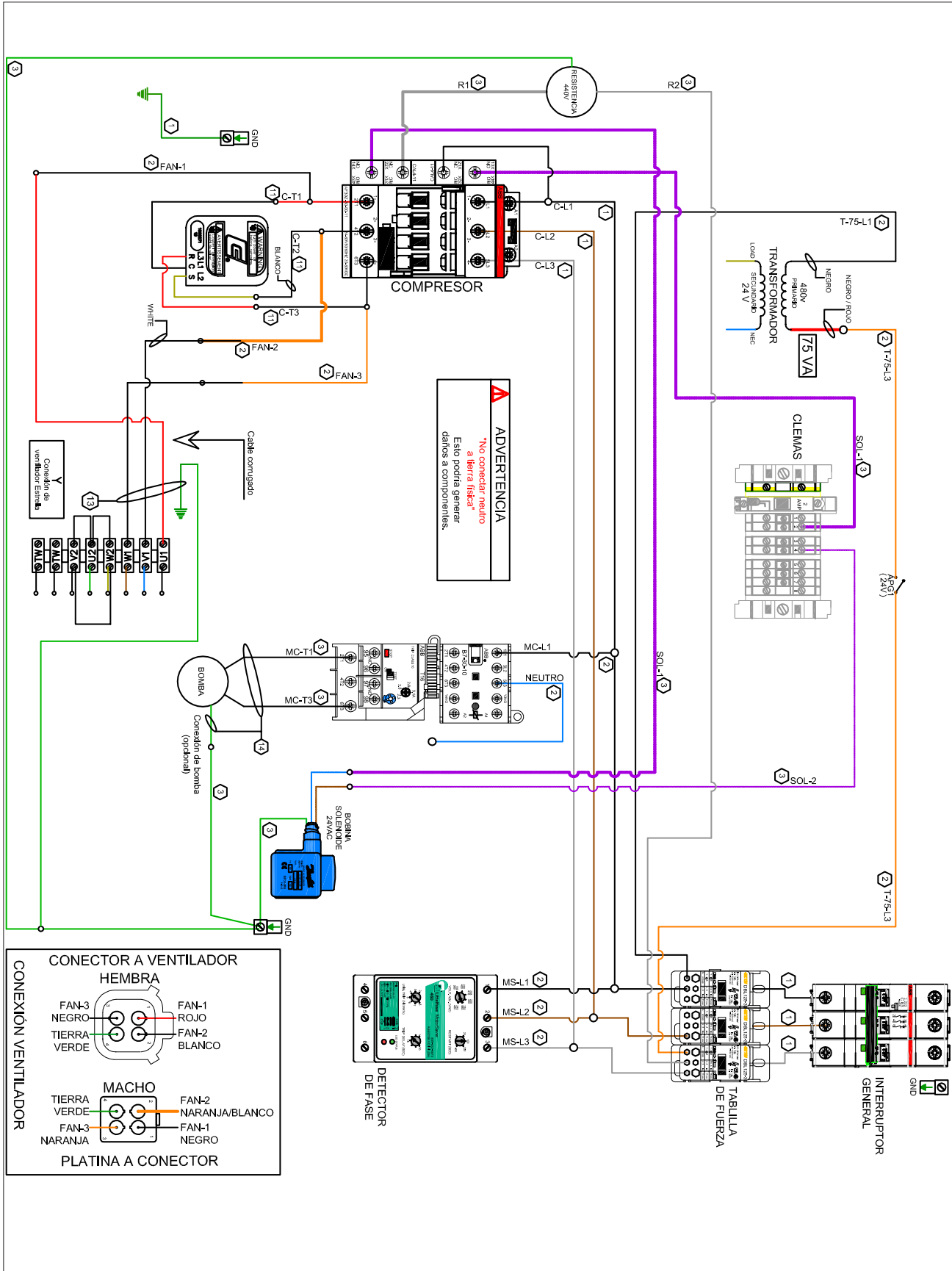
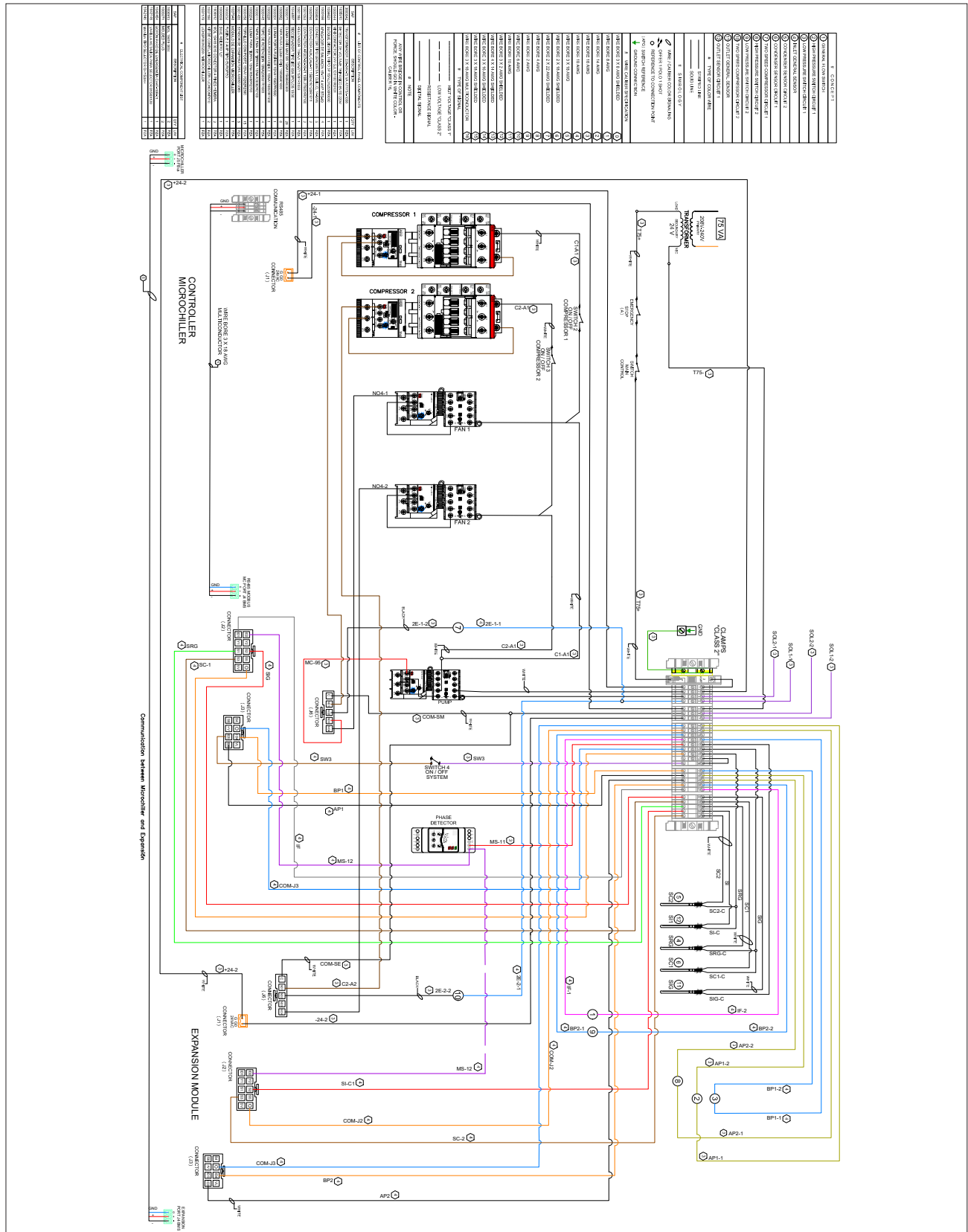
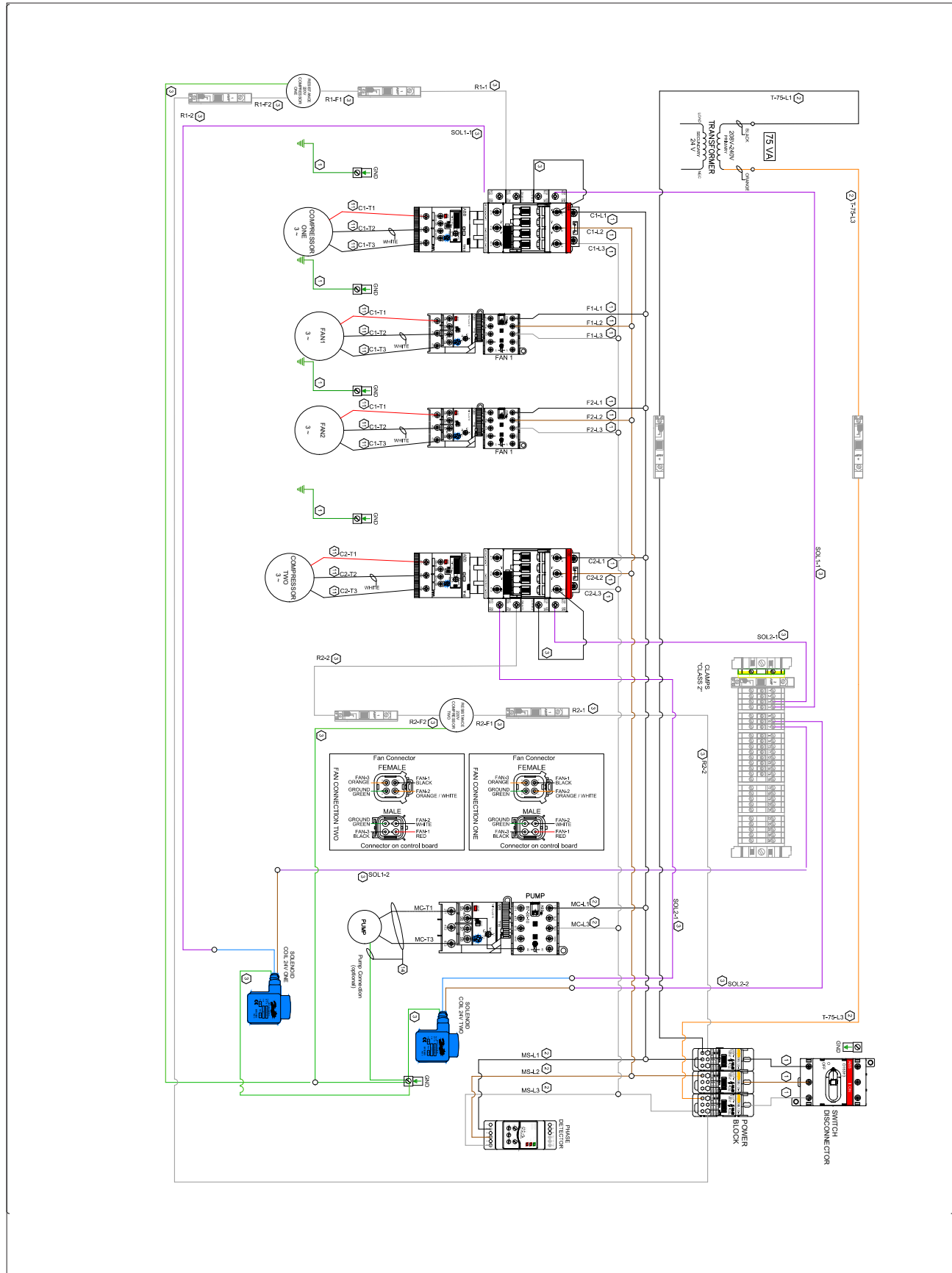

Figure 7. Diagram of cooling only unit 10 RT 220V (Duplex)





# ELECTRICAL INFORMATION



**Table 1. Maximum overcurrent protection and Minimum circuit amperage (220V)**

# EQ	RT/UN	COMPRESSOR	MCA	MOP
1	3	Fix	16.5	29.70
1	5	Fix	23.5	42.30
1	10	Fix	42.3	61.10
1	3	2 Stage	18.0	32.40
1	5	2 Stage	24.1	43.43
1	10	2 Stage	43.4	62.73

**Table 2. Maximum overcurrent protection and Minimum circuit amperage (440V)**

# EQ	RT/UN	COMPRESSOR	MCA	MOP
1	3	Fix	9.0	16.20
1	5	Fix	11.5	20.70
1	10	Fix	20.7	29.90
1	3	2 Stage	8.9	15.98
1	5	2 Stage	10.8	19.35
1	10	2 Stage	19.4	27.95

**THIS PAGE IS INTENTIONALLY LEFT BLANK**

