

Group: Chiller  
Part Number: TDM CLIC STAND ALONE  
Date: 13 July 2023

## **CLIC STAND ALONE Series Air-Cooled Scroll Compressor Chiller Water Generator Unit**

**Model**

**25 TR**

**HFC-410A Refrigerant**

**50/60 Hz**



**SAFETY WARNING.....3**  
**GENERAL DESCRIPTION.....4**  
**FEATURES / BENEFITS.....5**  
**TECHNICAL INFORMATION.....7**  
**DESIGN PARAMETERS.....10**  
**ELECTRICAL INFORMATION.....12**

**Manufactured in an ISO 9001 certified facility**



©2023 Comfort Flex . Illustration and data cover the Comfort Flex product at the time of publication and we reserve the right to make changes in design and construction at any time without notice.

## SAFETY WARNING

This manual provides information on the technical data of the Comfort Flex CLIC STAND ALONE series.

**NOTES:** Installation and maintenance must be performed only by qualified personnel who are familiar with local codes and regulations and who have experience with this type of equipment.

### ⚠ DANGER ⚠

LOCK OUT/LABEL all power sources before starting, pressurizing, depressurizing or shutting down the chiller.

Disconnect electrical power before servicing equipment. More than one disconnection may be required to de-energize the unit. Failure to follow this warning to the letter can result in serious injury or death. Be sure to read and understand the installation, operating and service instructions in this manual.

### ⚠ WARNING ⚠

Electric shock danger. Improper handling of this equipment can cause personal injury or equipment damage. This equipment must be properly grounded. Control panel connections and maintenance should be performed only by personnel knowledgeable in the operation of the equipment being controlled. Disconnect electrical power before servicing equipment. Be sure to install a earth leakage breaker. Failure to install a earth leakage breaker may result in electric shock or fire.

### ⚠ CAUTION ⚠

Static sensitive components. Static discharge during handling of the electronic circuit board can cause damage to components. Use a static strap before performing any service work. Never unplug any cables, circuit board terminal blocks, or power plugs while power is applied to the panel.

### ⚠ CAUTION ⚠

When moving refrigerant to/from the cooler using an auxiliary tank, a grounding strap should be used. An electrical charge builds up when halo-carbon refrigerant travels in a rubber hose. A grounding strap should be used between the auxiliary refrigerant tank and the cooler end sheet (ground to ground), which will safely carry the charge to ground. Failure to follow this procedure may result in damage to sensitive electronic components.

### ⚠ WARNING ⚠

If refrigerant leaks from the unit, there is a potential choking danger as the refrigerant will displace air in the immediate area. Be sure to follow all applicable published industry-related standards and local, state, and federal statutes, regulations, and codes if refrigerant is produced. Avoid exposing refrigerant to an open flame or other ignition source.

### ⚠ WARNING ⚠

Polyolester oil, commonly referred to as POE oil, is a synthetic oil used in many refrigeration systems and may be present in this Comfort Flex product. POE oil, if it ever comes in contact with PCV/CPVC, will coat the inside wall of the PVC/CPVC pipe and cause environmental stress fractures. Although there is no PCV/CPCV pipe in this product, keep this in mind when selecting piping materials for your application, as system failure and property damage could occur. Consult the pipe manufacturer's recommendations to determine appropriate pipe applications.

## DANGER IDENTIFICATION INFORMATION

### ⚠ DANGER ⚠

Danger indicates a dangerous situation which, if not avoided, will result in death or serious injury.

### ⚠ WARNING ⚠

Warning indicates a potentially dangerous situation which may result in property damage, personal injury or death if not avoided

### ⚠ CAUTION ⚠

Caution indicates a potentially dangerous situation which may result in minor injury or equipment damage if not avoided.

**Notes:** Indicate important details or clarifying statements for the information presented.

Our units are built with design and control in mind, so we use specialized technical control software. Some of our special features are our own piping and wiring, Scroll compressors, new generation evaporators, air cooled condensers, optional hydraulic

components, and various safety protections.

Our units are environmentally friendly and operate with R410A refrigerant.

### NOMENCLATURE

#### **CLIC-300-VL-C-1-A-N-D-F-M-M-N-N-0-2-S-N-D-N-4-C-0**

**FAMILY**

**CAPACITY (BTU)**

300 - 300,000

**AIR DISCHARGE**

VL - Vertical Large

**OPERATION**

C - Cooling Only  
H - Heat Pump

**UNITS**

1 - Stand alone  
2 - 2 units  
3 - 3 units  
4 - 4 units  
5 - 5 units  
6 - 6 units  
7 - 7 units  
8 - 8 units  
9 - units  
10 - 10 units

**CONDENSER FAN**

A - Axial Fixed

**ANTICORROSION**

C - Coat in Condenser  
I - Coat in Components  
M - Total Coating  
N - None

**VOLTAGE**

C - 208-230 / 3 / 60  
D - 460 / 3 / 60

**COMPRESSOR**

F - Fixed  
V - Inverter  
T - Tandem

**CONDENSER**

M - Microchannel  
C - Cu-Al

**EXTRA**

0 - TBD

**CONTROL**

P - Parametric  
(Only standalone)  
C - pCO / pGD

**REFRIGERANT**

4 - R410-A

**SINGLE SKID**

O - With base  
N - N/A

**PACKAGING**

D - Domestic  
I - Internacional

**HIDRAULIC CONNECTION**

N - Not included  
Y - Yes included

**ELECTRICAL CONNECTION**

M - Multipoint  
S - Single Point

**PIPE**

6 - 6"

**GRILLS**

1 - Painted Grill  
0 - N/A

**FREE COOLING**

N - No

**HEAT RECOVERY**

N - N/A  
R - Heat recovery

**PROTOCOL**

M - Modbus  
B - BACnet IP

## FEATURES / BENEFITS

### EFFICIENCY

Our units are designed to meet the needs of any project. Our intelligent process controllers and smart temperature sensors provide maximum performance and energy savings.

The system automatically modifies the operating mode to maintain optimum system conditions, making it very easy to operate.

All temperature sensors are calibrated and adjusted at the factory prior to shipment. Start-up should be performed by a qualified technician, during initial start-up the unit will be adjusted to local conditions and all operating points will be checked.

Once the unit has been placed in place, operation is a matter of pressing the start/stop button until it is certain that the unit is operating properly, after which the unit will operate automatically, turning itself on according to the demand of the refrigeration system and local conditions.

### FLEXIBILITY

The units feature intelligent processors and sensors that automatically control the temperature at optimum operating conditions.

The units were designed to be coupled with each other and combined to meet different load variations (Tandem Installation). Up to 10 modules can be combined; these combinations can be made with Water Chiller Units of different capacities ranging from 25 to 250 tons. Capacities vary depending on the number and type of units

### SAFETY

All frames are manufactured from galvanized sheet steel, coated with electrostatic baked-on paint to ensure long durability and freedom from corrosion under all weather conditions, such as direct sunlight, rain and wind.

All units are designed to fit into a small installation space, thus eliminating large installation areas. We use only high quality components to ensure durability and safety even in harsh environmental conditions.

**NOTE: For applications in tropical climates, our units are coated inside and out with corrosion protection (over-ordering).**

Our products have AHRI efficiency certifications and ETL safety certifications, in addition to meeting all industry safety standards. We are members of the American Society of Heating, Refrigerating and Air-Conditioning Engineers (ASHRAE). To show our commitment to our customers and stakeholders; our equipment comes with a 1 year major warranty after start-up.

Our units use R410A refrigerant, which is harmless to the ozone layer and is non-toxic and non-flammable, even in case of leakage.

Finally, the efficiency of the heat exchanger and its modular design allow for quick and easy installation.

### DESIGN

Research conducted by the Engineering Department has resulted in units with high design efficiency and optimum performance. The selection of the main components, our quality and control system guarantee high performance and safety.

All major components are rigorously tested and qualified before installation. Each designed unit has undergone long hours of rigorous testing to ensure the safety, durability and quality of the entire system.

### COMMUNICATION

The units can be controlled in tandem mode and/or can be connected to a central control unit. Operation and user access will be through a 7" color touch screen.

Our units can be managed through different communication protocols; such as Modbus and BACnet, the most commonly used protocols in the Air Conditioning industry.

Our units keep track of all programmable variables in real time, such as performance monitoring, refrigeration cycle specific alarms and electrical system.

The control and monitoring system ensures the correct operation of the unit by monitoring in real time the condition of the major components (high or low refrigerant pressure, compressor and fan motor conditions, etc.).

In case of failure, the event will be recorded for later analysis, facilitating the localization of a possible failure and its solution.

### INSTALLATION

The units have been designed for easy installation. Screw connections provide easy installation of the water piping, which are located on both sides of the unit, so that the piping can be connected to either side of the unit.

The individual assembly of the units reduces installation cost, the units have a rigid base that balances the weight of the unit and allows for easy installation.

### MAINTENANCE

The simplicity in the design of each unit allows for maximum ease of maintenance. All major components are available to maintenance personnel by simply opening the service panel.

If an emergency shutdown occurs, the control section will indicate in detail the cause of the failure, helping to facilitate and accelerate troubleshooting.

## TESTING

Each unit is pressure and vacuum tested and then charged with the refrigerant required for proper operation based on the customer's installation conditions.

The units are evaluated at full load operation with water flow, heat load and line voltage placed at actual operating conditions.

**NOTE: The warranty policy requires that commissioning be performed by qualified personnel authorized by the company.**

## INSITUM<sup>®</sup> CORROSION PROTECTION

### *Spray for coating hvac/r products*

Coating is a flexible, water-based, water-reducible, synthetic polymer corrosion coating designed specifically for the protection of HVAC/R coils and components. Insitu<sup>®</sup> Spray Applied Coating contains ES2 (embedded stainless steel pigment) technology, an anti-corrosion coating specifically designed for the protection of coils mounted in corrosive areas.

HVAC/R coils, components and enclosures will have a permanent water-based synthetic coating with ES2 pigment applied to all areas of the coating surface with no bridging of material between fins. Therefore, ES2 pigments are suitable for even the most corrosive environments and will maintain their appearance after many years of exposure. UV degradation ES2 pigments form a multilayer structure throughout the paint film.

This creates a barrier layer that reflects sunlight away from the paint film preventing UV rays from penetrating. As a result, UV degradation of individual polymer molecules is eliminated, film integrity is maintained and the pigment particles remain well anchored to the substrate.

The resulting smooth, hard finish prevents dirt build-up. The multilayer structure of ES2 pigments delays the passage of water molecules into the film and acts as an effective moisture barrier



### **Ideal applications for Insitu<sup>®</sup> spray-applied coatings.**

- Mini-splits
- Packaged enclosures
- Condensing units
- Modular air handlers
- Air-cooled chillers
- Indoor and outdoor HVAC cabinets and copper tubing
- Heat exchange coils (water, condenser, evaporator, DX)

## TECHNICAL INFORMATION



Selection Conditions	
Head (ft)	0
Condenser water inlet temperature (°F)	95°
Water injection temperature (°F)	44°

Cooling mode	
Rated capacity (BTU/hr)	300,000
Actual capacity (BTU/hr)	285,861
EER (BTU/W*hr)	10.77
IPLV (EER)	9.845

Electrical	
Power supply (V,Hz)	208-230/3/60
MOP (A)	227.25
MCA (A)	126.3
Total amperage (A)	87.04
Total consumption (kW)	26.55

Unit Data	
Refrigerant Type	R-410A (Charged)
Refrigerant charge (lbs)	21
Noise Level (Db)	74
Net Weight (lbs)	1,521
Operating Weight (lbs)	1,671
Controller	Digital (pCO)
Evaporator total pressure drop (ft WG)	16.7 (49.9)
Condenser total pressure drop (ft WG)	0.0330 (0.0986)

### Standard features

- Limited Warranty Comfort Flex units
- 1 year warranty on functional parts of the equipment

Dimensions	
Length (in)	87.25
Depth (in)	32.63
Height (in)	82.75
Water inlet and outlet diameter (in)	6

Compressor	
Type	Fixed
Quantity	1
Consumption (kW)	23.67
Amperage (A)	77.44

Evaporator	
Type	Stainless steel plates
Water flow (GPM)	57.17/35.73
Water inlet temperature (°F)	54°
Water outlet temperature (°F)	44°

Condenser	
Type	Microchannel
Airflow (CFM)	20,000
Area (ft²)	35.84

Fan	
Type	Axial
Pressure drop (in, H2O)	0.400
Air operating range (°F)	55.01/120.0
Consumption (kW)	2.880
Amperage (A)	9.600

**Table 1. Maximum overcurrent protection and minimum circuit amperage (220V)**

# EQ	TR/UN	TR Total	iTotal	MCA	MOP
1	25	25	101	126.3	227.25

**Table 2. Maximum overcurrent protection and minimum circuit amperage (440V)**

# EQ	TR/UN	TR Total	MCA	MOP
1	25	-	62.4	112.28

**Note: The document is subject to change without notice.**

**Note: For more technical information go to the "Software Selection" page. <http://www.comfort-flex.com/chillers/index.php>**

**IFM SENSOR**

- Reliable monitoring of liquid or gaseous fluids in pipelines.
- Numerous possibilities for connection to the process via adapters.
- Simple adjustment of the switching points for fast commissioning.
- Robust stainless steel housing for use in harsh industrial environments.
- LED bar for indication of switching point and flow status.



Product characteristics	
Number of inputs and outputs	Number of digital outputs: 1
Process connection	M18 x 1,5 Internal thread
Application	
Media	Liquids; Gases
Medium temperature [°C]	-25...70
Pressure rating [bar]	300
Liquids	
Medium temperature [°C]	-25...70
Gases	
Medium temperature [°C]	-25...70
Electrical data	
Operating voltage tolerance [%]	-15...15
Operating voltage [V]	< 24 AC / 18...36 DC; (to SELV/PELV)
Current consumption [mA]	< 80
Protection class	III
Power-on delay time [s]	10
Inputs / outputs	
Number of inputs and outputs	Number of digital outputs: 1

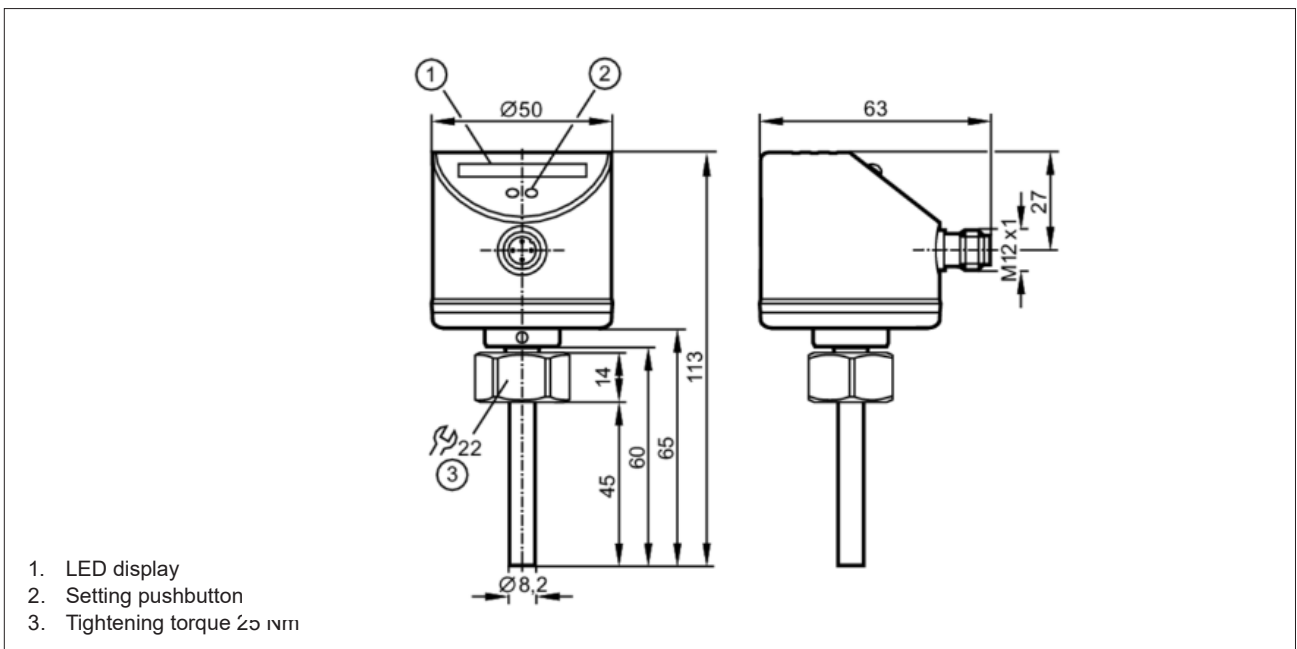



## TECHNICAL INFORMATION

### THERMOSTATIC EXPANSION VALVE 067N3164

- Refrigerants: R410A, R32, R452B, R454B, R22, R134a, R1234ze, R407F, R407A, R404A, R507, R407C and R290
- Capacity range: 3.5 – 52 TR / 12 – 182 kW for R410A
- Balance port design
- Biflow with expansion in both directions
- Low hysteresis
- Long lifetime for heat pump applications
- Mechanical connections types solder ODF, flare, MIO, ORFS are available
- Laser welded, stainless steel power element, capillary tube, and bulb
- MOP (Max. Operating Pressure) function is available
- Optional bleed function
- PS / MWP (maximum working pressure): 49 bar/ 711 psig
- Straightway flow
- Adjustable superheat setting
- UL certified



### Functions

Figure 1. Balanced port design TGE 10

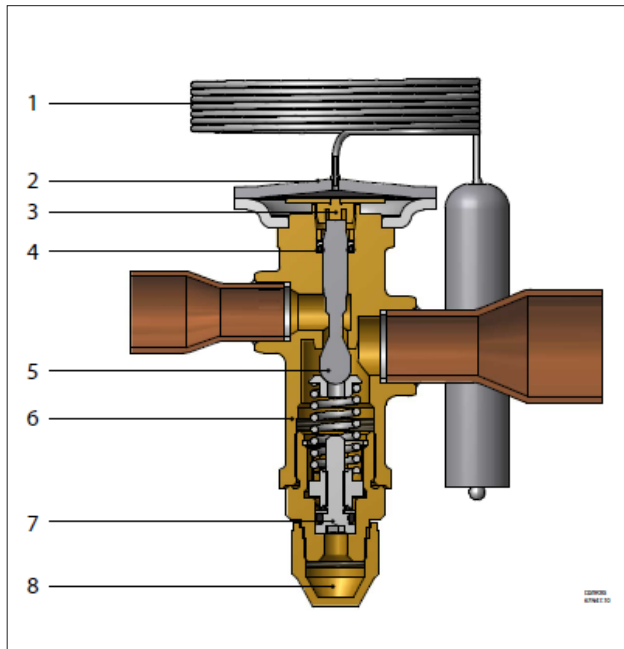

1	Bulb with capillary tube
2	Thermostatic element
3	Thrust pad
4	Push pin seal

Figure 2. Double balanced port design TGE 20 and TGE 40

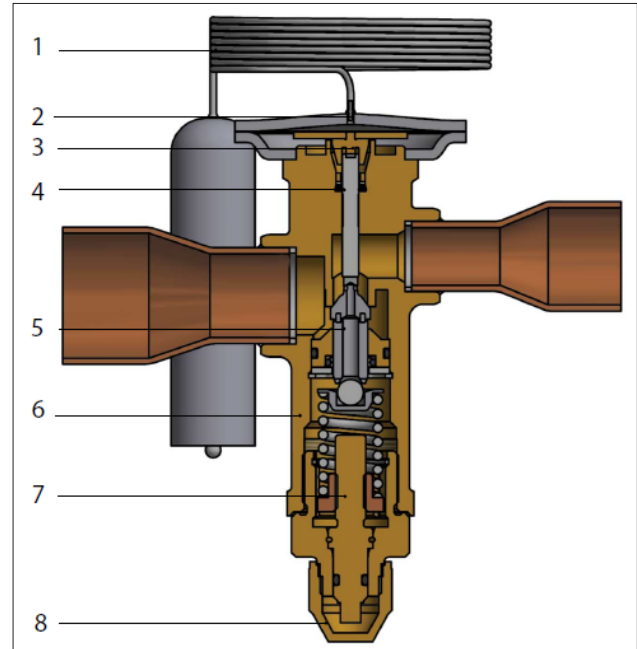

5	Cone
6	Valve body
7	Static SH adjustment spindle
8	Protective cap

### Balanced port design and advantage

Balanced port design prevents changes in pressure drop across the valve from influencing operation and provides excellent control on applications having widely varying operating conditions.

Figure 3. Dimensional configuration (Representative image)

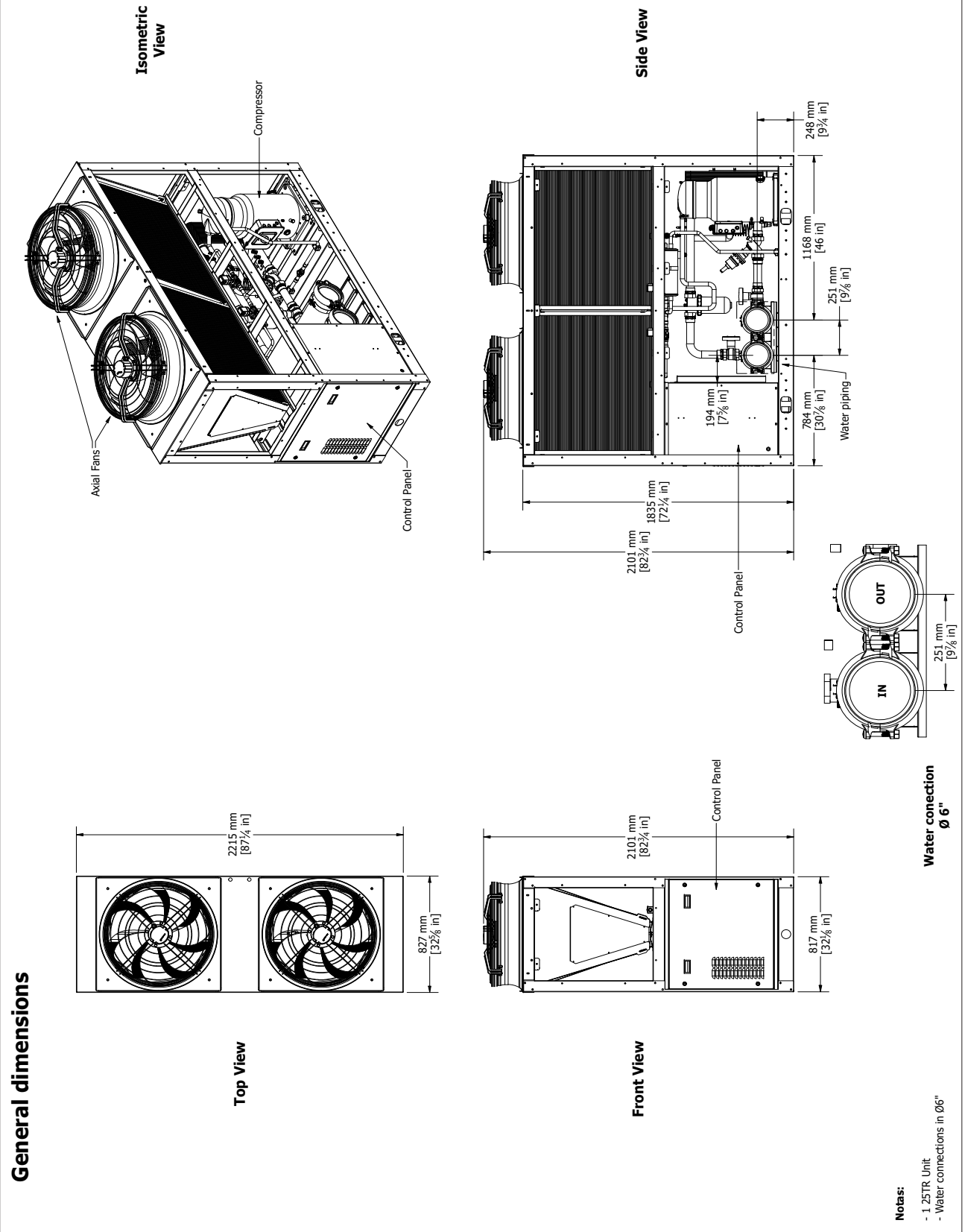

## DESIGN PARAMETERS

Figure 4. Plumbing desing.

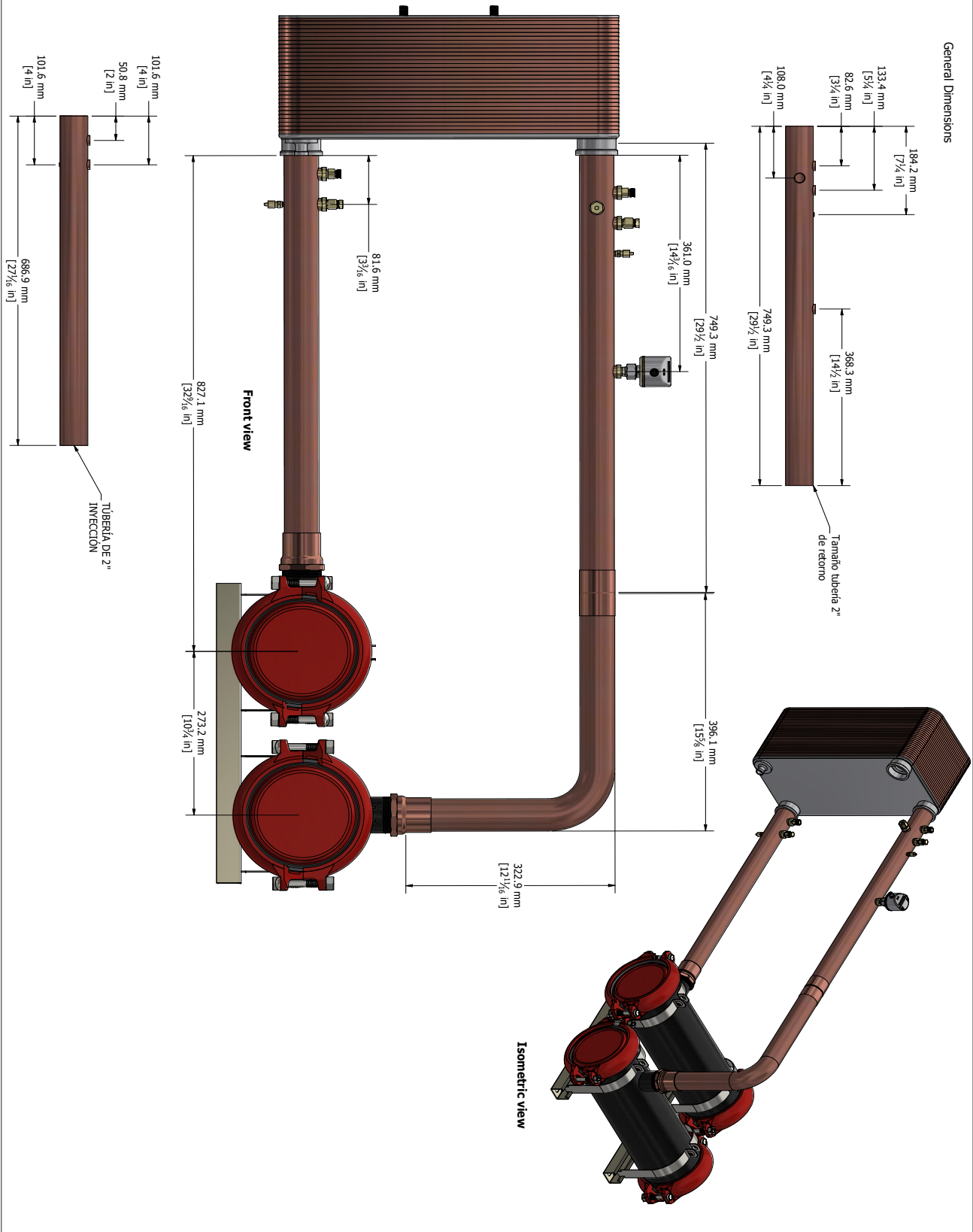

**⚠ WARNING ⚠**

Electric shock danger. Improper handling of this equipment can cause personal injury or equipment damage. This equipment must be properly grounded. Control panel connections and maintenance should be performed only by personnel knowledgeable in the operation of the equipment being controlled. Disconnect electrical power before servicing equipment. Be sure to install a earth leakage breaker. Failure to install a earth leakage breaker may result in electric shock or fire.

Figure 5. Electrical diagram 220V.

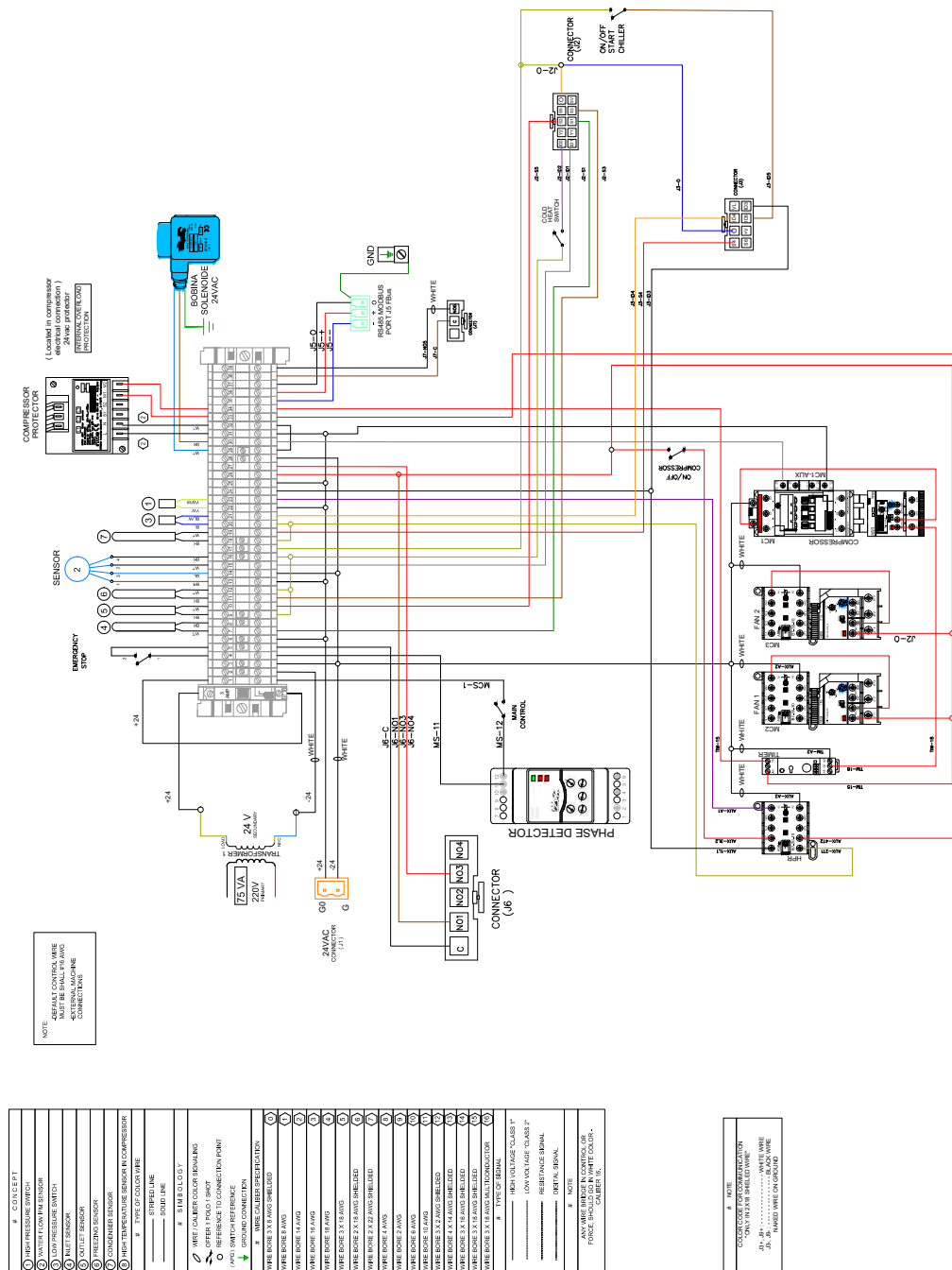

# ELECTRICAL INFORMATION

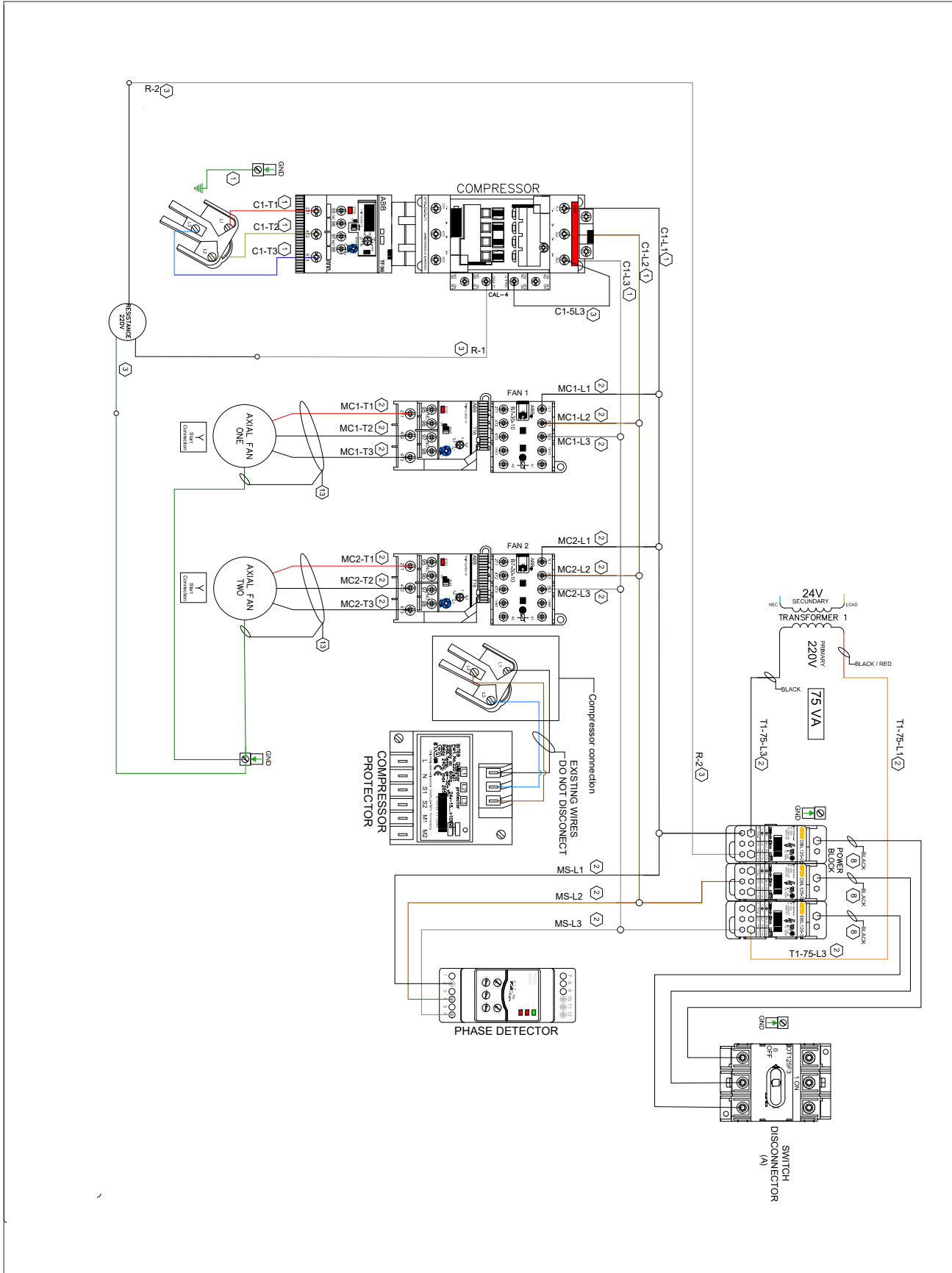
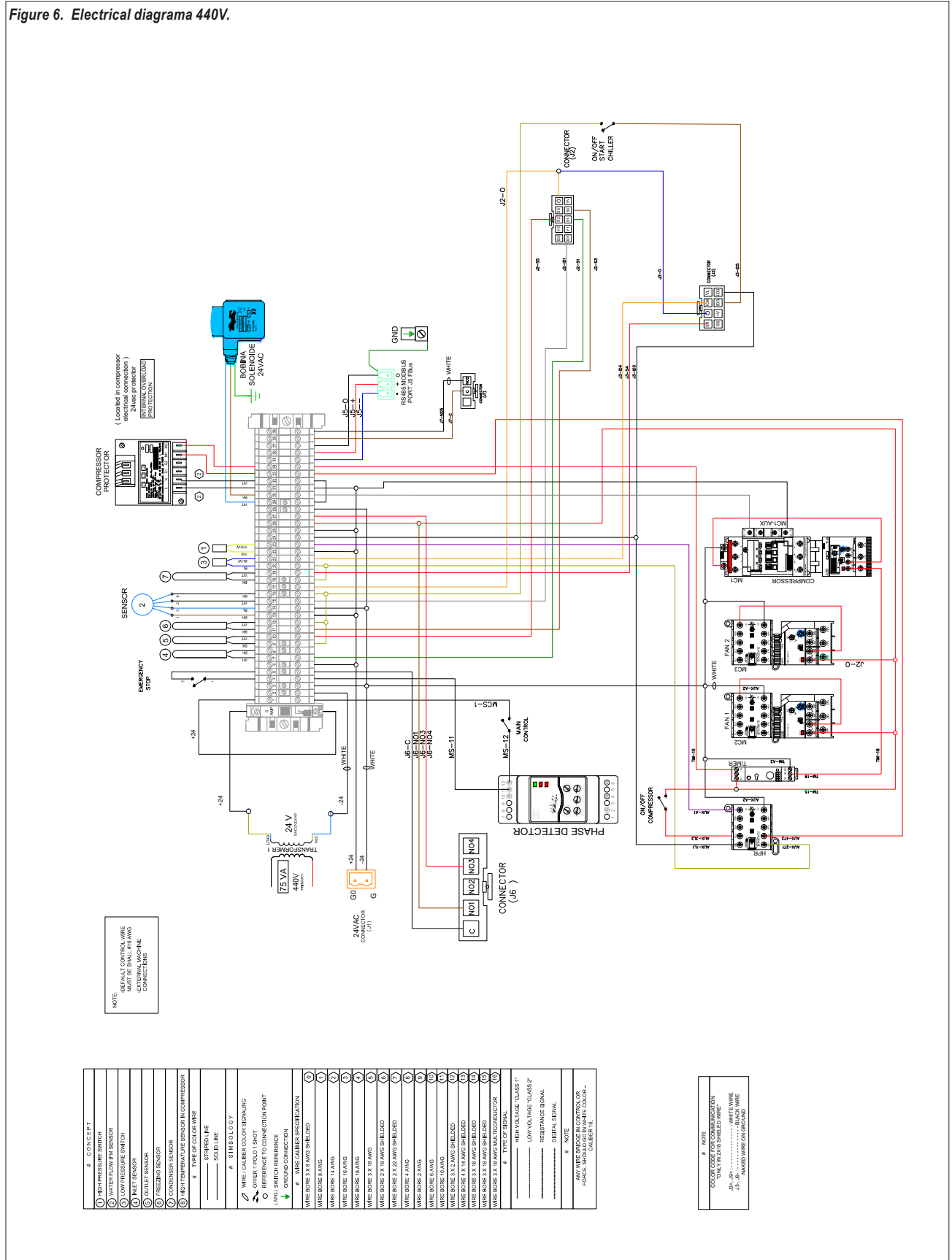

Figure 6. Electrical diagrama 440V.



# ELECTRICAL INFORMATION

