

Installation, Operation and Maintenance Manual

IOM

Group: Chiller
Part Number: IOM CLII
Date: 30 May 2023

CLII Series Water Cooling Unit

Model

30 RT to 300 RT

Refrigerant HFC-410A

50/60 Hz



SAFETY WARNING.....4
GENERAL DESCRIPTION.....5
FEATURES / BENEFITS.....6
INSTALLATION AND APPLICATION INFORMATION.....8
REFRIGERATION SCHEMATICS.....13
DIMENSIONS AND WEIGHTS - PACKAGED UNITS.....14
REFRIGERANT CHARGE.....16
PRESSURE DROP DATA.....18
ELECTRICAL DATA.....19
UNIT CONTROLLER OPERATION.....26
SEQUENCE OF OPERATION35
UNIT FUNCTIONS38
CIRCUIT FUNCTIONS.....39
ALARMS41
CONTROLLER USE.....42
STARTUP AND SHUTDOWN PROCEDURES.....49
UNIT MAINTENANCE.....51
TROUBLESHOOTING CHART.....54

Manufactured in an ISO 9001-certified facility



©2022 Comfort Flex . Illustration and data cover the Comfort Flex product at the time of publication and we reserve the right to make changes in design and construction at any time without notice.

Pre-Start Checklist - Scroll Compressor Chillers

Must be completed, signed, and provided to Comfort Flex at least 2 weeks prior to requested start date.

Job Name				
Installation Location				
Customer Order Number				
Model Number(s)				
G.O. Number(s)				
Chilled Water and Condenser Water for Water-cooled Chiller	Yes	No	N/A	Initials
Piping Complete				
Water strainer(s) installed in piping per manual requirements				
Water System - flushed, filled, and vented; Water treatment in place				
Cooling tower flushed, filled, vented; Water treatment in place (if applicable)				
Pumps installed and operational (rotation checked, strainers cleaned)				
Controls operational (3-way valves, face/bypass dampers, bypass valves, etc.)				
Water system operated and tested; flow meets unit design requirements (Not all units include it)				
Flow switch(es) -installed, wired, and calibrated				
Vent installed on evaporator				
Electrical	Yes	No	N/A	Initials
Building controls operational				
*Power leads connected to power block or optional disconnect				
Power leads have been checked for proper phasing and voltage				
All interlock wiring complete and compliant with unit specifications				
Power applied at least 12 hours before startup				
Oil heaters energized at least 12 hours before startup				
Chiller components (EXV Sensors Transducers) installed and wired properly				
*Wiring complies with National Electrical Code and local codes (See NOTES)				
Miscellaneous	Yes	No	N/A	Initials
Unit control switches all off				
Remote Evaporator / Condenser Piping factory reviewed				
All refrigerant components/piping leak tested, evacuated and charged				
Thermometers, wells, gauges, control, etc., installed				
Minimum system load of 80% capacity available for testing/ adjusting controls				
Document Attached: Technical Breakdown from Selection Software				
Document Attached: Final Order Acknowledgement				
Document Attached: Remote piping approval				
<p>NOTES: The most common problems delaying start-up and affecting unit reliability are:</p> <p>1. Field installed compressor motor power supply leads too small. Questions: Contact the local Comfort Flex sales representative*. State size, number and type of conductors and conduits installed: a. From Power supply to chiller _____ * Refer to NFPA 70-2017, Article 440.35</p> <p>2. Remote Evaporator piping incomplete or incorrect. Provide approved piping diagrams.</p> <p>3. Items on this list incorrectly acknowledged resulting in delayed start and possible extra expenses incurred by return trips.</p>				

Contact Representative

Signed _____
 Name _____
 Company _____
 Date _____
 Phone / Email _____

Comfort Flex Sales Representative

Signed _____
 Name _____
 Company _____
 Date _____
 Phone /Email _____

This manual contains safety instructions that must be followed during installation and maintenance of the unit. Read this manual before installing or operating this unit.

NOTE: Installation and maintenance should be performed only by qualified personnel who are familiar with local codes and regulations and who have experience with this type of equipment.

⚠ DANGER ⚠

LOCK OUT/LABEL all power sources before starting, pressurizing, depressurizing or shutting down the chiller. Disconnect electrical power before servicing equipment. More than one disconnection may be required to deenergize the unit. Failure to follow this warning to the letter can result in serious injury or death. Be sure to read and understand the installation, operating and service instructions in this manual.

⚠ WARNING ⚠

Electric shock danger. Improper handling of this equipment can cause personal injury or equipment damage. This equipment must be properly grounded. Control panel connections and maintenance should be performed only by personnel knowledgeable in the operation of the equipment being controlled. Disconnect electrical power before servicing equipment.

⚠ CAUTION ⚠

Static sensitive components. Static discharge during handling of the electronic circuit board can cause damage to components. Use a static strap before performing any service work. Never unplug any cables, circuit board terminal blocks, or power plugs while power is applied to the panel.

⚠ CAUTION ⚠

When moving refrigerant to/from the cooler using an auxiliary tank, a grounding strap should be used. An electrical charge builds up when halo-carbon refrigerant travels in a rubber hose. A grounding strap should be used between the auxiliary refrigerant tank and the cooler end sheet (ground to ground), which will safely carry the charge to ground. Failure to follow this procedure may result in damage to sensitive electronic components.

⚠ WARNING ⚠

If refrigerant leaks from the unit, there is a potential choking danger as the refrigerant will displace air in the immediate area. Be sure to follow all applicable published industry-related standards and local, state, and federal statutes, regulations, and codes if refrigerant is produced. Avoid exposing refrigerant to an open flame or other ignition source.

⚠ WARNING ⚠

Polyolester oil, commonly referred to as POE oil, is a synthetic oil used in many refrigeration systems and may be present in this Comfort Flex product. POE oil, if it ever comes in contact with PCV/CPVC, will coat the inside wall of the PVC/CPVC pipe and cause environmental stress fractures. Although there is no PCV/CPCV pipe in this product, keep this in mind when selecting piping materials for your application, as system failure and property damage could occur. Consult the pipe manufacturer's recommendations to determine appropriate pipe applications.

DANGER IDENTIFICATION INFORMATION

⚠ DANGER ⚠

Danger indicates a dangerous situation which, if not avoided, will result in death or serious injury.

⚠ WARNING ⚠

Warning indicates a potentially dangerous situation which may result in property damage, personal injury or death if not avoided

⚠ CAUTION ⚠

Caution indicates a potentially dangerous situation which may result in minor injury or equipment damage if not avoided.

NOTES: Indicate important details or clarifying statements for the information presented.

GENERAL DESCRIPTION

Our units are designed to efficiently meet the air conditioning needs of any project. Our units have controls, logic routines and digital sensors that continuously monitor the system to adapt its operation to the level necessary to maintain optimal system

conditions at all times, thus achieving maximum performance and energy savings in a system that is simple to operate and maintain.

NOMENCLATURE

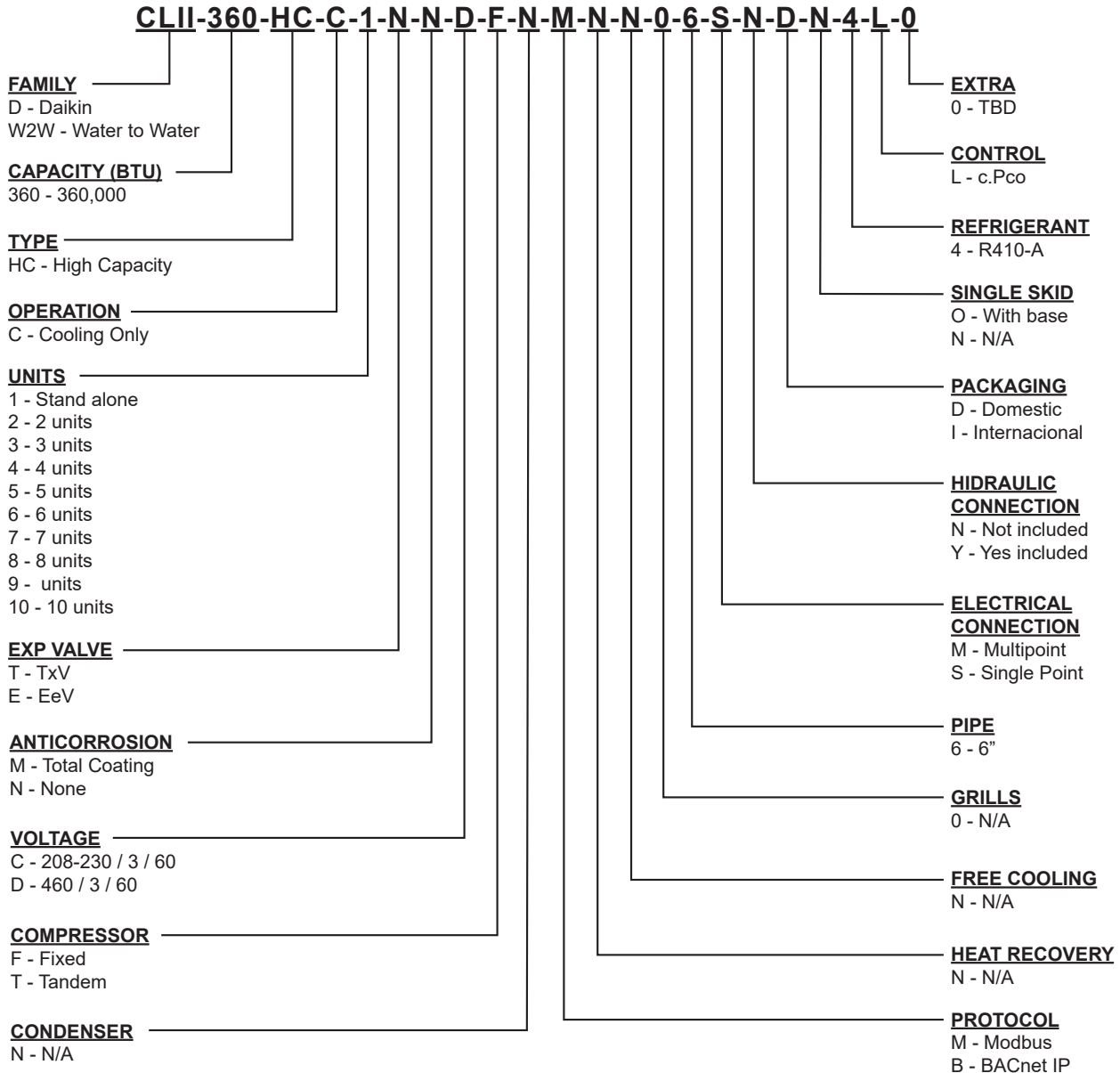

EFFICIENCY

Our units are designed to efficiently meet the air conditioning needs of any project. Our units have controls, logic routines and digital sensors that continuously monitor the system to adapt its operation to the level necessary to maintain optimal system conditions at all times, thus achieving maximum performance and energy savings in a system that is simple to operate and maintain.

All temperature sensors are calibrated and adjusted at the factory prior to shipment.

The start-up of the equipment must be carried out by a qualified technician, during the initial start-up the unit will be adjusted to the local conditions and all operating points will be checked.

Once the unit has been properly installed, the operation is a matter of pressing the digital start and stop button, until making sure that the unit works properly, after this the unit will operate automatically, turning on by itself according to the demand of the system and local conditions.

FLEXIBILITY

Through intelligent processors and digital sensors, our equipment automatically modulates the operation of the system to maintain the water temperature at optimal operating conditions.

Our equipment was designed to be coupled with each other and to be combined to satisfy different load variations (Tandem Installation). Up to 8 modules can be combined in a single installation; these combinations can be made with Water Chiller Units of different capacities ranging from 3 to 30 tons of refrigeration.

The system capacity will then vary depending on the number and type of units installed in it.

SAFETY

The structures of our units are made of galvanized steel sheet, coated with baked electrostatic powder paint (meets the ASTM-B117 1500 hour salt spray test) to ensure long durability and absence of corrosion under any weather conditions, such as direct solar light, rain and wind.

All our units are designed to fit into a reduced installation space, thus eliminating large installation areas. We only use high-quality components to ensure durability and safety, even in harsh environmental conditions.

NOTE: For applications in highly corrosive climates our units can be coated inside and out with extra protection against corrosion. Ask your sales agent for more information.

Our units have AHRI performance and efficiency certifications, and ETL safety certifications, in addition to complying with all industry safety standards.

We are members of the American Society of Air Conditioning, Refrigeration and Heating Engineers (ASHRAE).

To show our commitment to our clients and stakeholders; our equipment has a 1-year warranty after commissioning and start up.

Our units use R410A refrigerant, which is harmless to the ozone layer and the most eco-friendly option possible.

All of our units are designed and manufactured with a focus on safety, performance and quality.

DESIGN

The work carried out by our Engineering and Development department has resulted in equipment with high design efficiency and optimum performance during operation. The selection of high quality main components, our quality processes and the control system during manufacturing, guarantee a high performance and safe unit.

All main components are rigorously tested and validated before being installed. Each designed unit has undergone long hours of rigorous testing to ensure the efficiency, safety, durability and quality of the entire system.

All external paint is baked and meets the strictest quality standards (1500 hour salt spray test ASTM-B117).

The selection of high-end compressors and heat exchangers ensure the capacity and high efficiency of the unit.

Optional water pumps* are specially designed to function properly with minimal vibration and noise.

All our units have a reduced footprint, which facilitates installation and maintenance maneuvers, by being able to use stairs, doors and service elevators to move them.

* Ask your sales rep about factory integrated pump options.

COMMUNICATION

The units can be controlled independently (Individual Mode) or they may be connected to a central control unit (Tandem mode).

The operation and user access will be done through a color touch screen *

Our units can be connected / integrated through different communication protocols; such as TCP / IP, ModBUS and BacNet **, the most common protocols used in the Air Conditioning industry.

Our units keep track of all programmable variables in real time, such as load monitoring in the system, specific alarms of the refrigeration cycle, water cycle and the electrical system. As well as detection of external factors such as fire or flood (optional sensors). The control system ensures the correct operation of the equipment by monitoring in real time the condition of the major components (high or low pressure of the refrigerant and conditions of the compressor, etc.).

In case of failure, the event alarm will be recorded for later analysis, facilitating the location of a possible failure and its solution.

* Depends on the type of control.

** The communication protocols available depend on the type of control.

INSTALLATION

The units have been designed for easy and simple installation. Victaulic type (grooved) fittings provide a simple and safe way to make water the pipe connections. These connections are located on both sides of the equipment, which provides great flexibility for water connections. The individual assembly of the equipment reduces the cost of installation, the units have a rigid base that balances the weight of the unit and allows easy installation.

MAINTENANCE

The simplicity in the design of the unit allows maximum ease when performing preventive / corrective maintenance on them. All major components are available to the maintenance personnel by simply opening the service panels. If an emergency stop occurs, the digital control of the unit will indicate in detail the cause of the alarm, helping to facilitate and speed up its solution.

FEATURES / BENEFITS

TESTING

Before leaving the factory, our units are tested multiple times. Pressure and vacuum tests are performed to detect possible leaks. Once the unit is verified to be leak free, the refrigerant is charged accurately for proper operation based on customer installation conditions.

All units are evaluated and tested at full load operation, with water flow, thermal load and line voltage under the current conditions in which the equipment operates in the field.

NOTE: The warranty policy requires that the commissioning be carried out by qualified personnel authorized by the company.

INSITUM[®] CORROSION PROTECTION

Spray for coating hvac/r products

Coating is a flexible, water-based, water-reducible, synthetic polymer corrosion coating designed specifically for the protection of HVAC/R coils and components. Insitu[®] Spray Applied Coating contains ES2 (embedded stainless steel pigment) technology, an anti-corrosion coating specifically designed for the protection of coils mounted in corrosive areas.

HVAC/R coils, components and enclosures will have a permanent water-based synthetic coating with ES2 pigment applied to all areas of the coating surface with no bridging of material between fins. Therefore, ES2 pigments are suitable for even the most corrosive environments and will maintain their appearance after many years of exposure. UV degradation ES2 pigments form a multilayer structure throughout the paint film.

This creates a barrier layer that reflects sunlight away from the paint film preventing UV rays from penetrating. As a result, UV degradation of individual polymer molecules is eliminated, film integrity is maintained and the pigment particles remain well anchored to the substrate.

The resulting smooth, hard finish prevents dirt build-up. The multilayer structure of ES2 pigments delays the passage of water molecules into the film and acts as an effective moisture barrier.



Ideal applications for Insitu[®] spray-applied coatings.

- Mini-splits
- Packaged enclosures
- Condensing units
- Modular air handlers
- Air-cooled chillers
- Indoor and outdoor HVAC cabinets and copper tubing
- Heat exchange coils (water, condenser, evaporator, DX)

OPERATING AND STANDBY LIMITS

Table 1. Table unit CLII

Unit Size	Mode of Operation	Source EWT		EWT load		Ambient Temperature	
		Min.	Max.	Min.	Max.	Min.	Max.
360	Cooling	50°F (10°C)	104°F (40°C)	53.6°F (12°C)	86°F (30°C)	59	86
	Heating	23°F (-5°C)	86°F (30°C)	59°F (15°C)	122°F (50°C)	59	86

NAMEPLATES

The unit nameplate is located on the outside of the unit power panel. Both the model number and serial number are located on the unit nameplates; the serial number is unique to the unit.

These numbers should be used to identify the unit in case of service, parts or warranty questions. This nameplate also contains the unit's refrigerant charge and electrical ratings. The evaporator nameplate is under the insulation and contains the serial number. The compressor nameplate is located on each compressor and provides pertinent electrical information.

⚠ WARNING ⚠

Installation should be performed by qualified personnel who are familiar with local codes and regulations.

INSPECTION

The equipment must be checked once it has arrived at its installation site for any damage. All components described in the delivery NOTE must be inspected and checked. In case there is evidence of damage, do not remove or repair the damaged components and immediately report the severity and type of damage to the shipping company and your sales representative if possible send photographs that may help explain/detail the damage.

Any damage detected during transport must be reported and documented to the manufacturer prior to repair. Before installing the equipment, check that the model and voltage shown on the nameplate are correct. The manufacturer will not be responsible for any damage once the equipment has been accepted.

HANDLE

When transporting the unit, the use of a forklift or crane is recommended. All units are provided with lifting points. Only these points should be used for lifting the unit as shown in Fig. 1.

⚠ CAUTION ⚠

All lifting locations must be used to avoid damage to the unit.

⚠ DANGER ⚠

Improper rigging, lifting or moving of a unit can result in property damage, serious personal injury or death. Follow the rigging and moving instructions carefully. Do not stand under the unit while it is being lifted or installed.

Figure 1. Required elevation arrangement.

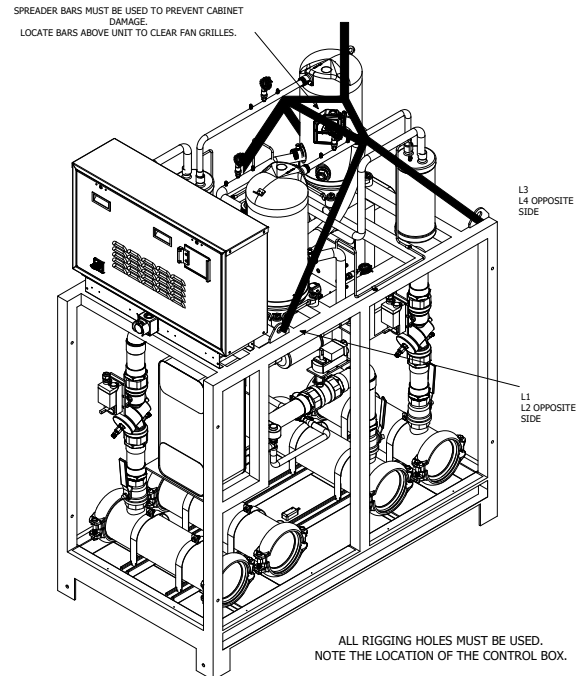

MOUNTING

The CLII series units are designed to be installed INDOORS. It is necessary that the units are installed with sufficient space around them for maintenance purposes (see figure 2).

The equipment must be installed on a solid and well balanced base. In case it is installed on the floor, a solid cement base should be made, which slightly exceeds the area of the equipment. This base must be able to support the weight of the unit.

NOTE: The technical specification sheet of the equipment contains information on dimensions and weights per unit and tandem system.

Anti-vibration mounts must be installed between the frame of the unit and the concrete base of the steel beams; for such installation, use the dimensioning diagram attached in this installation manual. The unit frame must be perfectly level during installation, if necessary insert shims under the anti-vibration mounts. If the unit will be installed in places easily accessible to people and/or animals, it is recommended to place a protection grid to prevent access.

INSTALLATION AND APPLICATION INFORMATION

To ensure optimum performance of the unit once installed, some instructions and precautions should be followed such as:

- Ensure a strong and solid base to reduce noise and vibration.
- Avoid installing the equipment in areas that may be hazardous during equipment maintenance, such as platforms without guardrails, guide rails, or areas that do not meet the space requirements around the unit.
- The installer is responsible for calculating the best position for the unit. It is vitally important that the suggested clearances are respected in order to provide adequate ventilation for the condenser louvers.
- Avoid recirculation of hot air.
- Avoid lack of air supply to the air-cooled condenser. Failure to comply with these conditions can result in increased condenser pressure which in turn can lead to poor energy efficiency and cooling capacity.

CLEANING SERVICE

The correct space dedicated for the maintenance of the equipment will allow a better installation and maintenance, facilitating the access to the service points for the technical personnel. Refer to the drawings shown for unit dimensions. At least one (1) meter is required to service the compressor, allow sufficient space for opening control panel doors. Refer to Figure 2 for minimum clearances. In all cases, these precedents are NOTEd for any need to comply with local regulations.

Figure 2. Cleaning service

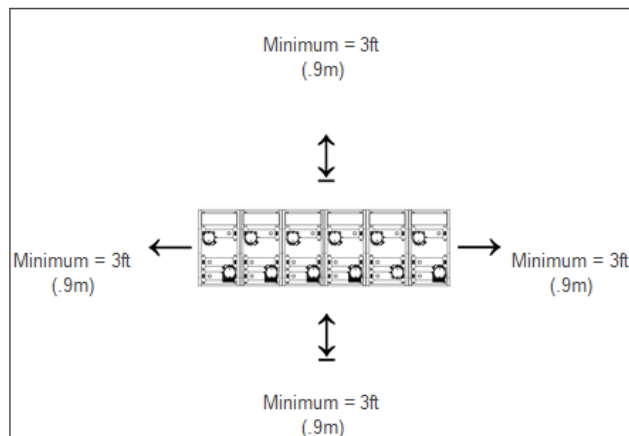

COLD WATER PIPES

⚠ CAUTION ⚠

To prevent damage to the evaporator and possible failure of the chiller, a supply filter is required in the inlet water piping that connects to this evaporator. This filter must be installed prior to operation of the chilled liquid pumps.

Field-installed water piping for the chiller should include:

- A cleanable filter installed at the water inlet to the evaporator to remove debris and impurities before they reach the evaporator. Install the cleanable filter within 1,500 mm tubing length from the evaporator inlet connection and downstream

of any solder connections (no solder connections between the filter and evaporator). CLII models 030-300 require a filter with perforations no larger than 0.063" (1.6 mm) in diameter. For more information, refer to the inlet strainer guidelines (page 12).

- A water flow switch should be installed in the horizontal piping of the supply water line (evaporator outlet) to prevent evaporator freeze-up under low or no flow conditions. The flow switch can be ordered as a factory-installed option, as a field-installed kit, or can be supplied and installed in the field. Piping for units with brazed plate evaporators should have a drain and vent connection at the bottom of the bottom connection piping and at the top of the top connection piping, respectively, (see Figure 7) These evaporators do not have drain or vent connections due to their construction. Purge air from the water system prior to unit start-up to provide adequate flow through the evaporator.
- A suitable support for piping, separate from the unit, to eliminate weight and stress on fittings and connections.
- An expansion tank and regulating valve to maintain water pressure.
- Suitable mechanical connections. All evaporators have.
- OGS type grooved water connections (adhering to AWWA C606) optionally with flanges. PVC piping should not be used.

Figure 3. Typical piping of a welded plate evaporator, series CLII Tandem

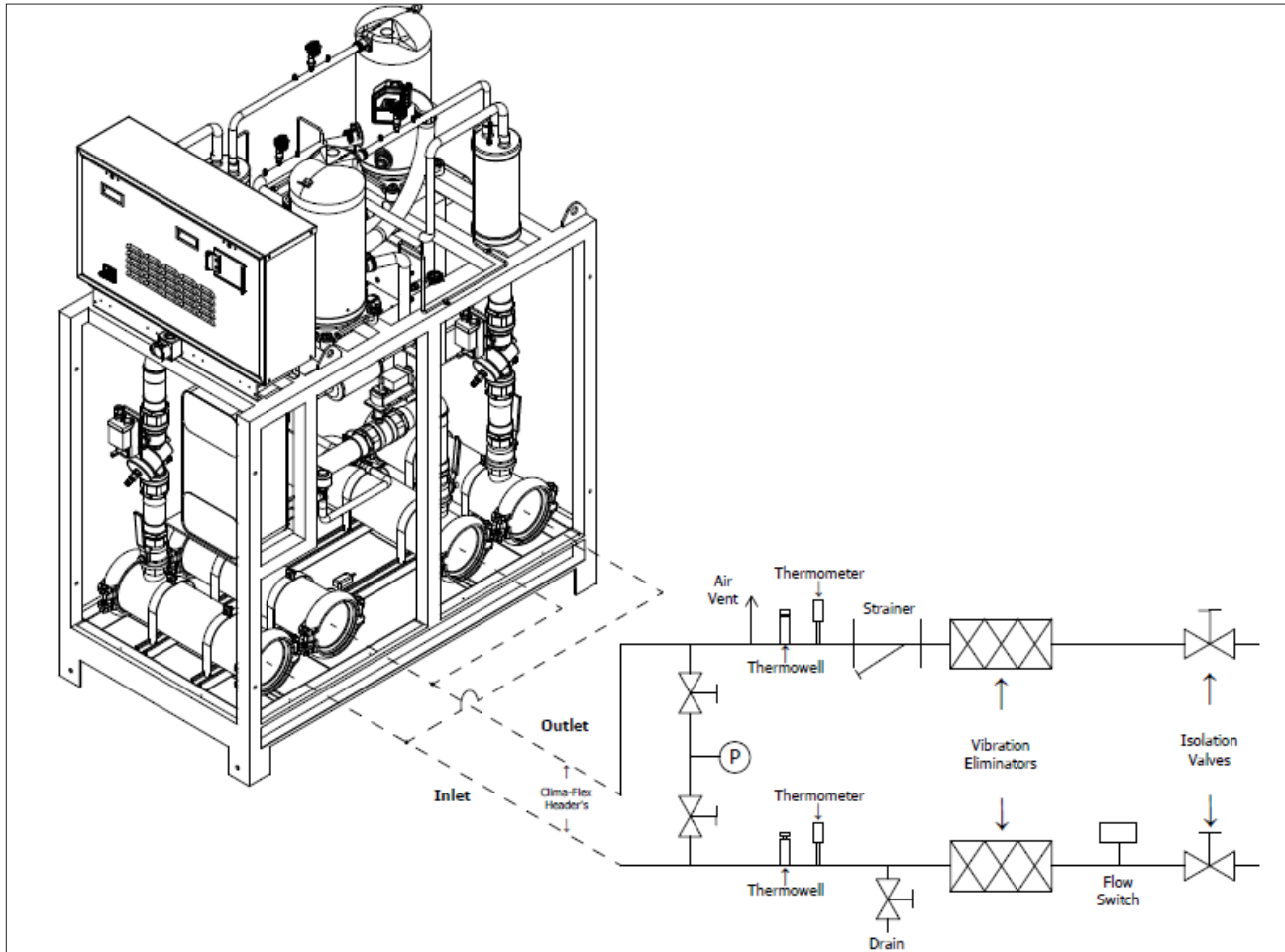

⚠ WARNING ⚠

Polyolester oil, commonly known as POE oil, is a synthetic oil used in many refrigeration systems and is present in this Comfort Flex product. POE oil, if it ever comes in contact with PVC/CPVC, will coat the inside wall of the PVC/CPVC pipe causing environmental stress fractures. Although there is no PVC/CPVC pipe in this product, keep this in mind when selecting piping materials for your application as system failure and property damage could occur. Consult the pipe manufacturer's recommendations to determine suitable pipe applications.

- Shut-off valves to isolate the unit from piping during unit maintenance.
- Minimum bends and elevation changes to minimize pressure drop.
- Vibration eliminators on supply and return water lines to reduce transmissions to the building.
- Thorough flushing of system water piping prior to making connections to the unit evaporator.
- Insulation of the piping, including a vapor barrier, helps prevent condensation and reduces heat loss.
- Periodic water analysis and chemical treatment of the evaporator loop water is recommended immediately after unit start-up.

NOTE: Failure to comply with these measures may result in performance and reliability problems.

INPUT STRAINER GUIDELINES

An inlet water filter kit must be installed in the cold water piping upstream of the evaporator inlet. There are several ways available to meet this requirement:

1. A field supplied strainer that meets the specifications and installation requirements of this manual.

Welded pipe connections between the strainer and evaporator are not allowed due to the possibility of slag entering the evaporator.

It is recommended that the field-installed water piping for the chiller include:

- Temperature sensors at evaporator inlet and outlet connections.
- Water pressure gauge connection taps and pressure gauges on evaporator inlet and outlet connections to measure water pressure drop.

INSTALLATION AND APPLICATION INFORMATION

TECHNICAL DATA OF THE STRAINER

- **Head and neck nut:** Brass
- **Filter element:** Polyamide body coated with nylon mesh
- **Filter cup:** Trogamid T 5000 (virtually impact resistant, pressure wave resistant, permanently transparent, stress resistant).
- **(Brass cup available on request).**
- **Working pressure:** PN 16
- **Test pressure:** 25 bar
- **Maximum water temperature:** 30° C
- **Mesh size:** 95-140 µm.
- **Available with and without Rp 1/8/8 pressure gauges.**

Table 2. Flow rates according to DVGW test

DN 20	Rp 3/4	5,0 m3/h	Δp = 0,2 bar:
DN 35	Rp 1	7,9 m3/h	
DN 32	Rp 1 1/4	12,0 m3/h	
DN 40	Rp 1 1/2	11,9 m3/h	
DN 50	Rp 2	14,9 m3/h	

Figure 4. Factory installed strainer

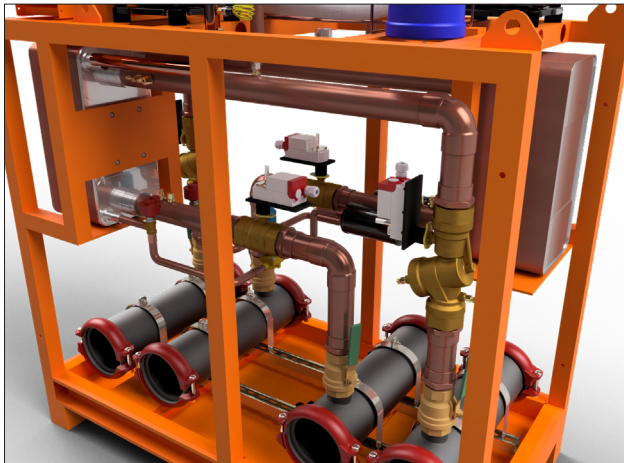

WATER FLOW LIMITATIONS

Constant evaporator flow

Maximum flow rate and pressure drop are based on a 6°F temperature drop. Flow rates above the maximum values will result in unacceptable pressure drops and may cause excessive erosion, which could lead to failure.

The minimum flow rate and pressure drop are based on a full load evaporator temperature drop of 16°F. Evaporator flow rates below the minimum values may result in laminar flow leading to low pressure alarms, fouling and poor temperature control (See pressure drop on page 20).

Variable evaporator flow

Reducing evaporator flow rate in proportion to load can reduce system energy consumption. The rate of flow change should be a maximum of 10 percent of the flow per minute.

For example, if the maximum design flow rate is 200 gpm and is to

be reduced to a flow rate of 140 gpm, the flow change is 60 gpm. Ten percent of 200 gpm equals a change of 20 gpm per minute, or a minimum of three minutes to go from the maximum flow to the desired flow.

If the flow rate falls below the minimum allowable, large reductions in heat transfer can occur. If the flow rate exceeds the maximum, excessive pressure drop and tube erosion can occur.

System water considerations

All chilled water systems need adequate time to recognize a load change, respond to the change and stabilize to avoid undesirable compressor short cycling or loss of temperature control.

In air conditioning systems, the potential for short cycling often occurs when the building load drops below the minimum capacity of the chiller plant or in tightly coupled systems with very small water volumes. Some of the aspects that the designer should consider when studying water volume are the minimum cooling load, the minimum capacity of the chiller plant during the low-load period, and the desired cycle time for the compressors. Assuming there are no sudden loads and the chiller plant has a reasonable drawdown, the rule of thumb of "water volume in gallons equals two to three times the chilled water flow rate in gpm" is often used. A storage tank may have to be added to the system to achieve the recommended volume.

The quality of water supplied by the owner/occupant/operator/user to a cooling system should minimize corrosion, scale buildup, erosion, and biological growth to achieve optimum efficiency of HVAC equipment without creating a hazard to operating personnel or the environment. Filters should be used to protect cooling systems from waterborne debris. Comfort Flex is not responsible for damage caused by waterborne debris or damage to chiller heat exchangers due to improper water treatment.

Water systems must be cleaned and flushed prior to chiller installation. Testing and water treatment should be verified during initial chiller installation/commissioning and should be maintained on an ongoing basis by water treatment professionals

⚠ CAUTION ⚠

Improper use of detergents, chemicals and additives in the cooling system water can adversely affect the performance of the chiller and potentially result in repair costs not covered under warranty. Any decision to use these products is at the discretion of the owner/occupant/operator/user, and the owner/occupant/operator/user assumes full responsibility for any damage that may occur due to their use.

COLD WATER PUMP

It is important that the chilled water pumps are connected to and controlled by the chiller's microprocessor. The controller will activate the pump whenever at least one chiller circuit is enabled for operation.

This helps ensure proper start-up sequence of the unit. The pump will also turn on when the water temperature is below the freeze set point for longer than the specified time to help prevent evaporator freeze-up. Connection points are shown in the field wiring diagram starting on page 20+.

⚠ CAUTION ⚠

Adding glycol or draining the system is the recommended method of freeze protection. If the chiller does not have the ability to control the pumps and the water system is not drained or does not have adequate glycol at subfreezing temperatures, catastrophic evaporator failure can occur.

If the chiller is not allowed to control the pump, the following problems may occur:

1. If the chiller attempts to start without first starting the pump, the chiller will lock out with the no flow alarm and require a manual restart.
2. If the chiller evaporator water temperature drops below the “freezing set point”, the chiller will attempt to start the water pumps to prevent the evaporator from freezing.
3. If the chiller does not have the ability to start the pumps, the chiller will alarm for lack of water flow.
4. If the chiller does not have the ability to control the pumps and the water system must not be drained in freezing temperatures or contain glycol, the chiller may be subject to catastrophic evaporator failure due to freezing.

FLOW SWITCH

All chillers require a chilled water flow switch to verify that there is adequate water flow through the evaporator and to shut down the unit if necessary to prevent evaporator freeze-up under low or no flow conditions.

A factory-installed thermal dispersion flow switch will be installed on packaged models. On remote evaporator models, the flow switch can be supplied separately in the field, or optionally shipped loose for field installation. Terminals for field mounting and wiring of the water flow switch are provided in the unit control center.

Wire from the Y and R terminals on the switch to the terminals on the unit control panel shown in the field wiring diagrams, page 20 through page 25. Mount the flow switch on the outlet water line to shut off the unit when water flow is interrupted. A flow switch is an equipment protection control and should never be used to cycle the unit.

Installation should be in accordance with the manufacturer’s instructions included with the switch. Flow switches should be calibrated to shut the unit off when operating below the minimum flow rate. There is also a set of paddle switch contacts on the switch that can be used for an indicator light or alarm to indicate when a “no flow” condition exists. Protect any flow switch that is installed outdoors from freezing. It is not recommended that differential pressure switches be installed outdoors. They may freeze and not indicate a no-flow condition.

GLYCOL SOLUTIONS

The use of glycol can affect system performance depending on its concentration and should be taken into account during initial system design. When glycol is added to the chilled water system to protect against freezing, it should be NOTE that the refrigerant suction pressure will be lower, the cooling performance will be lower and the water side pressure drop will be higher. The reduction in performance depends on the glycol concentration and temperature.

Test the coolant with a clean and accurate glycol refractometer to determine the freezing point.

⚠ CAUTION ⚠

The installed glycol level must match the nominal glycol percentage indicated on the submitted chiller technical data sheet. Failure to meet the nominal glycol percentage may result in damage to the unit and loss of unit warranty.

⚠ CAUTION ⚠

Do not use automotive grade antifreeze. Industrial grade glycols should be used. Automotive antifreeze contains inhibitors that will cause plaque formation on the cooler evaporator copper tubes. The type and handling of the glycol used should be consistent with local codes.

REFRIGERATION SCHEMATICS

Figure 5. CLII Cooling Schematics

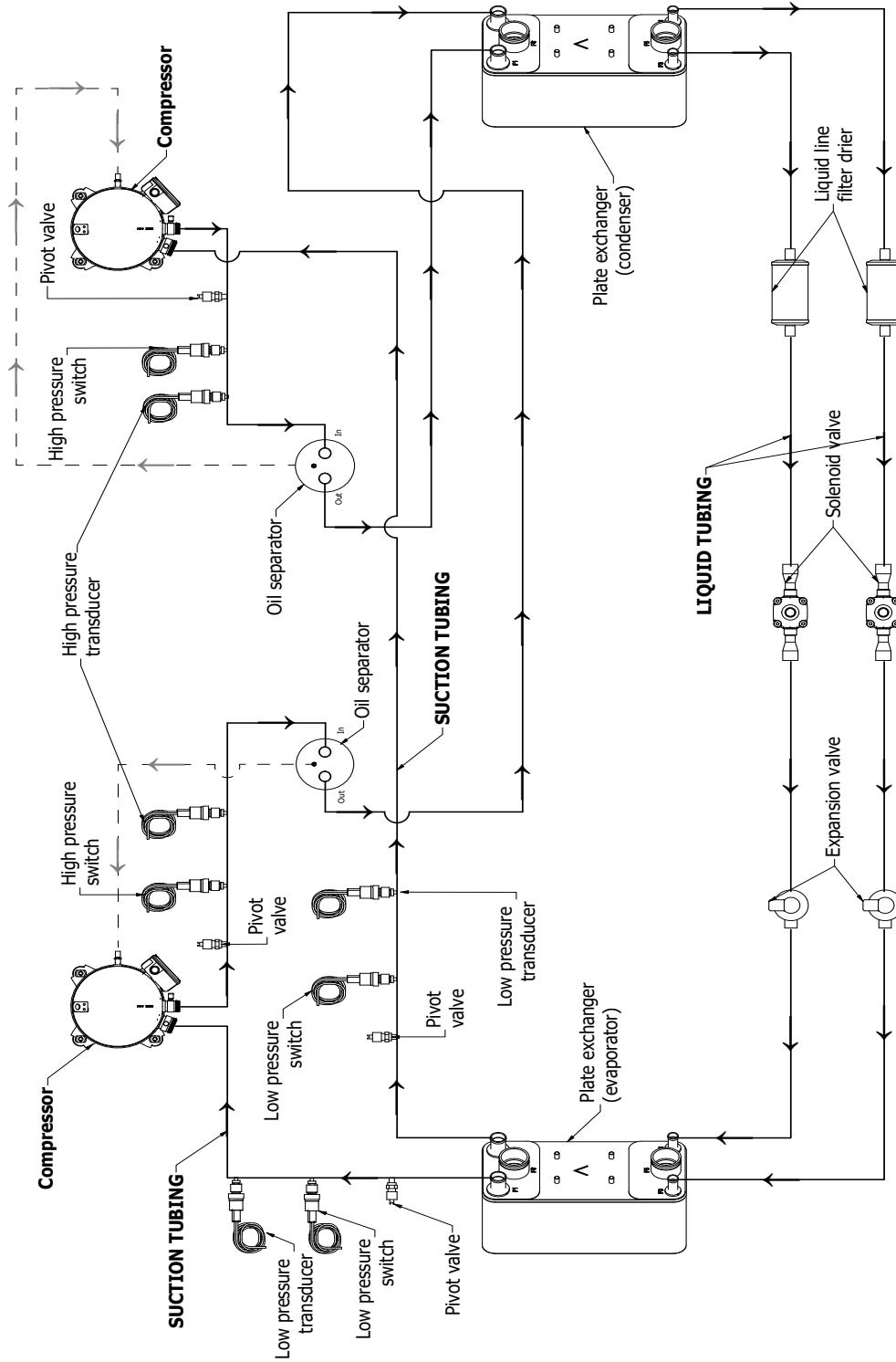

Notes:

- Oil separator.
- Two refrigeration circuits.
- Two hydraulic circuit.
- Two plate exchanger (evaporator/condenser).
- Electronic expansion.

Figure 6. CLII

General dimensions

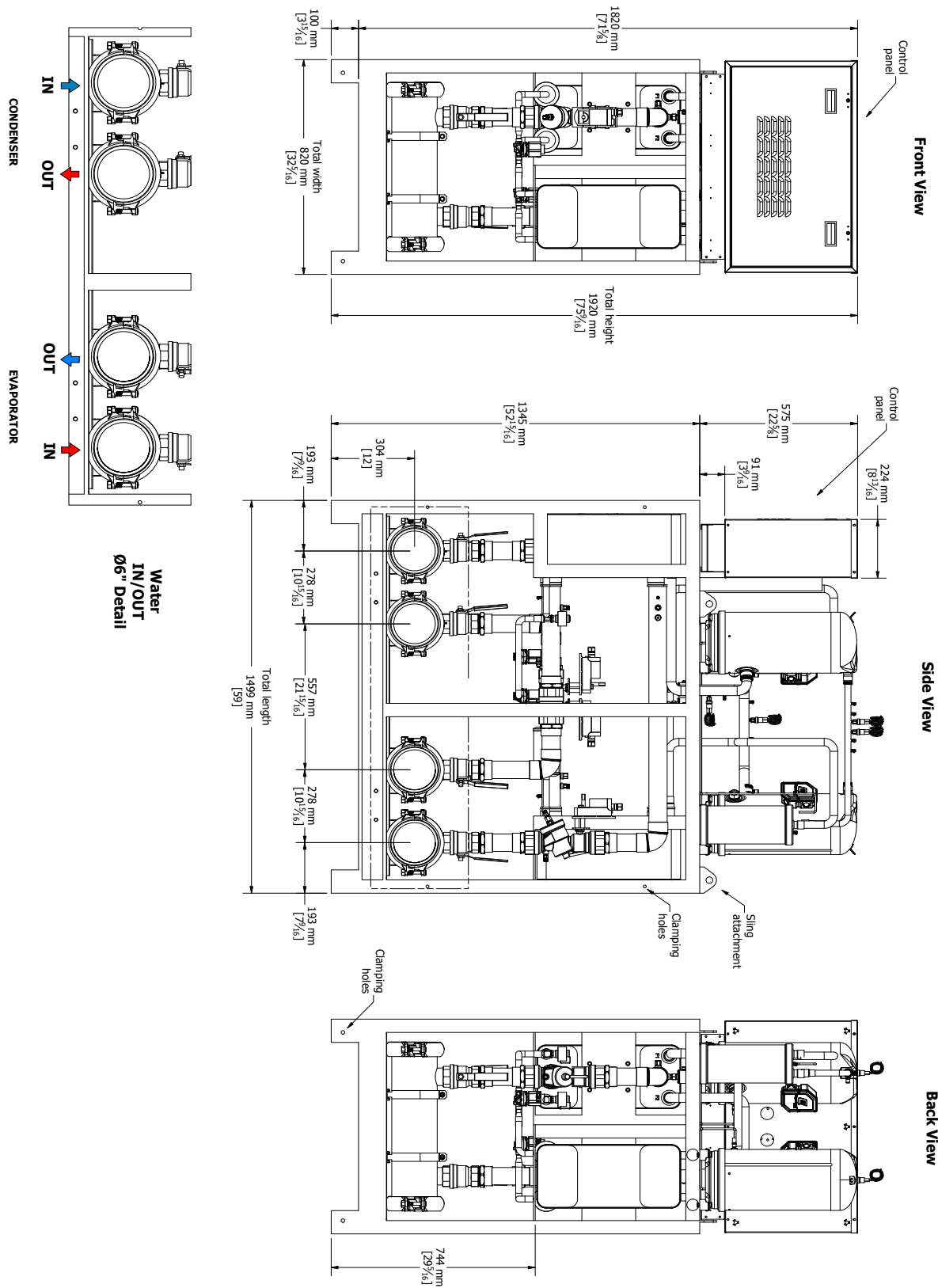

DIMENSIONS AND WEIGHTS - PACKAGED UNITS

Figure 7. CLII tandem

General Specs.

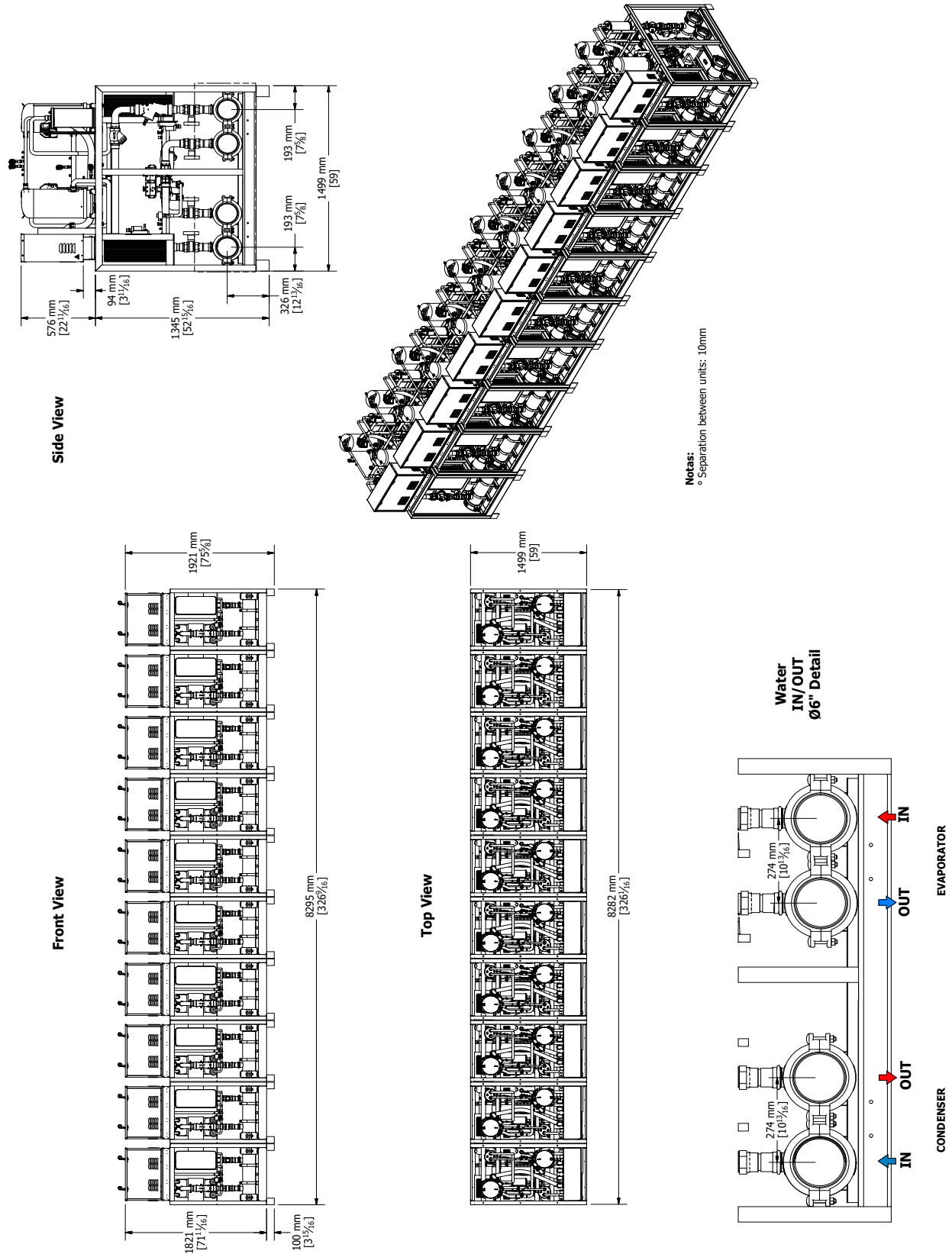

VACUUM AND REFRIGERANT GAS CHARGING PROCEDURE

Any system that has been exposed to the atmosphere must be properly dehydrated. This is achieved with a proper vacuum procedure.

To achieve a proper vacuum, a VACUUM PUMP (not a compressor) and a VACUOMETER are required.

The procedure is as follows:

- First of all, the access points to the system must be defined. For both the low pressure side (suction line) and the high pressure side (liquid line), use the existing service valves on the condensing unit, i.e. the high pressure switch, connected to the smaller diameter pipe, and the low pressure switch, connected to the larger diameter pipe.
- Once this is done, the system can be evacuated.

This can be done in two ways:

Dilution Method

Turn on the vacuum pump and build up vacuum in the pump (register 1 closed). Open register 1 and let the system evacuate until it reaches at least 500 micron. To obtain the measurement, close register 1 and open register 2 and make the vacuum gauge feel the system pressure. After reaching 500 mice, isolate the vacuum pump and open register 3, letting the Nitrogen pass through to break the vacuum. Isolate the Nitrogen tube.

Vent the Nitrogen through the connection between the copper line and register 3.

Repeat the operation at least twice, making the third evacuation in the last phase. At the end at least 200 microns should be obtained.

⚠ WARNING ⚠

Never disconnect the copper tube from register 3, simply loosen the connection to expurge the Nitrogen.

To obtain an accurate vacuum value, isolate the vacuum pump from the system by closing register 1 and waiting about 5 minutes for an accurate measurement. If the value does not hold, the system still has moisture or there is a leak. Always check all connections (points 1, 3 and valves).

High Vacuum Method

It is applied with a vacuum pump capable of achieving a vacuum of less than 200 mice per minute in a single evacuation.

Follow these instructions:

1. Turn on the vacuum pump, then open the register1 (Fig. 12).
2. Subsequently, isolate the vacuum pump and open the register 1 (Fig. 12).
3. When a value of less than 200 microns is obtained (try to reach the lowest possible value), the vacuum procedure is finished.

⚠ WARNING ⚠

The pump oil should be changed periodically to ensure vacuum efficiency.

REFRIGERANT CHARGE

After evacuating the system properly, close the Manifold registers and isolate the vacuum pump, vacuum gauge and Nitrogen tube. To make the refrigerant gas charge, replace the Nitrogen tube (Fig. 12) with a refrigerant gas tube. Purge the hose connecting the tube to the service valve.

Open the service valve that provides access to the refrigerant gas tube and then the Manifold discharge register.

To properly charge the system, check the unit identification labels for the amount of refrigerant gas to be added to the system.

With the system stopped, charge the liquid refrigerant gas through the liquid line service valve (smaller diameter). To assist you, use a scale (if a graduated tube is not used). Wait at least 10 minutes before turning on the equipment.

Close the Manifold discharge register, open the suction register and with the system running complete the charge with refrigerant gas in gas form (5% to 20% of the total). Check on the scale the weight of the refrigerant gas that was added to the system. If the charge is complete close the Manifold suction register, disconnect the suction and discharge hoses and close the pipe register.

The charging procedure is complete.

REFRIGERANT GAS RECOVERY

If for any reason there is a need to remove/lose the refrigerant gas, the service valves on these units allow the refrigerant gas to be collected from the system inside the condensing unit.

Procedure:

1. Connect the Manifold hoses to the service valve vents on the condensing unit.
2. Close 1/4" liquid line service valve.
3. Connect the unit in cooling mode observing that the system pressures reach 2 psig.

At this time close the 3/8" suction line service valve to allow the refrigerant gas to be collected.

NOTE: The refrigerant must be adjusted by 20% to reach the evaporating temperature. You can check the charge on the next page.

REFRIGERANT CHARGE

Table 3. Refrigerant charge - microchannel units

FAMILY	RT	TXV		EXV	
		R410A (LBS)	R410A (KG)	R410A (LBS)	R410A (KG)
CLII	30	1 X 33	1 X 15	1 X 20.5	1 X 9.3
CLII	60	2 X 33	2 X 15	2 X 20.5	2 X 9.3
CLII	90	3 X 33	3 X 15	3 X 20.5	3 X 9.3
CLII	120	4 X 33	4 X 15	4 X 20.5	4 X 9.3
CLII	150	5 X 33	5 X 15	5 X 20.5	5 X 9.3
CLII	180	6 X 33	6 X 15	6 X 20.5	6 X 9.3
CLII	210	7 X 33	7 X 15	7 X 20.5	7 X 9.3
CLII	240	8 X 33	8 X 15	8 X 20.5	8 X 9.3
CLII	270	9 X 33	9 X 15	9 X 20.5	9 X 9.3
CLII	300	10 X 33	10 X 15	10 X 20.5	10 X 9.3

Figure 8. Diagram for obtaining vacuum and for refrigerant charge

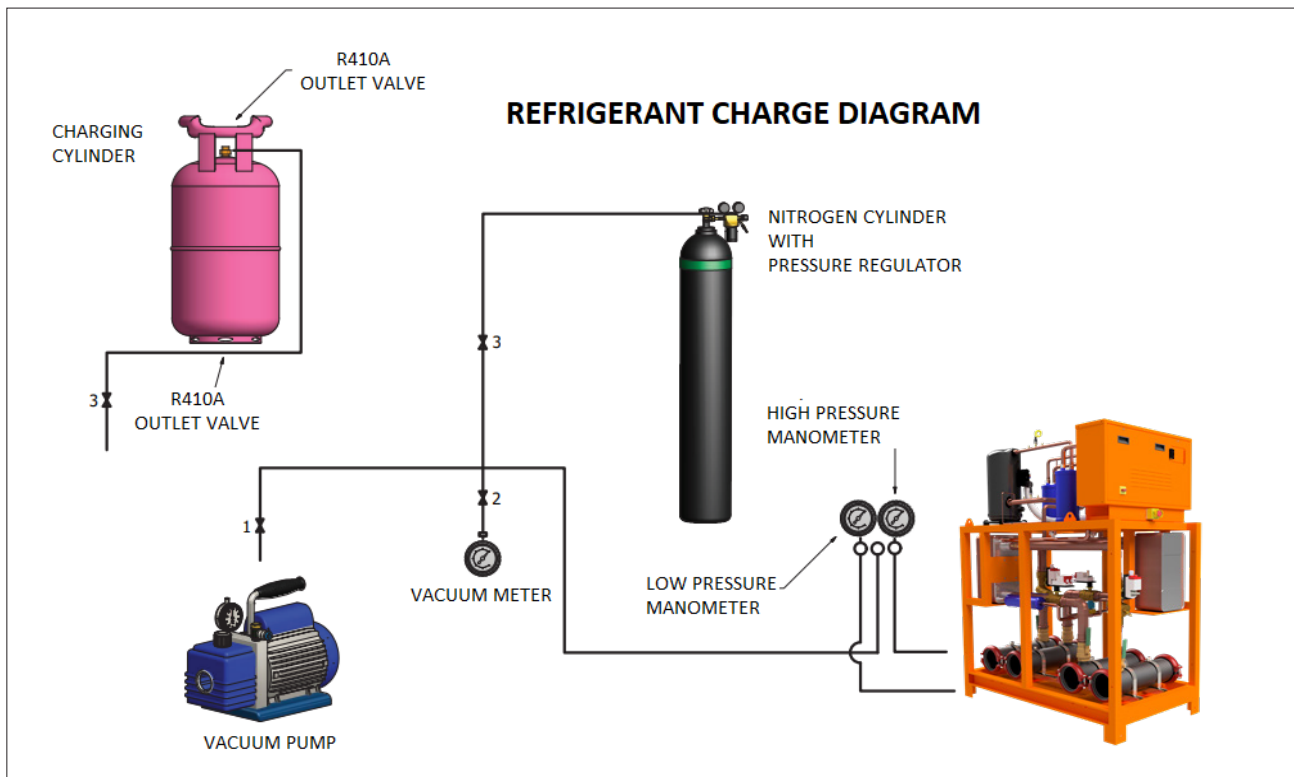

Table 4. Evaporator pressure drop data

UNIT	CAPACITY	# MODULE	LOAD			SOURCE		
			GPM	Φ PIPE SIZE	DP (FT WG)	GPM	Φ PIPE SIZE	DP (FT WG)
M	30	1	72	6	38	90	6	41
M+E	60	2	144	6	41.54	180	6	43.04
M+(E*2)	90	3	216	6	42.38	270	6	44.02
M+(E*3)	120	4	288	6	43.22	360	6	44.9
M+(E*4)	150	5	360	6	44.06	450	6	45.78
M+(E*5)	180	6	432	6	44.9	540	6	46.66
M+(E*6)	210	7	504	6	45.74	630	6	47.54
M+(E*7)	240	8	576	6	46.58	720	6	48.42
M+(E*8)	270	9	648	6	47.42	810	6	49.3
M+(E*9)	300	10	720	6	48.26	900	6	50.18

Figure 9. Units from 30 to 300 tr (Load)

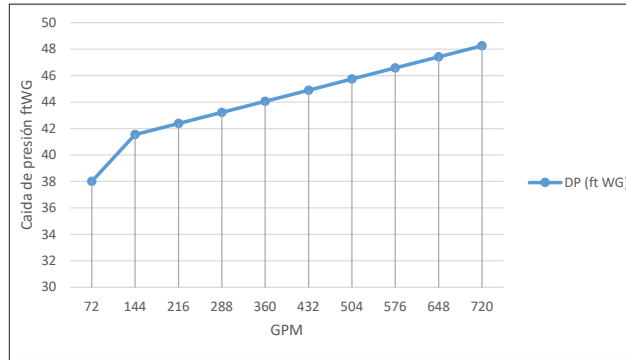
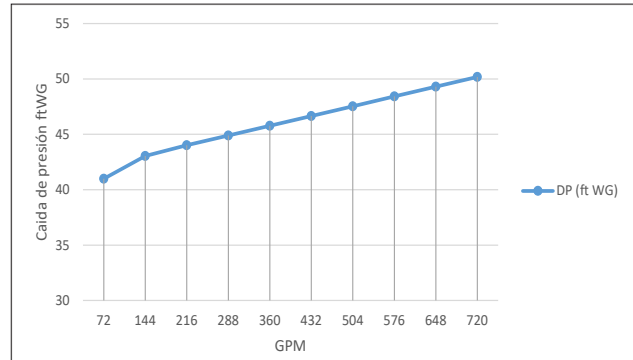

Figure 10. Units from 30 to 300 tr (Source)



ELECTRICAL DATA

ELECTRICAL CONNECTION

CLII units can be ordered with standard multi-point power connections or with optional single-point connections and various disconnect and circuit breaker options. Wiring inside the unit is sized in accordance with the NEC®.

The required field wiring varies depending on the configuration of the unit. Refer to Page 22 through 27 for wiring diagram information. Voltage limitations are:

1. Within 10 percent of nameplate rating.
2. Voltage unbalance should not exceed 2%. Since a voltage unbalance of 2% can cause a current unbalance of 6 to 10 times the voltage unbalance per NEMA MG-1, it is important that phase-to-phase unbalance be kept to a minimum.

⚠ DANGER ⚠

Qualified and licensed electricians must perform wiring. There is an electrical shock hazard that can cause serious injury or death.

⚠ DANGER ⚠

LOCK OUT / DISCONNECT all power sources before starting, pressurizing, depressurizing or shutting down the chiller. Disconnect electrical power before servicing equipment, including compressors. More than one disconnect may be required to deenergize the unit. Failure to comply with this warning can result in serious injury or death. Be sure to read and understand the installation, operating and service instructions in this manual.

Chiller electrical wiring connections may be made with either copper wiring, provided the size and number of wires match the chiller terminals. All wiring must be in accordance with applicable local and national codes, including NECA/AA 10402012 for installation of aluminum wiring in buildings (ANSI).

Wiring within the unit is sized in accordance with the NEC®. Refer to the unit nameplate and unit selection report for correct electrical ratings.

1. The control transformer is supplied and no separate 115V power is required. For single and multipoint power connections, the control transformer is on circuit #1 with control power wired from there to circuit #2. For multipoint power, disconnecting power from circuit #1 disconnects the control power from the unit.
2. The size of the wiring supplied to the control panel should be in accordance with the field wiring diagram.
3. The single point power supply requires a single disconnect to supply electrical power to the unit. This power supply must have a fuse or use a circuit breaker.
4. All field wiring terminal range values listed in the unit selection report apply to 75°C cable per NEC.
5. It must be grounded per national and local electrical codes.

⚠ CAUTION ⚠

Static discharge during handling of the circuit boards can cause damage to the components. Use an antistatic strap before performing any maintenance work. Never unplug cables, circuit board terminal blocks or plugs while the panel is powered.

USE WITH ON-SITE GENERATORS

Switching from site mains to generator power and vice versa requires the chiller to be off or the power to be disconnected for more than five seconds to avoid sending out-of-phase voltage to the chiller.

A properly installed and fully synchronized automatic transfer switch must be used to transfer power if the chiller is operating under load.

Generator sizing

⚠ WARNING ⚠

The generator should be sized by an electrical engineer familiar with generator applications.

Transfer back to the power grid

Proper transfer of power from the standby generator to the grid is essential to prevent damage to the chiller and must be used to ensure proper operation of the unit.

⚠ WARNING ⚠

Stop the chiller before transferring power from the generator to the mains. Transferring power while the chiller is running can cause serious damage to the chiller.

The procedure required to reconnect generator power to the grid is as follows:

1. Set the generator to always run five minutes longer than the unit start timer, which can be set from two to sixty minutes, while keeping the chiller powered by the generator until the fully synchronized Automatic Transfer Switch properly delivers chiller power from the site.
2. Set the transfer switch supplied with the generator to automatically shut down the chiller before the transfer is made. The automatic shutdown function can be accomplished through a BAS interface or with the "remote on/off" wiring connection shown in the field wiring diagrams. A start signal can be given at any time after the stop signal, as the three-minute start timer will be in effect.

⚠ WARNING ⚠

Electric shock danger. Improper handling of this equipment can cause personal injury or equipment damage. This equipment must be properly grounded. Control panel connections and maintenance should be performed only by personnel knowledgeable in the operation of the equipment being controlled. Disconnect electrical power before servicing equipment. Be sure to install a earth leakage breaker. Failure to install a earth leakage breaker may result in electric shock or fire.

⚠ WARNING ⚠

When installing the earth leakage protector make sure that it is compatible with the inverter (resistant to high frequency electrical noise) to avoid unnecessary opening of the earth leakage protector.ra.

ELECTRICAL DATA

Figure 11. Typical field wiring diagram of CLII unit with thermostatic valve 220V (single-point connection with all options shown)

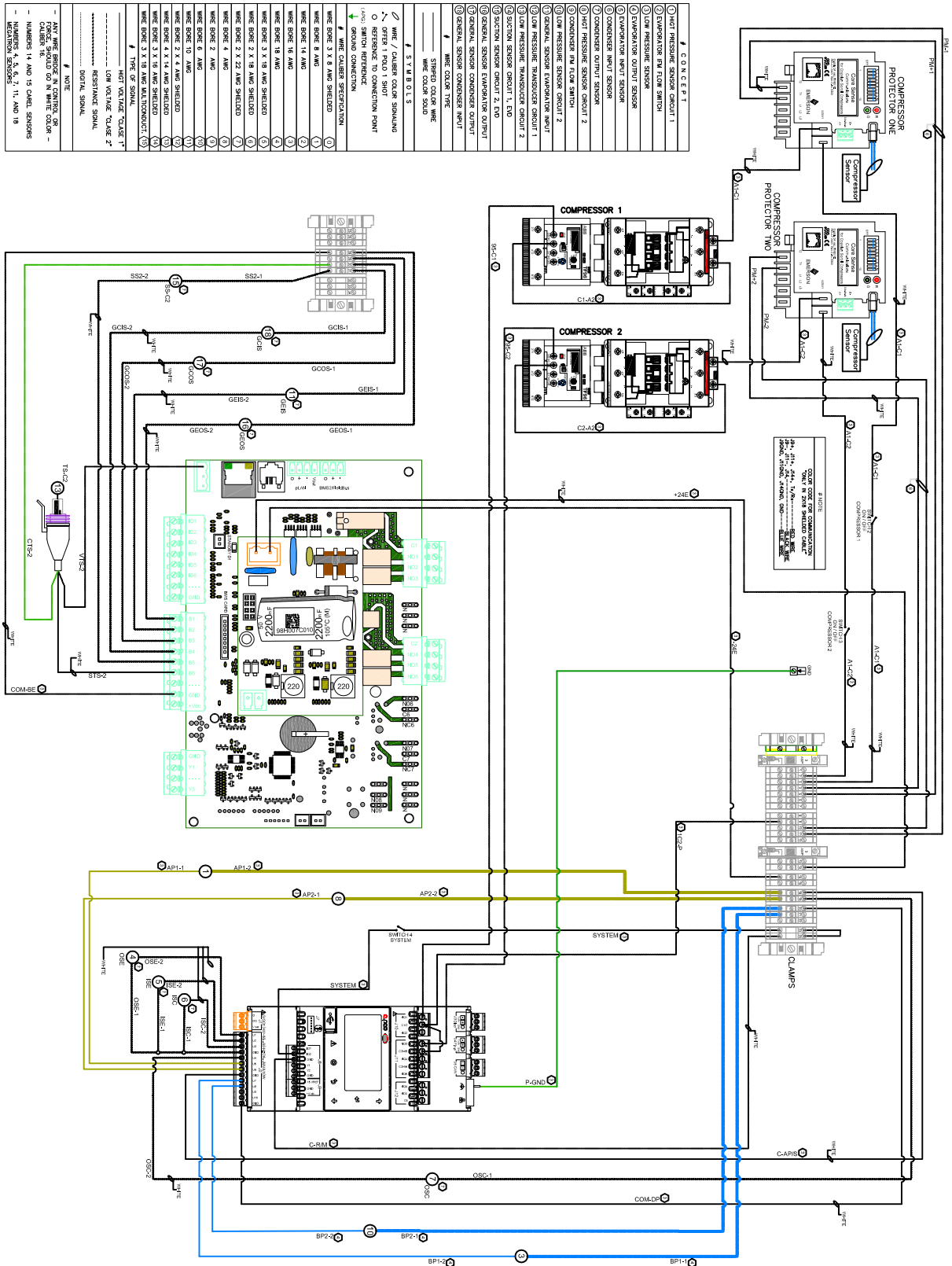

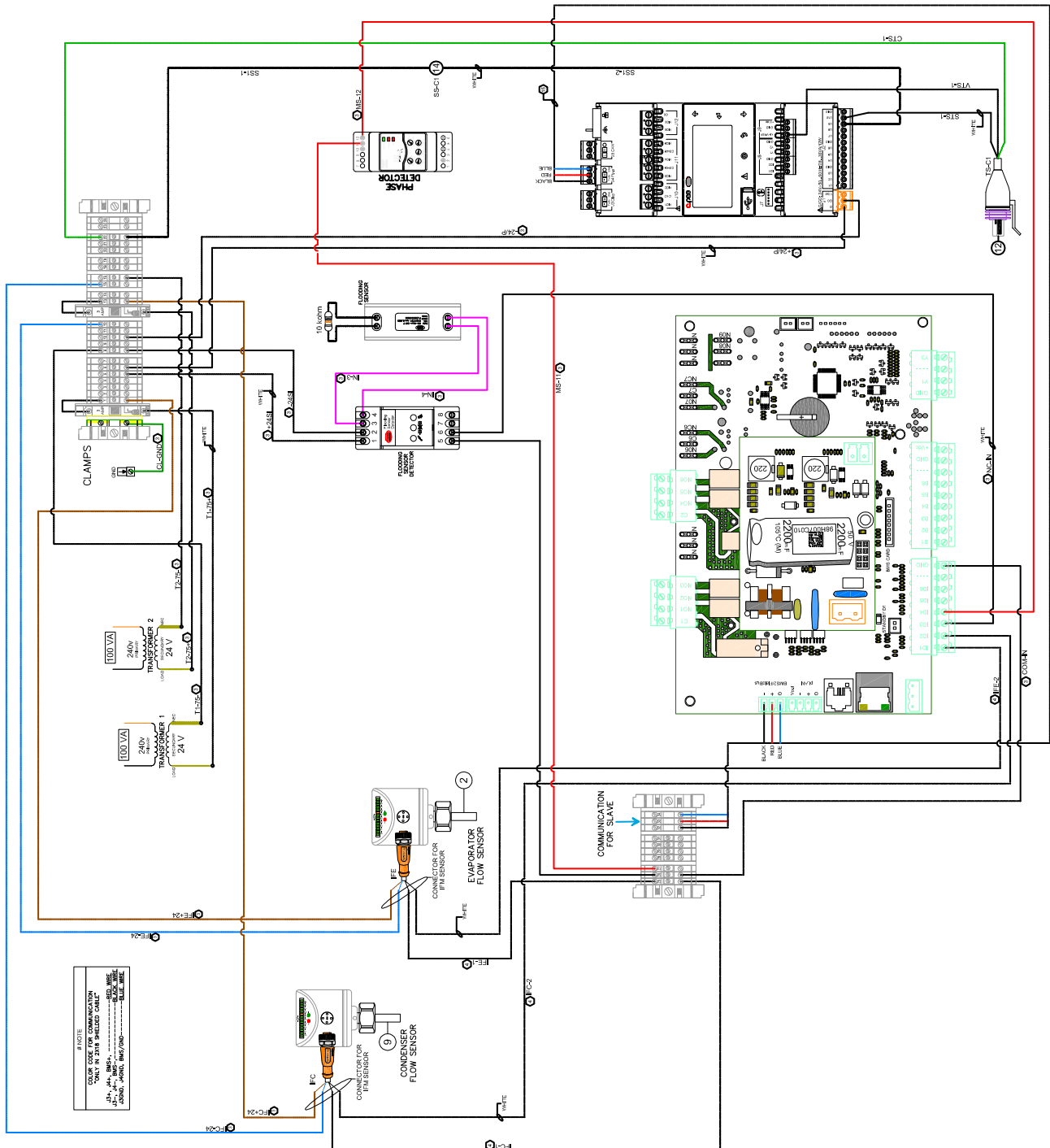
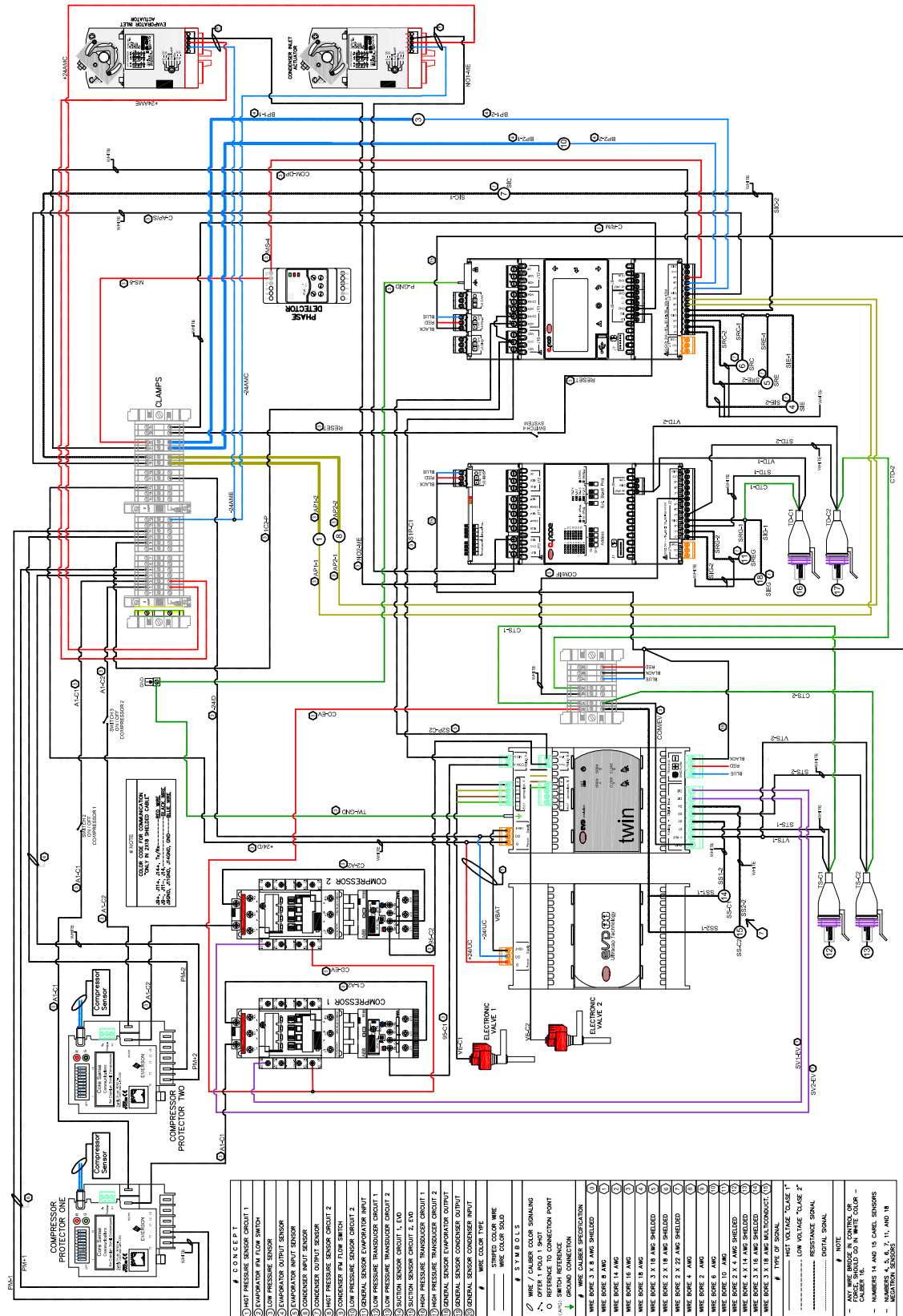
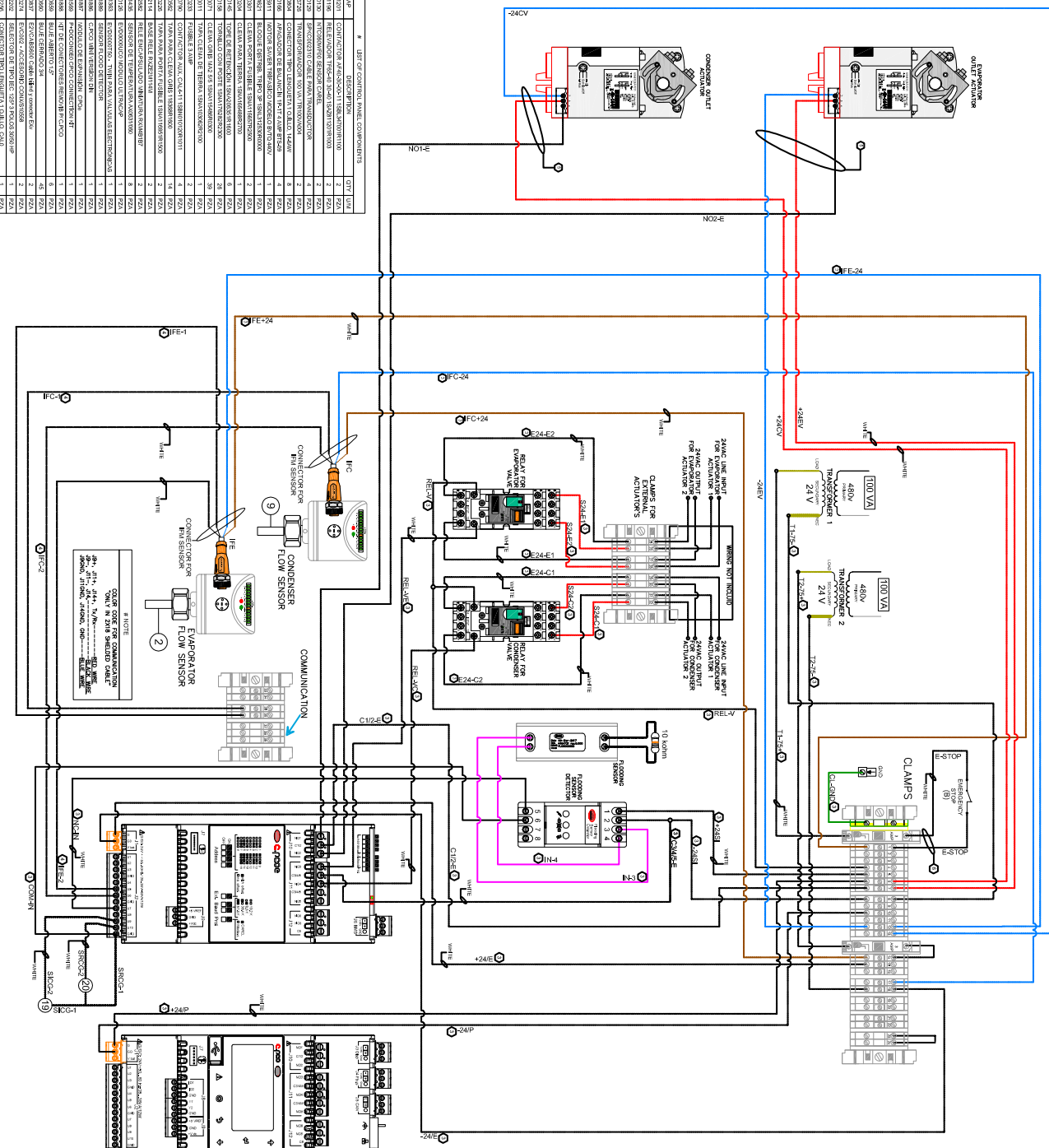

Figure 12. Typical field wiring diagram of CLII unit with electronic valve 440V (single-point connection with all options shown)



ELECTRICAL DATA

#	LIST OF CONTROL PANEL COMPONENTS	QTY	UNIT
000001	CONTROL PANEL	1	PCB
000002	CONTROL PANEL	1	PCB
000003	CONTROL PANEL	1	PCB
000004	CONTROL PANEL	1	PCB
000005	CONTROL PANEL	1	PCB
000006	CONTROL PANEL	1	PCB
000007	CONTROL PANEL	1	PCB
000008	CONTROL PANEL	1	PCB
000009	CONTROL PANEL	1	PCB
000010	CONTROL PANEL	1	PCB
000011	CONTROL PANEL	1	PCB
000012	CONTROL PANEL	1	PCB
000013	CONTROL PANEL	1	PCB
000014	CONTROL PANEL	1	PCB
000015	CONTROL PANEL	1	PCB
000016	CONTROL PANEL	1	PCB
000017	CONTROL PANEL	1	PCB
000018	CONTROL PANEL	1	PCB
000019	CONTROL PANEL	1	PCB
000020	CONTROL PANEL	1	PCB
000021	CONTROL PANEL	1	PCB
000022	CONTROL PANEL	1	PCB
000023	CONTROL PANEL	1	PCB
000024	CONTROL PANEL	1	PCB
000025	CONTROL PANEL	1	PCB
000026	CONTROL PANEL	1	PCB
000027	CONTROL PANEL	1	PCB
000028	CONTROL PANEL	1	PCB
000029	CONTROL PANEL	1	PCB
000030	CONTROL PANEL	1	PCB
000031	CONTROL PANEL	1	PCB
000032	CONTROL PANEL	1	PCB
000033	CONTROL PANEL	1	PCB
000034	CONTROL PANEL	1	PCB
000035	CONTROL PANEL	1	PCB
000036	CONTROL PANEL	1	PCB
000037	CONTROL PANEL	1	PCB
000038	CONTROL PANEL	1	PCB
000039	CONTROL PANEL	1	PCB
000040	CONTROL PANEL	1	PCB
000041	CONTROL PANEL	1	PCB
000042	CONTROL PANEL	1	PCB
000043	CONTROL PANEL	1	PCB
000044	CONTROL PANEL	1	PCB
000045	CONTROL PANEL	1	PCB
000046	CONTROL PANEL	1	PCB
000047	CONTROL PANEL	1	PCB
000048	CONTROL PANEL	1	PCB
000049	CONTROL PANEL	1	PCB
000050	CONTROL PANEL	1	PCB
000051	CONTROL PANEL	1	PCB
000052	CONTROL PANEL	1	PCB
000053	CONTROL PANEL	1	PCB
000054	CONTROL PANEL	1	PCB
000055	CONTROL PANEL	1	PCB
000056	CONTROL PANEL	1	PCB
000057	CONTROL PANEL	1	PCB
000058	CONTROL PANEL	1	PCB
000059	CONTROL PANEL	1	PCB
000060	CONTROL PANEL	1	PCB
000061	CONTROL PANEL	1	PCB
000062	CONTROL PANEL	1	PCB
000063	CONTROL PANEL	1	PCB
000064	CONTROL PANEL	1	PCB
000065	CONTROL PANEL	1	PCB
000066	CONTROL PANEL	1	PCB
000067	CONTROL PANEL	1	PCB
000068	CONTROL PANEL	1	PCB
000069	CONTROL PANEL	1	PCB
000070	CONTROL PANEL	1	PCB
000071	CONTROL PANEL	1	PCB
000072	CONTROL PANEL	1	PCB
000073	CONTROL PANEL	1	PCB
000074	CONTROL PANEL	1	PCB
000075	CONTROL PANEL	1	PCB
000076	CONTROL PANEL	1	PCB
000077	CONTROL PANEL	1	PCB
000078	CONTROL PANEL	1	PCB
000079	CONTROL PANEL	1	PCB
000080	CONTROL PANEL	1	PCB
000081	CONTROL PANEL	1	PCB
000082	CONTROL PANEL	1	PCB
000083	CONTROL PANEL	1	PCB
000084	CONTROL PANEL	1	PCB
000085	CONTROL PANEL	1	PCB
000086	CONTROL PANEL	1	PCB
000087	CONTROL PANEL	1	PCB
000088	CONTROL PANEL	1	PCB
000089	CONTROL PANEL	1	PCB
000090	CONTROL PANEL	1	PCB
000091	CONTROL PANEL	1	PCB
000092	CONTROL PANEL	1	PCB
000093	CONTROL PANEL	1	PCB
000094	CONTROL PANEL	1	PCB
000095	CONTROL PANEL	1	PCB
000096	CONTROL PANEL	1	PCB
000097	CONTROL PANEL	1	PCB
000098	CONTROL PANEL	1	PCB
000099	CONTROL PANEL	1	PCB
000100	CONTROL PANEL	1	PCB



- CONCEPT**
- ① HOT PRESSURE SENSOR CIRCUIT 1
 - ② EVAPORATOR FLOW SWITCH
 - ③ LOW PRESSURE SENSOR
 - ④ EVAPORATOR OUTPUT SENSOR
 - ⑤ EVAPORATOR INPUT SENSOR
 - ⑥ CONDENSER INPUT SENSOR
 - ⑦ CONDENSER OUTPUT SENSOR
 - ⑧ HOT PRESSURE SENSOR CIRCUIT 2
 - ⑨ HOT PRESSURE FLOW SWITCH
 - ⑩ GENERAL SENSOR EVAPORATOR INPUT
 - ⑪ LOW PRESSURE TRANSDUCER CIRCUIT 1
 - ⑫ LOW PRESSURE TRANSDUCER CIRCUIT 2
 - ⑬ SUCTION SENSOR CIRCUIT 1 EPO
 - ⑭ SUCTION SENSOR CIRCUIT 2 EPO
 - ⑮ SUCTION SENSOR CIRCUIT 1 EPO
 - ⑯ SUCTION SENSOR CIRCUIT 2 EPO
 - ⑰ HIGH PRESSURE TRANSDUCER CIRCUIT 1
 - ⑱ HIGH PRESSURE TRANSDUCER CIRCUIT 2
 - ⑲ GENERAL SENSOR EVAPORATOR OUTPUT
 - ⑳ GENERAL SENSOR CONDENSER OUTPUT
 - ㉑ GENERAL SENSOR CONDENSER INPUT
- WIRE COLOR TYPE**
- STRIPED COLOR WIRE
 - WIRE COLOR SOLID
 - 5 V V B O L S
- WIRE / CABLE COLOR MARKING**
- ~ AFTER 1 POLE 1 SHOT
 - (S) SWITCH REFERENCE
 - (S) SWITCH REFERENCE
 - GROUND CONNECTION
- WIRE CABLE SPECIFICATION**
- ① WIRE BORE 3 X 8 AWG SHIELDED
 - ② WIRE BORE 8 AWG
 - ③ WIRE BORE 14 AWG
 - ④ WIRE BORE 16 AWG
 - ⑤ WIRE BORE 18 AWG
 - ⑥ WIRE BORE 3 X 18 AWG SHIELDED
 - ⑦ WIRE BORE 2 X 22 AWG SHIELDED
 - ⑧ WIRE BORE 4 AWG
 - ⑨ WIRE BORE 6 AWG
 - ⑩ WIRE BORE 10 AWG
 - ⑪ WIRE BORE 3 X 14 AWG SHIELDED
 - ⑫ WIRE BORE 5 X 14 AWG SHIELDED
 - ⑬ WIRE BORE 3 X 18 AWG MULTICONDUCT
 - ⑭ WIRE BORE 3 X 18 AWG MULTICONDUCT
 - ⑮ TYPE OF SIGNAL
- HIGH VOLTAGE "CLASS 1"**
- LOW VOLTAGE "CLASS 2"
- RESISTANCE SIGNAL
- DIGITAL SIGNAL
- NOTE**
- ANY WIRE BORE IN CONTROL OR CABLE 16
 - NUMBERS 14 AND 15 CABLE SENSORS
 - NUMBERS 4, 5, 6, 7, 11, AND 18 MECHANICAL SENSORS

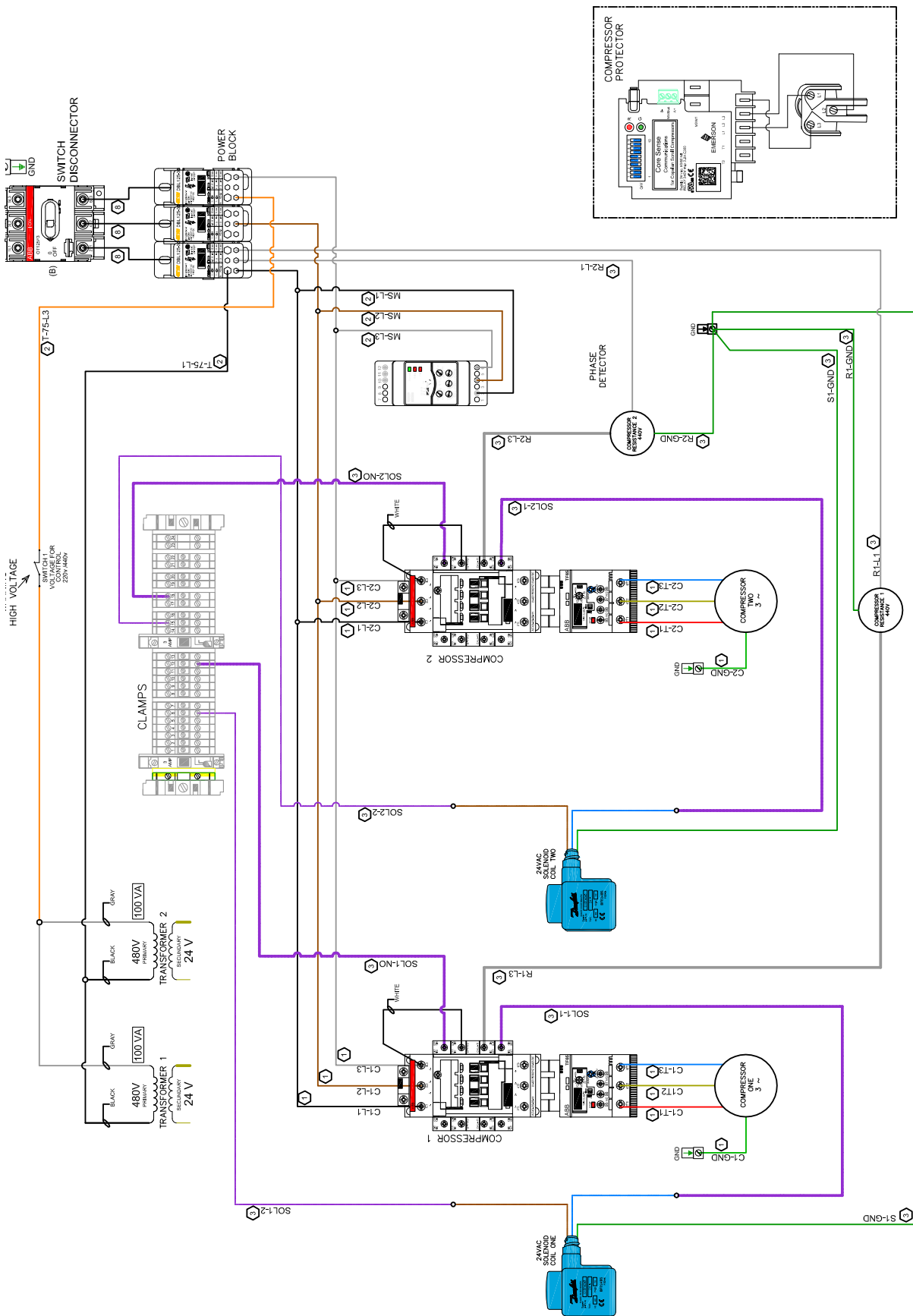

UNIT CONTROLLER OPERATION

GENERAL DESCRIPTION

The c.PCO is an electronically programmable microprocessor-based controller that is fully compatible (software and hardware) with the c.PCO family of products and systems that include programmable controllers, user terminals, gateways, communication devices and remote device management. These devices represent a powerful control system that can be easily linked with the vast majority of Building Management Systems (BSM) available on the market.

The controller menu can be accessed from a touch screen, this screen has all the parameters and the operating status of the equipment.

The c.PCO continuously performs pre-failure scans of the equipment status to prevent damage to parts and components if a failure occurs.

The controller menu contains different screens and submenus that provide the operator or service technician with a complete description of:

1. User.
2. Maintenance.
3. Service Manufacturing

Figure 13. System Architecture

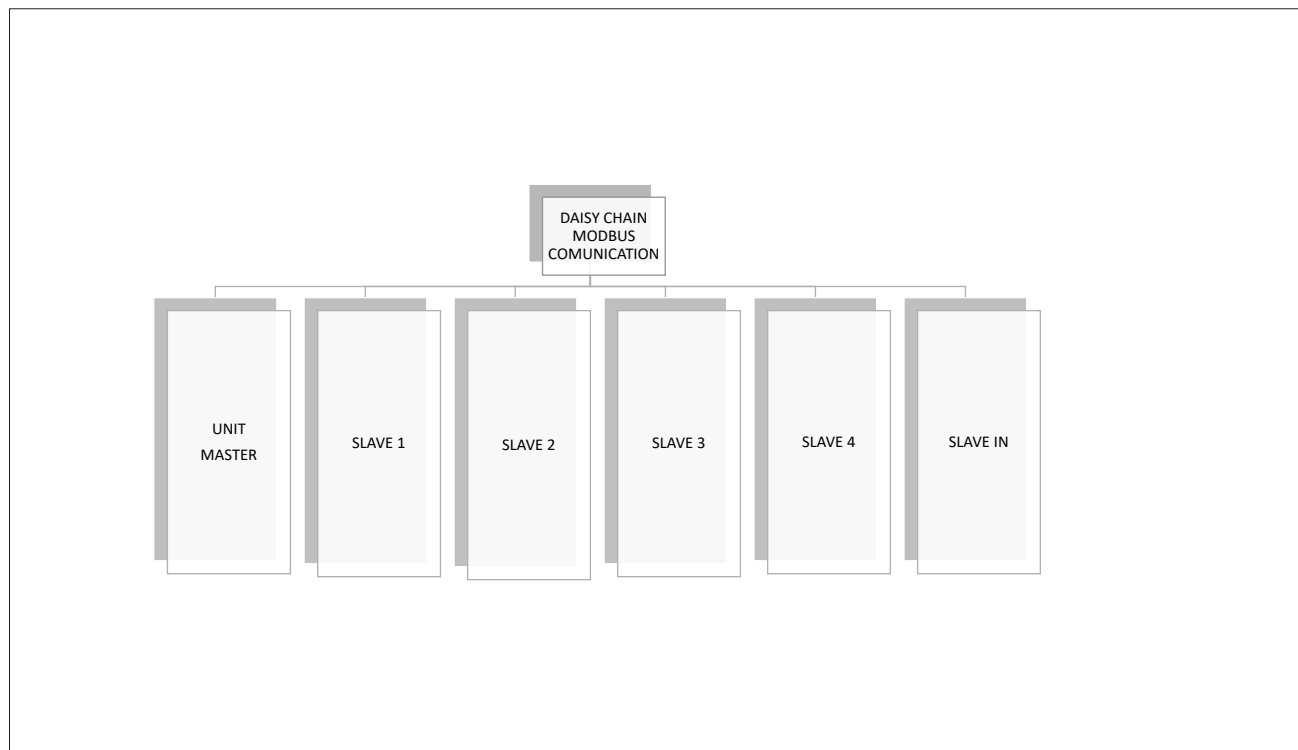

SYSTEM ARCHITECTURE

The general architecture of the controls uses the following:

- A c.PCO unit controller.
- I/O extension modules as required depending on the unit configuration.
- Communications interface slave modules.
- The units in the architecture have a configuration based on a MASTER unit and unit I/O slaves, these slaves can be connected via rs485 serial Modbus and can be configured from the configuration screen.

All I/O slave modules can be connected directly or via a wiring harness.

The connection order of the slaves can be from left to right or from right to left, always respecting the master as the main unit.

CLII MODEL INLETS AND OUTLETS WITH ELECTRONIC EXPANSION VALVE FOR COOLING AND HEAT PUMP MODE.

Table 5. Analog inputs C.PCO (mini high end) MASTER

#	DESCRIPTION	SIGNAL TYPE
U1	EVAPORATOR 1 INJECTION SENSOR	NTC
U2	EVAPORATOR 1 RETURN SENSOR	NTC
U3	SENSOR RETURN CAPACITOR 1	NTC
U4	SENSOR INJECTION CONDENSER 1	NTC
J3	SERIAL COMMUNICATION	VCD

Table 6. Analog inputs C.PCOE MASTER

#	DESCRIPTION	SIGNAL TYPE
U1	GENERAL INJECTION SENSOR	NTC
U2	GENERAL RETURN SENSOR	NTC
U3	HIGH PRESSURE TRANSDUCER CIRCUIT 1	RADIOMETRIC .5 TO 4.5VCD
U4	HIGH PRESSURE TRANSDUCER CIRCUIT 2	RADIOMETRIC .5 TO 4.5 VCD
J6	SERIAL COMMUNICATION	VCD

Table 7. Analog inputs EVD TWIN MASTER

#	DESCRIPTION	SIGNAL TYPE
S1	LOW PRESSURE TRANSDUCER CIRCUIT 1	RADIOMETRIC .5 TO 4.5VCD
S2	SUCTION SENSOR CIRCUIT 1	NTC
S3	LOW PRESSURE TRANSDUCER CIRCUIT 2	RADIOMETRIC .5 TO 4.5VCD
S4	SUCTION SENSOR CIRCUIT 2	NTC
NETWORK	SERIAL COMMUNICATION	VCD

Table 8. Digital inputs C.PCO (mini high end) MASTER

#	DESCRIPTION	SIGNAL TYPE
ID1	MODE (HOT/COLD)	DRY CONTACT
ID2	RESET	DRY CONTACT
U5	HIGH PRESSURE SWITCH CIRCUIT 1	DRY CONTACT
U6	HIGH PRESSURE SWITCH CIRCUIT 2	DRY CONTACT
U7	LOW PRESSURE SWITCH CIRCUIT 1	DRY CONTACT
U8	LOW PRESSURE SWITCH CIRCUIT 2	DRY CONTACT
U9	SAVER MOTOR	DRY CONTACT

UNIT CONTROLLER OPERATION

Table 10. Digital inputs C.PCOE MASTER

#	DESCRIPTION	SIGNAL TYPE
U5	EVAPORATOR THERMAL DISPERSION SENSOR	DRY CONTACT
U6	CONDENSER THERMAL DISPERSION SENSOR	DRY CONTACT
U7	FLOODING SENSOR	DRY CONTACT

Table 9. Digital inputs EVD TWIN MASTER

#	DESCRIPTION	SIGNAL TYPE
DI1	COMPRESSOR IGNITION 1	DRY CONTACT
DI2	COMPRESSOR IGNITION 2	DRY CONTACT

Table 11. Analogous Outputs C.PCOE MASTER

#	DESCRIPTION	SIGNAL TYPE
+5 V REF	HIGH PRESSURE TRANSDUCERS CIRCUIT 1 AND 2	5VCD

Table 12. Analog outputs EVD TWIN MASTER

#	DESCRIPTION	SIGNAL TYPE
V REF	HIGH PRESSURE TRANSDUCERS CIRCUIT 1 AND 2	5VDC
EXV CONNECTION A	ELECTRONIC EXPANSION VALVE 1	VCD PULSES (STEPPER MOTOR CONTROLLER)
EXV CONNECTION B	ELECTRONIC EXPANSION VALVE 2	VCD PULSES (STEPPER MOTOR CONTROLLER)

Table 13. Digital outputs C.PCO (mini high end) MASTER

#	DESCRIPTION	SIGNAL TYPE
NO1	COMPRESSOR IGNITION 1 RELAY A (EVD TWIN)	DRY CONTACT
NO3	COMPRESSOR IGNITION 2 RELAY B (EVD TWIN)	DRY CONTACT
NO5	4 WAY VALVE IGNITION CIRCUIT 1 AND 2 (HEAT PUMP UNITS ONLY)	DRY CONTACT

Table 14. Digital Outputs C.PCOE MASTER

#	DESCRIPTION	SIGNAL TYPE
NO1	CONDENSER ACTUATOR IGNITION	DRY CONTACT
NO2	EVAPORATOR ACTUATOR IGNITION	DRY CONTACT
NO3	A1 RELAY COIL FOR EVAPORATOR VALVE	DRY CONTACT
NO4	A1 RELAY COIL FOR EVAPORATOR VALVE	DRY CONTACT

Table 15. Digital outputs EVD TWIN MASTER

#	DESCRIPTION	SIGNAL TYPE
RELAY A	OUTPUT TO COMPRESSOR 1 OVERLOAD RELAY (NC-95)	DRY CONTACT
RELAY B	OUTPUT TO COMPRESSOR 2 OVERLOAD RELAY (NC-95)	DRY CONTACT

Table 16. Analog inputs C.PCOE (1) SLAVE

#	DESCRIPTION	SIGNAL TYPE
U1	EVAPORATOR 1 INJECTION SENSOR	NTC
U2	EVAPORATOR RETURN SENSOR 1	NTC
U3	CONDENSER RETURN SENSOR 1	NTC
U4	CONDENSER INJECTION SENSOR CONDENSER 1	NTC
J6	SERIAL COMMUNICATION	VCD

Table 17. Analog inputs C.PCOE (2) SLAVE

#	DESCRIPTION	SIGNAL TYPE
U3	HIGH PRESSURE TRANSDUCER CIRCUIT 1	RADIOMETRIC .5 TO 4.5VCD
U4	HIGH PRESSURE TRANSDUCER CIRCUIT 1	RADIOMETRIC .5 TO 4.5VCD
J6	SERIAL COMMUNICATION	VCD

Table 18. Analog inputs EVD TWIN SLAVE

#	DESCRIPTION	SIGNAL TYPE
S1	LOW PRESSURE TRANSDUCER CIRCUIT 1	RADIOMETRIC .5 TO 4.5VCD
S2	SUCTION SENSOR CIRCUIT 1	NTC
S3	LOW PRESSURE TRANSDUCER CIRCUIT 2	RADIOMETRIC .5 TO 4.5VCD
S4	SUCTION SENSOR CIRCUIT 2	NTC
NETWORK	SERIAL COMMUNICATION	VCD

Table 19. Digital inputs C.PCOE (1) SLAVE

#	DESCRIPTION	SIGNAL TYPE
U5	HIGH PRESSURE SWITCH CIRCUIT 1	DRY CONTACT
U6	HIGH PRESSURE SWITCH CIRCUIT 2	DRY CONTACT
U7	LOW PRESSURE SWITCH CIRCUIT 1	DRY CONTACT
U8	LOW PRESSURE SWITCH CIRCUIT 2	DRY CONTACT
U9	SAVER MOTOR	DRY CONTACT

UNIT CONTROLLER OPERATION

Table 20. Digital inputs C.PCOE (2) SLAVE

#	DESCRIPTION	SIGNAL TYPE
U5	EVAPORATOR THERMAL DISPERSION SENSOR	DRY CONTACT
U6	CONDENSER THERMAL DISPERSION SENSOR	DRY CONTACT
U7	FLOODING SENSOR	DRY CONTACT

Table 21. Digital inputs EVD TWIN SLAVE

#	DESCRIPTION	SIGNAL TYPE
DI1	COMPRESSOR 1 IGNITION	DRY CONTACT
DI2	COMPRESSOR 2 IGNITION	DRY CONTACT

Table 22. Analog outputs C.PCOE SLAVE

#	DESCRIPTION	SIGNAL TYPE
+5 V REF	HIGH PRESSURE TRANSDUCERS CIRCUIT 1 AND 2	5VCD

Table 23. Analog outputs EVD TWIN SLAVE

#	DESCRIPTION	SIGNAL TYPE
V REF	HIGH PRESSURE TRANSDUCERS CIRCUIT 1 AND 2	5VDC
EXV CONNECTION A	ELECTRONIC EXPANSION VALVE 1	VCD PULSES (STEPPER MOTOR CONTROLLER)
EXV CONNECTION B	ELECTRONIC EXPANSION VALVE 2	VCD PULSES (STEPPER MOTOR CONTROLLER)

Table 24. Digital outputs C.PCOE (1) SLAVE

#	DESCRIPTION	SIGNAL TYPE
NO1	COMPRESSOR IGNITION 1 RELAY A (EVD TWIN)	DRY CONTACT
NO3	COMPRESSOR IGNITION 2 RELAY B (EVD TWIN)	DRY CONTACT
NO5	4-WAY VALVE IGNITION CIRCUIT 1 AND 2 (HEAT PUMP UNITS ONLY)	DRY CONTACT

Table 25. Digital outputs C.PCOE (2) SLAVE

#	DESCRIPTION	SIGNAL TYPE
NO1	CONDENSER ACTUATOR IGNITION	DRY CONTACT
NO2	2 RELAY B COMPRESSOR IGNITION (EVD TWIN)	DRY CONTACT

Table 26. Digital outputs EVD TWIN SLAVE

#	DESCRIPTION	SIGNAL TYPE
RELAY A	OUTPUT TO COMPRESSOR 1 OVERLOAD RELAY (NC-95)	DRY CONTACT
RELAY B	OUTPUT TO COMPRESSOR 2 OVERLOAD RELAY (NC-95)	DRY CONTACT

CLII MODEL INLETS AND OUTLETS WITH THERMOSTATIC EXPANSION VALVE FOR COOLING MODE

Table 27. Analog inputs C.PCO (mini high end) MASTER

#	DESCRIPTION	SIGNAL TYPE
U1	EVAPORATOR 1 INJECTION SENSOR	NTC
U2	EVAPORATOR 1 RETURN SENSOR	NTC
U3	CONDENSER RETURN SENSOR 1	NTC
U4	CONDENSER INJECTION SENSOR 1	NTC
U9	COMPRESSOR SUCTION SENSOR 1	NTC
U10	COMPRESSOR SUCTION TRANSDUCER 1	RADIOMETRIC FROM .5 TO 4.5 VCD
J3	SERIAL COMMUNICATION	VCD

Table 28. Analog inputs micro PCO MASTER

#	DESCRIPTION	SIGNAL TYPE
B1	EVAPORATOR GENERAL INJECTION SENSOR	NTC
B2	EVAPORATOR GENERAL RETURN SENSOR	NTC
B3	GENERAL CONDENSER RETURN SENSOR	NTC
B4	GENERAL CONDENSER INJECTION SENSOR	NTC
B5	COMPRESSOR 2 SUCTION SENSOR	NTC
B6	COMPRESSOR 2 SUCTION TRANSDUCER	RADIOMETRIC FROM .5 TO 4.5 VCD
+O	SERIAL COMMUNICATION	VCD

Table 29. Digital inputs C.PCO (mini high end) MASTER

#	DESCRIPTION	SIGNAL TYPE
ID1	SYSTEM	DRY CONTACT
U5	HIGH PRESSURE SWITCH CIRCUIT 1	DRY CONTACT
U6	HIGH PRESSURE SWITCH CIRCUIT 2	DRY CONTACT
U7	LOW PRESSURE SWITCH CIRCUIT 1	DRY CONTACT
U8	LOW PRESSURE SWITCH CIRCUIT 2	DRY CONTACT

Table 30. Digital inputs micro PCO MASTER

#	DESCRIPTION	SIGNAL TYPE
DI1	THERMAL DISPERSION SENSOR	DRY CONTACT
DI2	THERMAL DISPERSION SENSOR	DRY CONTACT
DI4	SAVER MOTOR	DRY CONTACT

UNIT CONTROLLER OPERATION

Table 31. Analog outputs C.PCO (mini high end) MASTER

#	DESCRIPTION	SIGNAL TYPE
+5 V REF	LOW PRESSURE TRANSDUCERS CIRCUIT 1	5VDC

Table 32. Analog output micro PCO MASTER

#	DESCRIPTION	SIGNAL TYPE
+5VR	LOW PRESSURE TRANSDUCERS CIRCUIT 2	5VDC

Table 33. Digital outputs C.PCO (mini high end) MASTER

#	DESCRIPTION	SIGNAL TYPE
NO1	COMPRESSOR IGNITION 1 RELAY A (EVD TWIN)	DRY CONTACT
NO3	COMPRESSOR IGNITION 2 RELAY B (EVD TWIN)	DRY CONTACT

Table 34. Analog inputs micro PCO (1) SLAVE

#	DESCRIPTION	SIGNAL TYPE
B1	EVAPORATOR INJECTION SENSOR	NTC
B2	EVAPORATOR RETURN SENSOR	NTC
B3	CONDENSER RETURN SENSOR	NTC
B4	CONDENSER INJECTION SENSOR	NTC
B5	COMPRESSOR SUCTION SENSOR 1	NTC
B6	COMPRESSOR SUCTION TRANSDUCER 1	RADIOMETRIC FROM .5 TO 4.5 VCD
+ -O	SERIAL COMMUNICATION	VCD

Table 35. Analog micro PCO inputs (2) SLAVE

#	DESCRIPTION	SIGNAL TYPE
B5	COMPRESSOR SUCTION SENSOR 2	NTC
B6	COMPRESSOR SUCTION TRANSDUCER 2	RADIOMETRIC .5 TO 4.5 VCD
+ -O	SERIAL COMMUNICATION	VCD

Table 36. Micro PCO digital inputs (1) SLAVE

#	DESCRIPTION	SIGNAL TYPE
DI1	HIGH PRESSURE SWITCH CIRCUIT 1	DRY CONTACT
DI2	HIGH PRESSURE SWITCH CIRCUIT 2	DRY CONTACT
DI3	LOW PRESSURE SWITCH CIRCUIT 1	DRY CONTACT
DI4	LOW PRESSURE SWITCH CIRCUIT 2	DRY CONTACT
DI5	SAVER MOTOR	DRY CONTACT

Table 37. Digital micro PCO inputs (2) SLAVE

#	DESCRIPTION	SIGNAL TYPE
DI1	EVAPORATOR THERMAL DISPERSION SENSOR	DRY CONTACT
DI2	CONDENSER THERMAL DISPERSION SENSOR	DRY CONTACT

Table 38. Analog outputs micro PCO (1) SLAVE

#	DESCRIPTION	SIGNAL TYPE
+5VR	LOW PRESSURE TRANSDUCER CIRCUIT 1	5VDC

Table 39. Analog outputs micro PCO (2) SLAVE

#	DESCRIPTION	SIGNAL TYPE
+5VR	LOW PRESSURE TRANSDUCER CIRCUIT 2	5VDC

Table 40. Digital micro PCO outputs (1) SLAVE

#	DESCRIPTION	SIGNAL TYPE
NO1	COMPRESSOR IGNITION 1 RELAY A (EVD TWIN)	DRY CONTACT
NO2	COMPRESSOR IGNITION 2 RELAY B (EVD TWIN)	DRY CONTACT

Table 41. Digital micro PCO outputs (2) SLAVE

#	DESCRIPTION	SIGNAL TYPE
NO2	EVAPORATOR ACTUATOR IGNITION	DRY CONTACT

SET POINTS

When we start configuring the unit for the first time all the preload parameters have a default value, these values are stored in permanent memory but can be changed depending on the application of the unit.

The values can be changed from the display and the submenus require a password if you want to change the values; if an option is not included in the display menu the data is only an internal value in the controller and will be visible only if that mode is selected.

Set points for CLII Thermostatic equipment

The setting points mentioned below are intended to calibrate the equipment according to the requirements for tuning and observation of the work of the equipment.

High pressure reset time:

The purpose of this parameter is to reset the high pressure alarm for 180 seconds and then reset it.

Rest_HP 180s

Low pressure reset time:

The purpose of this parameter is to reset the low pressure alarm for 180 seconds and then reset it.

Rest_LP 180s

Set point low pressure transducer:

This parameter sets the set point at which the system can send an alarm when it detects low pressure in the system.

SP_Lowpres_Tras 2.7°C

Set point temperature by low pressure:

This parameter sets the set point at which the system can send an alarm when it detects low temperature due to low pressure.

SP_Lowpres_Temp 2.0°C

UNIT CONTROLLER OPERATION

Low pressure reset set point

This parameter indicates the parameter for which, after the system suffers a low pressure, it will be reset to the value dictated by this parameter.

Restore_SP_Suct 9.0°C

Set point temperature by ice water:

This parameter is intended to dictate the value at which the condenser water can reach the minimum temperature.

SP_Low_Out 4.5°C

Set point reset by ice water:

This parameter is intended to dictate the temperature at which the system will reset to temperature after suffering a chilled water alarm.

Restore_SP_Out 12.0°C

Condenser high temperature set point:

This parameter is intended to dictate the alarm at which the system may alarm for high condenser temperature.

SP_HTC 55.0°C

Condenser high temperature reset set point:

This parameter is intended to reset the high temperature alarm on the condenser.

Restore_SP_HTC 35.0°C

Calibration of the head water inlet temperature sensor:

From this parameter you can calibrate the general inlet water temperature sensor of the header by default the temperature for this sensor is 0.0 degrees.

Inlet 0.0°C

Calibration of the head water outlet temperature sensor:

From this parameter you can calibrate the general inlet and outlet water temperature sensor of the header by default the temperature for this sensor is 0.0 degrees.

Outlet 0.0°C

Suction temperature sensor calibration:

From this parameter the bulb suction temperature sensor can be calibrated.

SuctTempC1 0.0°C

Calibration of the suction pressure transducer sensor:

From this parameter the suction pressure transducer can be calibrated.

SuctPresC1 0.0bar

Calibration of the general water inlet temperature sensor:

From this parameter the general water inlet temperature sensor can be calibrated.

InletG 0.0°C

Calibration of the general water outlet temperature sensor:

From this parameter the general water inlet temperature sensor can be calibrated.

OutletG 0.0°C

High pressure switch signal status calibration:

From this parameter you can change the signal status of the pressure switch from normally open (N.O) to normally closed (N.C).

HP NO

Low pressure switch signal status calibration:

From this parameter you can change the signal status of the pressure switch from normally open (N.O) to normally closed (N.C).

LP NO

Evaporator flow sensor pressure switch signal status calibration:

From this parameter you can change the state of the water flow sensor signal from normally open (N.O) to normally closed (N.C).

FL NO

Pressure switch signal status calibration of the condenser flow sensor:

From this parameter you can change the state of the water flow sensor signal from normally open (N.O) to normally closed (N.C).

```
FL_C NO
```

Calibration of motor saver signal status:

From this parameter you can change the state of the motor device from normally open (N.O) to normally closed (N.C).

```
MS NC
```

Calibration of 4-way valve signal status.

From this parameter you can change the signal status of the 4-way valve from open (N.O) to normally closed (N.C).

```
4WV NC
```

Calibration of system flood valve signal status:

From this parameter you can change the state of the system flooding signal from (N.O) to normally closed (N.C).

```
Flood NC
```

Low pressure transducer enable calibration:

This parameter allows to enable or disable the low pressure transducer also allows to calibrate to the desired pressure in case it is required or the system needs to be leveled to an external reading.

```

Enable:Yes
C1 Range min: 0.0bar
   Range max: 45.0bar
  
```

SEQUENCE OF OPERATION

Figure 14. Sequence of operation of the CLII unit

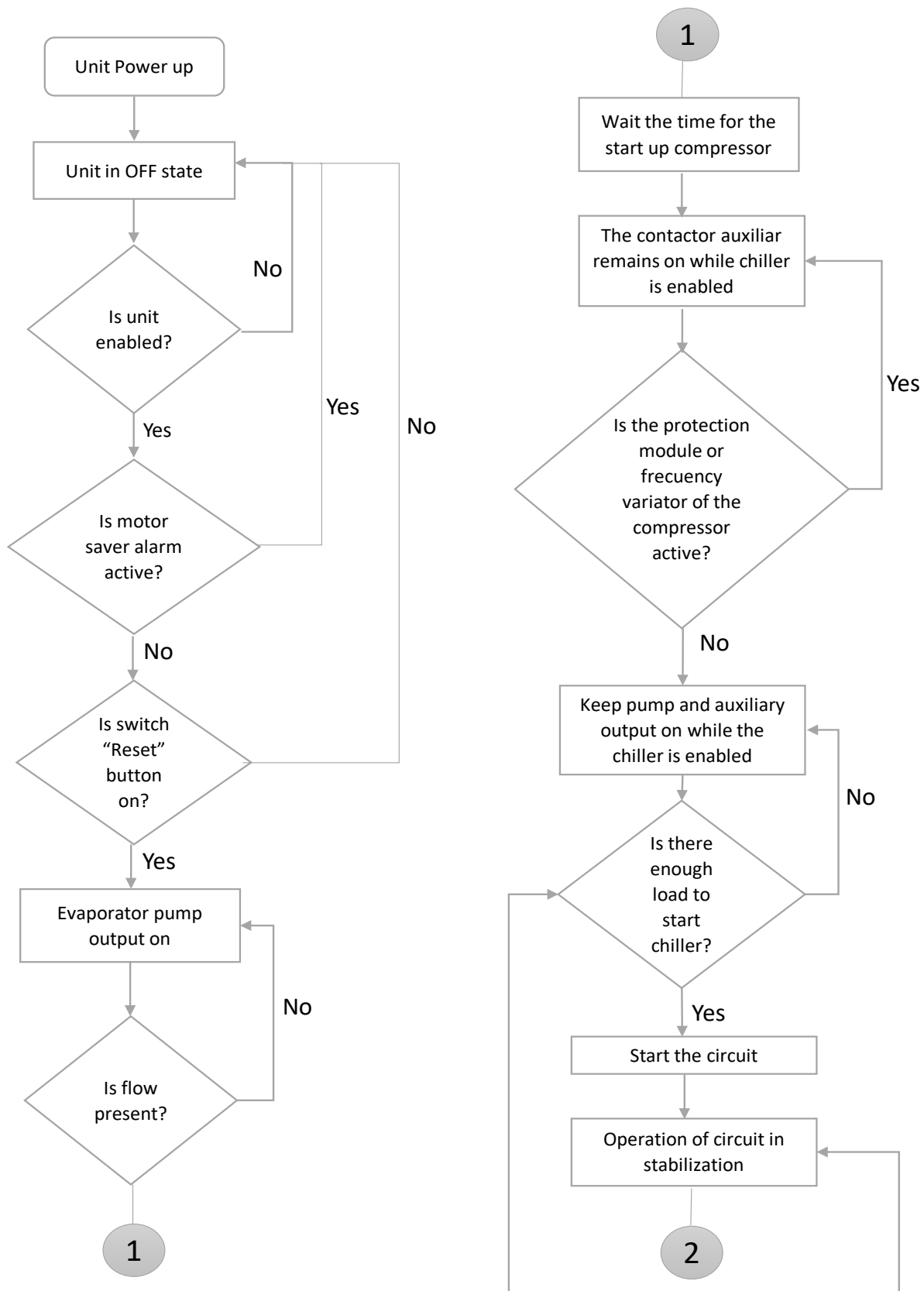

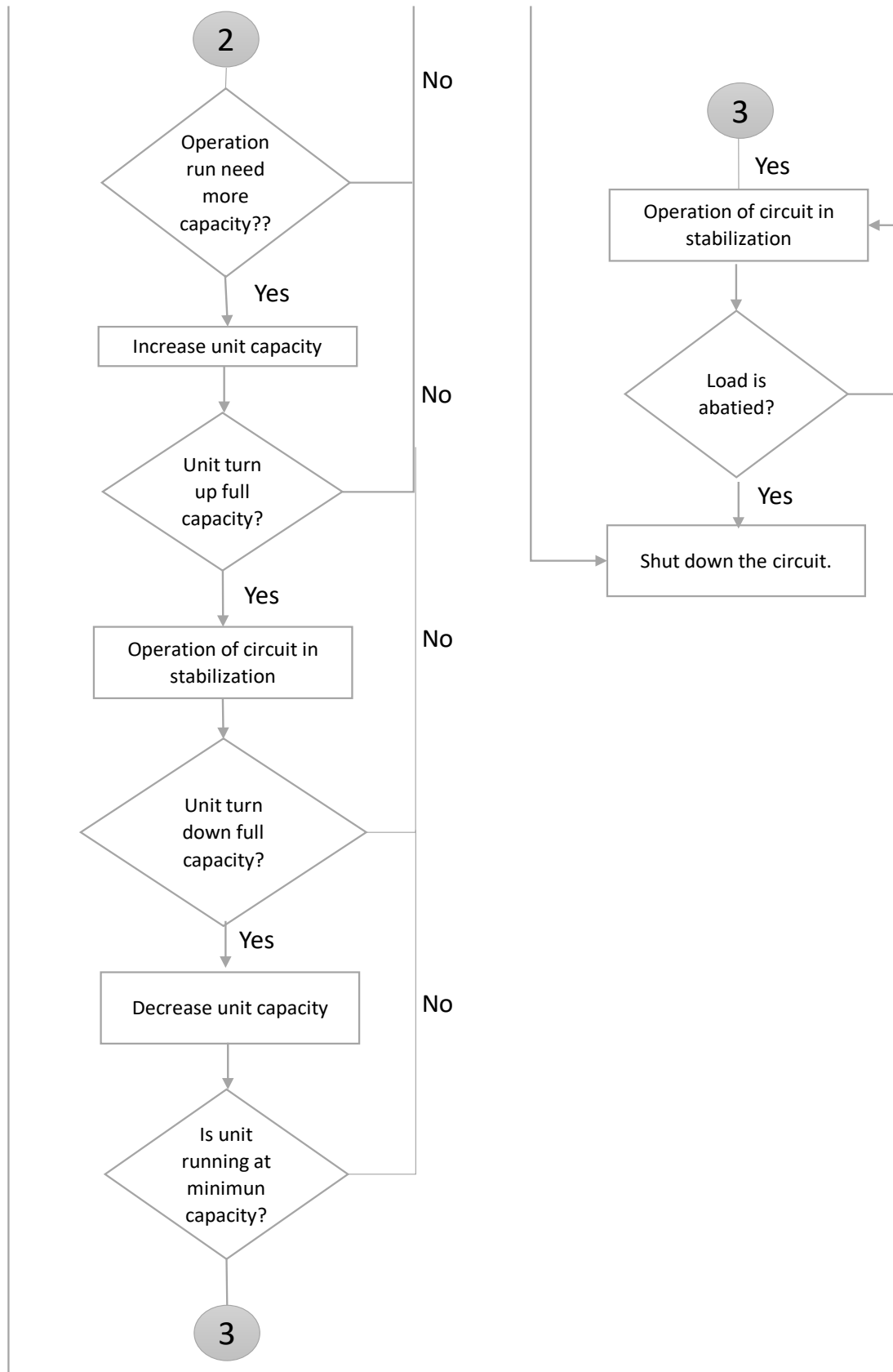

UNIT FUNCTIONS

The calculations in this section are used in unit-level control logic or all-circuit control logic.

EVAPORATOR DELTA T

The Delta T of the evaporator water is calculated as the temperature of the water entering minus the temperature of the water leaving through all the circuits.

PENDING LWT

The slope of LWT is calculated such that the slope represents the estimated change in LWT is immediately.

RATE OF DECLINE

The slope value calculated above will be a negative value as the water temperature is falling. The rate of decline is calculated by inverting the slope value and imitating it at a minimum value of 4°C/sec.

LWT ERROR

The LWT error is calculated as LWT - target LWT.

UNIT CAPACITY

Unit capacity is the Delta T of the unit operating for GPM of water.

Table 42. Minimum flow rates and corresponding maximum effective Delta T capacity with variable flow rate.

RT	"Number of compressors"	Capacity Unit	"Nominal Nominal (Nominal %)"	"Maximum effective full (°F) Capacity DT"
30	1	100%	100%	10.0
60	2	100%	96%	10.5
90	3	100%	92%	10.9
120	4	100%	88%	11.3
150	5	100%	85%	11.8
180	6	100%	81%	12.4
210	7	100%	77%	13.0
240	8	100%	73%	13.6
270	9	100%	70%	14.3
300	10	100%	63%	15.9

CONTROLLER CALCULATIONS

Refrigerant saturation temperature

The saturated coolant temperature will be calculated from the pressure sensor readings for each circuit.

Evaporator approach

The evaporator approximation will be calculated for each circuit. The equation is as follows
 Evaporator approximation = LWT - Evaporator saturated temperature.

Capacitor approach

The capacitor approximation will be calculated for each circuit. The equation is as follows
 Capacitor approximation = Capacitor saturated temperature - OAT.

Suction reheating

The suction superheat shall be calculated for each circuit using the following equation:
 Suction superheat = Suction temperature - Evaporator saturated temperature.

Pumping pressure

The pressure at which a circuit will pump down is based on the low pressure set point of the evaporator. The equation is as follows
 Pump down pressure = Evaporator low pressure set point - 103KPA (15 PSI)

CIRCUIT LOGIC CONTROL

Circuit enablement

A circuit must be enabled to start if the following conditions are met:

- The circuit breaker is closed
- No circuit alarms are active
- Circuit mode setpoint is set to Enable
- At least one compressor is enabled to start (according to the enable setpoints)

COMPRESSOR AVAILABILITY

A compressor is considered to be available to start if all of the following are met:

- The corresponding circuit is enabled.
- The corresponding circuit is not in pumping stop.
- No cycle timers are active for the compressor.
- The corresponding circuit is not in pump-down stop state -No cycle timers are active for the compressor.
- Compressor is enabled through the enable set points.
- Compressor is not running.

CIRCUIT STATES

The circuit will always be in one of four states:

Off - The circuit is not running.

Pre-open - The circuit is preparing to start up Running - The circuit is running

Pump off - The circuit is performing a normal shutdown.

The transitions between these states are shown in the diagram on the next page.

Figure 15. Circuit states.

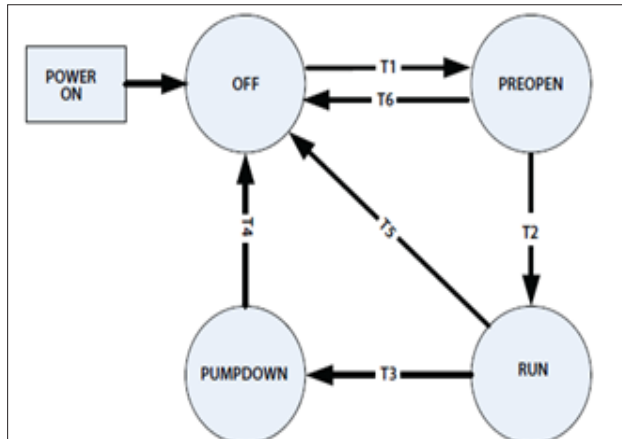

T1 –To pre-opening

- No compressor is running and any compressor in the circuit is commanded to start (see unit capacity control).

T2 – Pre-open to run

- 5 seconds have elapsed in pre-opening state

T3 – Running to pump down

Any of the following is required:

- Last compressor in the circuit is commanded to stop.
- Unit status = Pump stopped
- Circuit breaker is open
- Circuit mode is disabled
- Circuit breaker is open -Circuit mode is disabled -Pump down alarm is active

T4 - Pumping down on Off

Any of the following is required:

- Evaporator pressure < Pump downstream pressure value.
- Unit status = Off
- Unit status = Off -Quick circuit shutdown alarm active.

T5 - Run to Off

Any of the following is required:

- Unit status = Off
- Fast circuit shutdown alarm is active
- Low temperature start attempt failed

T6 Pre-open to Off

Any of the following is required:

- Unit status = Off
- Unit status = Pump off
- Circuit breaker is open
- Circuit mode is disabled
- Circuit quick stop alarm is active
- Pumping alarm is activated

COMPRESSOR CONTROL

Compressors should operate only when the circuit is in the operating or pumping state. They should not operate when the circuit is in any other state.

Compressor start-up

A compressor must start if it receives a start command from the unit capacity control logic.

Compressor shutdown

A compressor must be shut down if any of the following situations occur:

- The unit’s capacity control logic commands it to shut down.
- A discharge alarm occurs and sequencing requires this compressor to be the next compressor to shut down.
- The circuit status is pumping and sequencing requires this compressor to be the next compressor to shut down.

CONTROLLER CALCULATIONS

A minimum time between compressor starts and a minimum time between compressor stop and compressor start will apply. The time values are determined by the start timer and stop timer set points. These cycle timers should not be applied by power cycling the chiller. This means that if the power is cut off, the cycle timers should not be active. These timers can be cleared by a setting on the controller.

OVERHEATING CONTROL STATUS OPERATION

TXV Operation

The measurement of refrigerant flow to the evaporator is the exclusive function of a TXV. It must measure this flow at precisely the same rate at which the refrigerant is evaporated by the heat charge.

The TXV does this by maintaining the coil with enough refrigerant to maintain the correct superheat of the suction gas leaving the evaporator coil.

The TXV regulates the flow in response to the superheat of the charge.

If it is suspected that a TXV is not operating properly, checking for overheating is the only way to be sure. Do this with precision instrumentation to obtain meaningful results.

Operating overheat of 8°F to 12°F are considered normal. Below are some “tips” to help in detecting and fixing performance failures in a TXV:

- Check the bulb to make sure it is properly connected to the suction line. If you can move the bulb manually, it is not properly secured.
- The bulb must be perfectly insulated to protect against the effects of a draft.
- Check the equalizer line for restrictions (kinks) or signs of frost. A frosted equalizer line indicates internal leakage and will require valve replacement. Repair or replacement of a bent equalizer will be necessary for the valve to operate properly.

CIRCUIT FUNCTIONS

TXVs are designed to measure the flow of liquid refrigerant. If the refrigerant at the valve inlet contains flash gas, the capacity of the valve will be reduced. Make sure that the system is properly charged and that there is some subcooling at the valve inlet before discarding the TXV.



Dimensions (Mm)

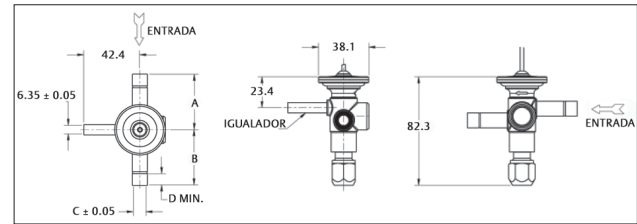

Adjustable - ODF connections with 1/4" equalizer

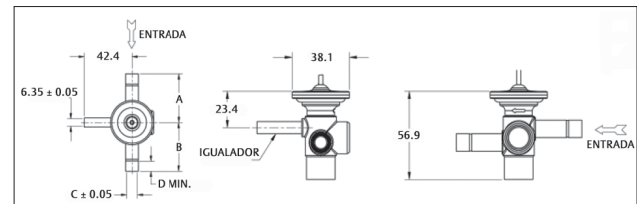

Non-adjustable - Odf connections with 1/4" equalizer

Connections	Dimensions			
	A	B	C	D
3/8 ODF	41.9	41.9	9.6 (3/8)	8.6
1/2 ODF	41.9	41.9	12.8 (1/2)	12.2
5/8 ODF	54.6	54.6	16.0 (5/8)	19.0
7/8 ODF	54.6	54.6	22.3 (7/8)	19.0
1-1/8 ODF	61.0	61.0	28.7 (1-1/8)	23.1

CLII THERMOSTATIC ALARMS







The alarms described below are intended to explain which are the most recurrent problems in the equipment. These alarms are the same in terms of the modules contained in the equipment.

ALARM	NAME	DESCRIPTION
MS_M	Motor saver alarm	Phase diagnostic device alarm: this device is located inside the panel and is responsible for checking that the AC voltage supplies are balanced and have no voltage rises or falls in case the device is alarmed it will send a signal which will be represented as a device alarm showing the legend MS_M on the controller.
HP_M	Refrigerant system high pressure switch	High pressure switch signal alarm on the refrigerant discharge line; this alarm is activated when the digital pressure switch on the refrigerant discharge line reaches the maximum pressure allowed by the device.
LP_M	Refrigerant system low pressure switch	Low pressure switch signal alarm on the refrigerant suction line; this alarm is activated when the digital pressure switch on the refrigerant suction line reaches the minimum pressure allowed by the device
Suction_M	Refrigerant system low pressure transducer	Coolant suction line pressure transducer analog signal alarm: this alarm is triggered when the analog pressure switch on the coolant suction line reaches the minimum pressure allowed by the device.
Outlet_M	Low evaporator water temperature	Low evaporator water temperature alarm; activated when the evaporator water outlet temperature probe detects temperatures outside the set limits.
Cont_Frez_M	Evaporator water low temperature count	This alarm indicates when the system has been reset more than 3 times by chilled water temperature; when the system is reset by evaporator outlet water temperature it starts working again in case the system has been reset more than 3 times this alarm will be activated.
Flood_Alarm_G	Flow alarm	This alarm will be active when the system detects flooding or water leakage in the system cannot be reset until this signal has been restored.
Flow_M	Evaporator flow alarm	This alarm will activate when the evaporator flow sensor is out of range; this alarm will not reset until the flow sensor is in range again.
Flow_Cond_M	Condenser flow alarm	This alarm will activate when the condenser flow sensor is out of range; this alarm will not reset until the flow sensor is within range again.
Hit_Cond	-	This alarm is present when there is a temperature outside the allowed range of high water temperature in the condenser.
Slv_M_Offline	-	When there is a communication problem with the slaves this alarm will be activated indicating the type of slave which is off line for this particular alarm means that the master's IO slave is deenergized or disconnected from the network.
Slv_1_1_Offline	-	When there is a communication problem with the slaves this alarm will be activated indicating the type of slave which is off line, for this alarm it means that slave 1 of address 1 is deenergized or off line.

CONTROLLER USE

CONTROL PANEL



BUTTON	DESCRIPTION	BACKLIGHT	SIGNIFICANCE
	Alarm	White / Red	Pressed together with Enter, accesses the screens managed by the operating system.
	Prg	White / Yellow	-
	Esc	White	Up one level
	Up	White	Increase value
	Enter	White	Confirm value
	Down	White	Decrease value

CONTROL PANEL INSPECTION

Check the control panel for foreign objects.

After completing the inspection of the installation points, and making sure that all elements of the unit are correct, the unit can be turned on.

- Energize the unit with electric power.
- Phase balance should be less than 2% on average.
- Turn on the water pump (if applicable), to make sure it is properly energized.

NOTE: Before powering up the unit, make sure that the control switches on each module are in the correct pre-start positions.

MOTHER UNIT	
Switch	Correct pre-start position
24 VAC	OFF (-)
System	ON (O)
Compressor 1	ON (O)
Compressor 2	ON (O)

CHILD UNITS	
Switch	Correct pre-start position
24 VAC	ON (O)
Compressor 1	ON (O)
Compressor 2	ON (O)

START UP

After turning on the equipment, wait 5 minutes for the unit to be ready for operation.

The operating sequence will begin by checking all pre-programmed safety points on the unit. If all required conditions are correct, the unit is ready to start operations.

24vac On / Control Bus Start:

To start operations, place the 24 VAC switch (FIG. 21) on the Mother Unit in the ON (-) position.

This will turn on the unit's digital control (control display). After a few seconds the unit can be turned on from the control screen.

Power On/Off:

Use the digital on/off control in the lower right corner of the control screen to turn the unit on and off (FIG.21).

COMPRESSORS

The COMPRESSOR 1 and COMPRESSOR 2 switches (FIG.21) allow the compressors to be switched on and off independently. If for any reason (maintenance, diagnostics, etc.) you wish to safely disable the operation of a compressor, you can do so using these switches.

SYSTEM

The SYSTEM switch enables the operation of the system logic. If you wish to return the equipment to its initial operating state, set the SYSTEM switch to the OFF position for 5 seconds and return it to the ON position.

OPERATION

If your unit is a Heat Pump, the OPERATION switch will allow you to set the operating mode between COOLING (cooling only mode) and HEAT PUMP (heat pump mode), select the desired operating mode.

NOTE: If your equipment is not a Heat Pump, the OPERATION switch will not be present on your equipment.

Figure 16. Cold only mode

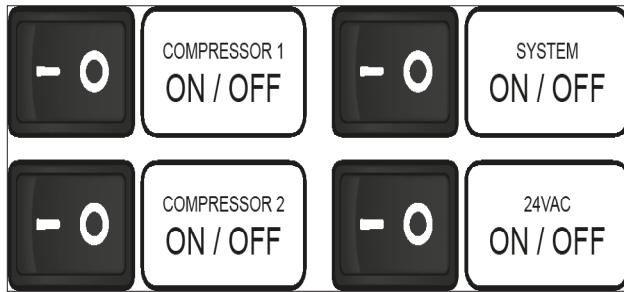

Start-up

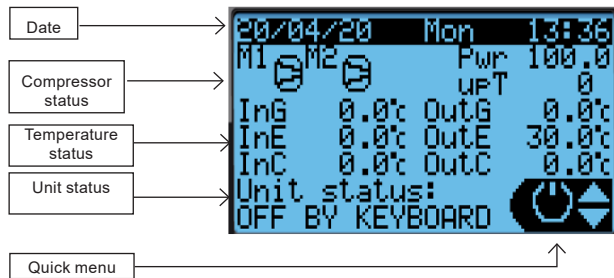

Date

Current date set.

Compressor status

Displays the current status of each compressor in the unit.

Temperature status

Displays the unit temperatures located in the unit.

- InG**= General Input (header)
- OutG**= General outlet (header)
- InE**= Evaporator inlet side (exchanger)
- OutE**= Evaporator outlet side (exchanger)
- InC**= Inlet side of condenser (exchanger)
- OutC**= Outlet condenser side (exchanger)

Unit status

Displays the current status of the unit (Off, On, etc.)

Quick menu

It is the quick access to a menu with essential information without password, to display the system configuration, information and current values for different types of units describing and configuring the system control.

QUICK MENU

On the home page this menu allows different submenus to configure and monitor the unit To select one by using $\uparrow\downarrow$ then pressing \leftarrow .

On / Off		Activate or deactivate the unit to start
Configuration		Configure the cooling and heating set point of the unit
Information		Display software information
Review		Show the value of the entries

On / Off

By $\uparrow\downarrow$ selecting an ON or OFF option, then back \rightarrow



Configuration

Press \leftarrow to move through the different options to change the set point, do not change the mode logic, this part is a critical setting.

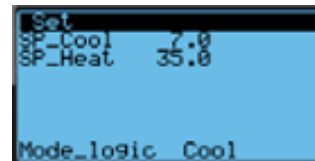

Information



Display the information about the software movement in the menu with $\uparrow\downarrow$



Review

Display the status of some variables on the functionality and operation, move in the menu with $\uparrow\downarrow$

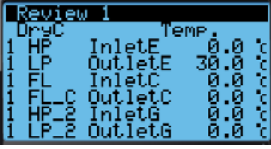
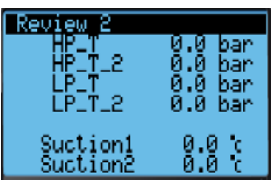
CONTROLLER USE

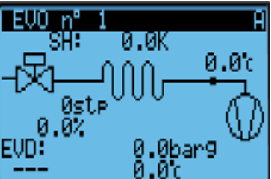
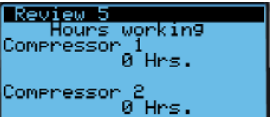
INPUTS	
	HP= High pressure switch status circuit 1
	LP= Low pressure switch 1 status circuit
	FL= Evaporator water flow switch FL_C= Condenser water flow switch
	FL_C= Condenser water flow switch
	HP_2= High pressure switch status circuit 2
	LP_2= Low pressure switch 2 status circuit
	InG= General inlet (header)
	OutG= General outlet (header)
	InE= Evaporator side inlet (exchanger)
	OutE= Evaporator side outlet (exchanger)
	InC= Inlet Condenser side (exchanger)
	OutC= Outlet condenser side (exchanger)
ELECTRONIC VALVE A (CIRCUIT 1)	
	Show valve information
	SH= superheat
	Suction temperature Opening percentage Suction pressure
ELECTRONIC VALVE B (CIRCUIT 2)	
	Display information about the valve
	SH= superheat
	Suction temperature Opening percentage Suction pressure
WORKING HOURS	
	Displays the working hours of each compressor

MENU

On the home page press **⊙** to go to the menu, and enter the correct password, change the value using **↑↓** and then press **←** to go to the next value until all digits are completed.

If you are successful move in the menu using **↑↓**

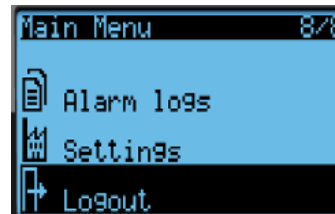
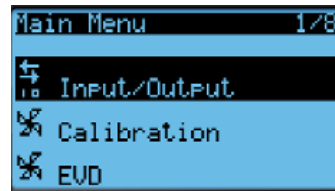
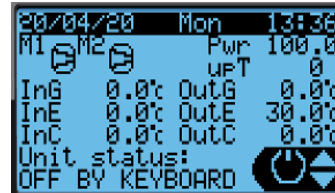

CONTROL EVD

Input / Output

Any information to show at this point (under construction)

Calibration

In this part you can change the status of the inputs and calibrate the probes. **↑↓** To move in the menu use to change any value press to **←** insert the correct value and press again to confirm. To exit press **↻**

	DIGITAL CALIBRATION INPUTS
	0= NO (normally open) 1=NC (normally closed)
	HP= High pressure switch status circuit 1
	LP= Low pressure switch status circuit 1
	FL= Evaporator water flow rate status
	FL_C= Condenser water flow rate status
	HP_2= High pressure switch status circuit 2
	LP_2= Low pressure switch status circuit 2
	MS= Electrical protection switch status
	Flood= Flood detector status
	ANALOG CALIBRATION INPUTS PLUS ONE ANALOG VALUE +/- (0,0)
	InG= General Input (header)
	OutG= General output (header)
	InE= Input Evaporator side (exchanger)
	OutE= Output Evaporator side (exchanger)
	InC= Inlet Condenser side (exchanger)
	OutC= Outlet condenser side (exchanger)
	DIGITAL CALIBRATION OUTPUT 0=NO (NORMALLY OPEN) 1=NC (NORMALLY CLOSED)
	4WV=four-way valve

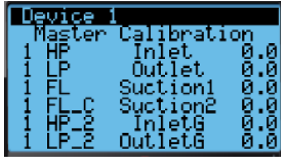

Displays all the information and variables to configure and calibrate the EVD (electronic expansion valve) controller to work efficiently for the unit, this is a critical configuration that could change the functionality of the unit. To move through the menu use **↑↓**

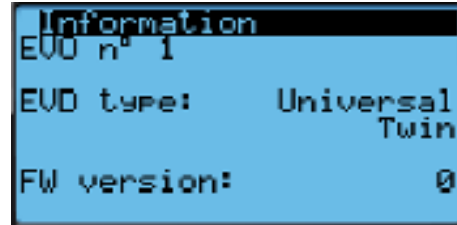

TANDEM CONFIGURATION

Set the rise time between steps, the down time before stopping any compressor, the type of chiller (heat or cold), the circuits and the steps, these settings cannot be changed by the user.

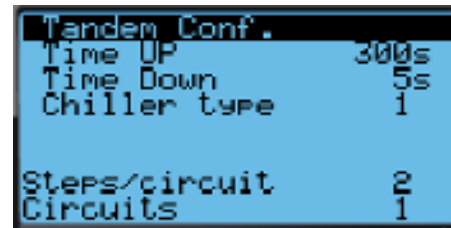

UNIT CONFIGURATION

Allows the option of exporting the import configuration and exporting the alarm logs.

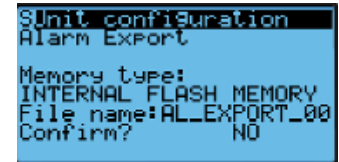

ALARM LOGS

Displays the entire alarm log at current time.

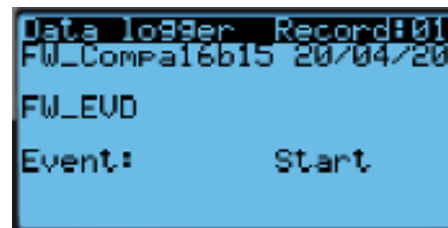

CONTROLLER USE

SETTINGS

Allows the option to configure date and time, units of measurement, language, serial ports, password and controller initialization.

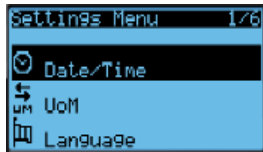

Date / Time

To change the current date, time and time zone

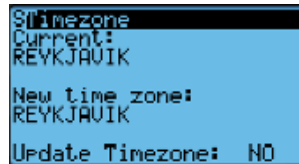
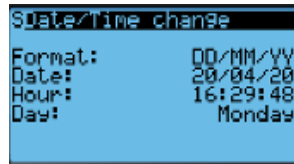

Unit of measure

Allows the option to change the type of unit of measure, American, International, and Press **←** to select and press again **←** to confirm. To exit press **↵**



Language

Allows the option to change the language, English, Spanish, Italian, etc.

Press **←** to select and press again **←** to confirm. To exit press **↵**

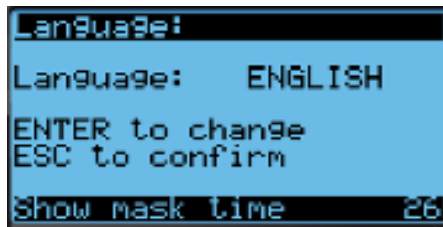

Serial ports

Allows the option to change the configuration of the ports, Modbus RTU, controller IP and PgdX if required.

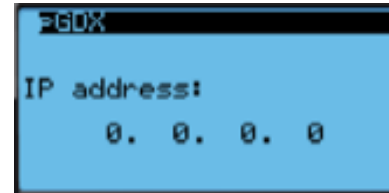
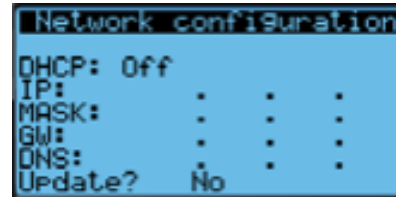
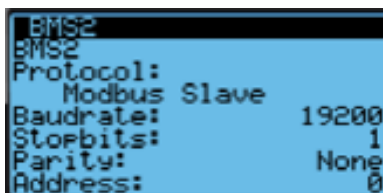

Password change

Allows the option to change the current passwords.

Press **←** to select and press again **←** to confirm. To exit press **↵**

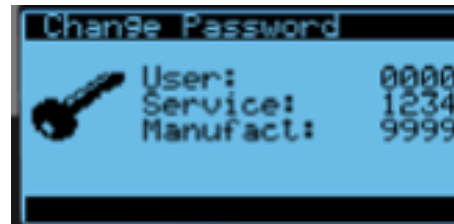

Initialization

It allows the option to change to the default configuration the register, the counters, enable or disable the buzzer and clear the memories. This configuration cannot be modified by the user.

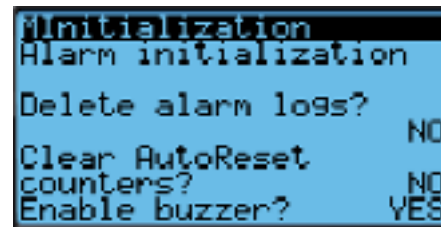

Logging out

Exit to the home page.

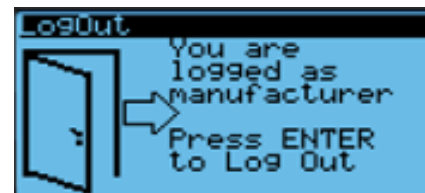

ALARMS

If there is an alarm, the following screen will appear when you press !△



At the moment of an alarm. The controller displays a red indicator on the alarm button. In this case it is necessary to press ! to see the present/current alarms activated.

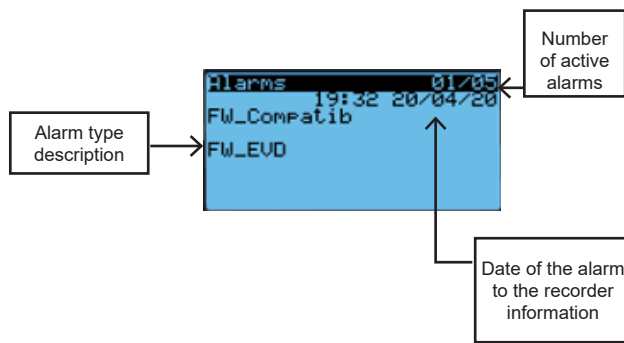

To reset one or all alarms, go to the end of the list on the next screen and press △ for 3 seconds.

NOTE: If the event that triggered the alarm is still present, it cannot be reset.



USER'S MANUAL FOR OPERATION OF CPCO EXPANSION CONTROL UNIT.

This manual is intended to explain the operation of the expansion control unit for CLII equipment in this brief manual will explain the screens and menus that the control has, this unit was added to include high pressure transducers and to display the values by modbus communication and through the control display.

As shown in Figure 2 the display of the control expansion unit has similar to the same features as the master control unit however this control expansion unit is only intended to display the values that has the high pressure transducers and display the values of the saturation temperature of the coolant.

Figure 17. Display CPCO



To select the display of the pressure transducers, simply access the menu at the bottom of the screen using the navigation buttons and select the option with the description TRS as shown in the following image.



Once the above menu has been selected, the legend corresponding to the description of the transducers will appear at the top, as shown below, along with the corresponding page number.



At the bottom of the menu you can see the transducer to which it is referenced and the unit from which the transducer is obtaining the reading as shown in figure 8; the nomenclature to which each transducer corresponds will be described below.

- HP TRANS M1: master circuit 1 high pressure transducer.
- HP TRANS M2: high pressure transducer of circuit 2 master.
- HP TRANS S1_1: high pressure transducer of circuit 1 slave 1.
- HP TRANS S1_2: high pressure transducer of circuit 2 slave 1.
- HP TRANS S2_1: high pressure transducer of circuit 1 slave 2.
- HP TRANS S2_2: high pressure transducer of circuit 2 slave 2.
- HP TRANS S3_1: high pressure transducer of circuit 1 slave 3.
- HP TRANS S3_2: high pressure transducer of circuit 2 slave 3.
- HP TRANS S4_1: high pressure transducer of circuit 1 slave 4.
- HP TRANS S4_2: high pressure transducer of circuit 2 slave 4.
- HP TRANS S5_1: high pressure transducer of circuit 1 slave 5.
- HP TRANS S5_2: high pressure transducer of circuit 2 slave 5.

CONTROLLER USE

Figure 18. Transducers

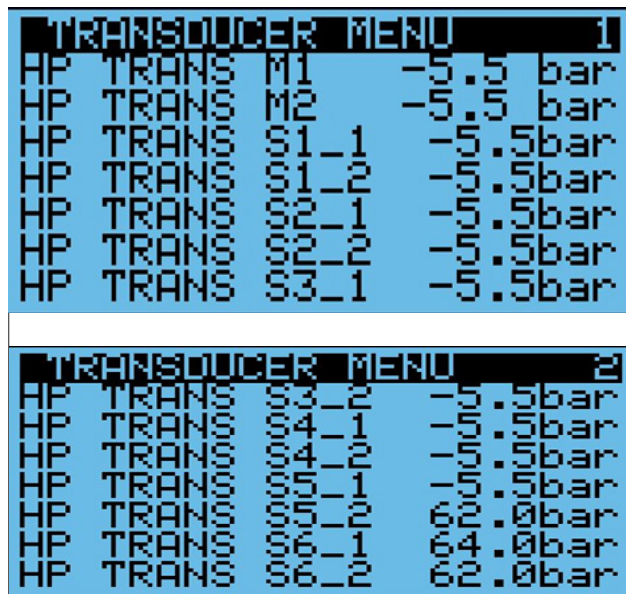

By continuing the navigation to the next page you will be able to access the coolant saturation temperature reading for each circuit.



PROCEDURE FOR CONFIGURING upC3 CONTROLLERS FOR CLII

The upc3 controllers that replace the c.pCOe expansion modules must each be configured via a PGD1 screen.

The controller type and serial address must be configured.

Two programs are available for this project, one exclusively for the main c.pCOMini controller and one for the upC3s. Once the program is installed on the upC3, the following screen will appear:

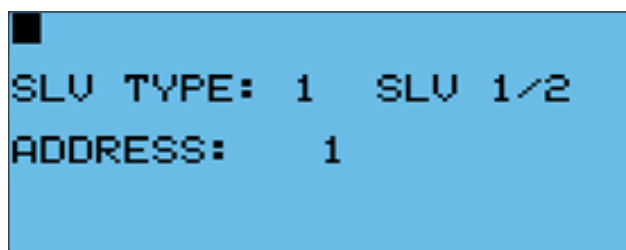

There are 3 types of configuration (upC3):

- SLV TYPE 1: (SLV 1/2) - Sets the controller as expansion module 1. (Ex. expansion 1 of Module 1).
- SLV TYPE 2: (SLV 2/2) - Sets the controller as expansion module 2. (e.g. expansion 2 of Module 1)
- SLV TYPE 3: (Main) - Sets the controller as expansion module of the main controller (c.pCOMini).

Depending on the selected slave type, the inputs and outputs will be configured.

Once the control type has been configured, the controller must be restarted for the changes to take effect correctly.

The address of the controllers should be as follows:

Module	Slave	Address
1	SLV 1	1
	SLV 2	2
2	SLV 3	3
	SLV 4	4
3	SLV 5	5
	SLV 6	6
4	SLV 7	7
	SLV 8	8
5	SLV 9	9
	SLV 10	10
6	SLV 11	11
	SLV 12	12
7	SLV 13	13
	SLV 14	14
8	SLV 15	15
	SLV 16	16
9	SLV 17	17
	SLV 18	18
Master	SLV M	20
	c.pCOMini	---

⚠ WARNING ⚠

The installer must take into account these procedures; his personnel must be qualified and certified to perform the installation, in order to comply with all specifications and good practices to ensure the correct operation of the unit.

PRE-START-UP CHECKLIST

The following data should be checked before putting the unit into operation.

Date:	
Place of Work:	
Location:	
Installing Contractor:	
Technician/Company:	
Unit Commissioning:	
Unit model:	
Serial number:	

PHYSICAL INSPECTION (BEFORE ELECTRICAL CONNECTION)

Check that the unit has not been damaged by handling or transport.	
Visually check for refrigerant leaks.	
Open the unit for hydraulic installation only. Do not remove the connection guards until the hydraulic circuit is closed.	

NOTE: Accessories such as thermometers, pressure gauges, measuring ports, etc., Are recommended but not necessary for the operation of the unit.

INSPECTION OF THE HYDRAULIC CIRCUIT

Date:	
Place of Work:	
Location:	
Installing Contractor:	
Technician/Company:	
Unit Commissioning:	
Unit model:	
Serial number:	

It is necessary to install a water filter in all hydraulic circuits to prevent the entry of solid particles, these must be installed on the return side of the circuit and must be cleaned once the initial system load is finished.

Check that the water filter is clean.	
Check that all service valves are open.	
Check the correct structure of the water supply.	
Check that all pipes are filled with water and that air has been evacuated.	
Check thermometers (not included from factory).	
Check the pressure gauges (not included in the delivery).	

⚠ WARNING ⚠

If the hydraulic circuit contains air, it may compromise the operation of the unit.

STARTUP AND SHUTDOWN PROCEDURES

CHECKING THE ELECTRICAL SOURCE

Units require model-specific electrical power with physical grounding, check the electrical specification on the nameplate of the equipment.

Verify that the circuit breaker is of the correct rating for the unit.	
Check that all electrical connections are secure.	
Check for false ground contacts as well as all wiring.	
Check internal control and power connections.	
Measure voltage on all units, ground, neutral and 3-phase line.	
Check that motor overload protection conforms to design requirements and is in automatic mode.	
Check voltage (*Motor save), which is set to supply the correct supply voltage for the unit.	

* The percentage of unbalance of the power supply must be calculated with the following formula, and adjusted with the UNBALANCE command.

$$\text{UNBALANCE PERCENTAGE} = \frac{[(\text{MAXIMUM AVERAGE DEVIATION}) / (\text{AVERAGE})] \times 100}{100}$$

DIAGNOSTIC LIGHT INDICATORS (LED STATUS)	
Regular operation	Evergreen
Delayed start	Flashing green
Reverse phase	Flashing red
Phase unbalance	Red in lapses
High/low voltage	Constant red

NOTE: The control panel of the unit has a ventilation duct, and must not be obstructed in any way.

NOTE: The units are factory set, however the power supply may vary in each installation and due to this imbalance must be adjusted before starting up the system in order to protect the motors and electrical components of all units.

INSPECTION OF THE CONTROL PANEL

Check that the control panel is free of foreign objects.	
Power supply unit with three-phase electrical current.	
The unbalance phase should be less than 2% of the average.	
Turn on the water pump (if applicable) to make sure it is running.	

After completing the inspection of the above installation points and ensuring that all elements of the unit are correct, the unit can be powered up. Turn the switch on the CONTROL UNIT to the ON position to power the control unit with 24 volts.

START-UP

After powering up the controller, wait 5 minutes for the unit to be ready to operate.

The operating sequence will begin by checking all pre-programmed safety points on the unit. If all required conditions are correct, the unit will be ready to start operations.

UNIT CONTROL

To start operations, turn the ON/OFF switch to the ON position. After 6 seconds, the control will command the pump to start. If water flow is detected in the piping, the internal sequence of the unit will start.

NOTE: After completing the inspection of the above installation points and making sure that all elements of the unit are correct, the unit can be turned on. Place the switch on the CONTROL UNIT in the ON position to power the control panel with 24 volts.

MAINTENANCE

Routine checks and maintenance should be performed during initial operation as well as periodically during start-up. These include verification of liquid lines, condensation and suction pressure measurements, as well as checking the unit for normal overheating and undercooling. A maintenance schedule is recommended at the end of this section.

Service or maintenance of this equipment should be performed by experienced personnel with specific refrigeration training. Safety devices should be checked repeatedly and cycling control components should be analyzed and corrected before resetting is initiated.

The simplified design of the refrigeration circuit totally eliminates potential problems during regular operation of the unit. No maintenance is required on the refrigeration circuit as long as the unit is operated on a regular basis.

Ease of maintenance has been considered during the design phase; thus, the unit is easily accessible for service and maintenance. By accessing the panels located on the front and side of the unit, service and maintenance of the unit can be performed easily.

The electrical components are located in the terminal box on the front panel, which allows easy access to them.

When the environment is constantly invaded with grease or dust particles, the coils should be cleaned by an air conditioning service technician on a regular basis to ensure that the cooling capacity is adequate and therefore the efficient operation of the equipment. The regular life span of the unit can be shortened if proper service is not performed.

For consistent durability and performance of the unit, proper maintenance should always be performed on a regular basis.

During extended periods of operation, the heat exchanger will become fouled, impairing the effectiveness and reducing the units performance. Consult your local supplier regarding cleaning.

The internal water circuit does not require major maintenance or service, except for water pump failure (if applicable). It is recommended that the water filter be checked regularly and replaced if it is dirty or clogged.

Always check the water level in the system to protect the moving components in the hydraulic kit from overheating and excessive wear.

NOTE: The manufacturer is not responsible for the malfunction of the unit if the main cause is lack of maintenance or the operating conditions of the unit do not correspond to those recommended in this manual.

COMPRESSOR MAINTENANCE

The internal pressure and surface temperature of the compressor are hazards and can cause permanent injury.

Operators, installers and maintenance personnel require proper skills and tools.

Tube temperatures can exceed 100°C and cause severe burns. Perform periodic service inspections to ensure system reliability. To avoid system-related compressor problems, periodic maintenance is recommended:

- Clean the compressor housing, make sure it is free of debris and dirt.
- Check the electrical/power connection between the unit and the compressor, make sure the power cable is tight and that there is no debris of any kind between the connections.
- Check the oil level and color in the oil sight glass (NOTE: Not all compressor models have sight glass).
- Inspect and verify compressor suspension brackets, they should not be cracked or broken.
- Verify that safety devices are operational and properly set.
- Make sure the system is airtight.
- Check the compressor current consumption.
- Confirm that the system is operating in a consistent manner, review previous maintenance records and environmental conditions.
- Verify that all electrical connections are properly tightened.
- Keep the compressor clean and verify the absence of rust and oxidation on the compressor, frame, tubing and electrical connections.

ELECTRICAL TERMINALS

Electrical connections should be inspected and tightened if necessary. Heat and vibrations can cause the connections to loosen, thus causing arcing.

For servicing electrical components:

- Disconnect main power lines before repairing or replacing any component or cable.
- Tighten all wire connections connected to the terminal block and/or components.
- Check connectors, wires and/or components for burn marks, worn wires, etc. If any of these conditions are present, they should be repaired or replaced immediately.
- The voltage on the equipment should be checked with a meter periodically to ensure adequate power supply.

NOTE: Each unit is packaged with complete wiring. Have diagrams available when making connections. The electrical connections required at the time of installation are: Supply power line to the power inlet and control wiring for and the control wiring for the remote control.

⚠ WARNING ⚠

Do not wire the control with high voltage wires. High voltage may interfere with control signals and/or may cause erratic or low performance.

⚠ WARNING ⚠

Risk of electric shock, can cause injury and death. Disconnect all sources of electrical power when working inside the unit. Potentially lethal voltages exist within the equipment during operation. Review all cautions and warnings contained in this manual. Only qualified personnel should service this unit.

UNIT MAINTENANCE

⚠ WARNING ⚠

Dust, dirt and debris should be removed regularly to avoid accumulation that will hinder the regular operation of the unit.

FILTER DRIER

Any particles or debris in the cooling circuit are swept by the coolant into the coolant line and trapped by the filter drier.

It is recommended that the filter drier be replaced whenever any repairs are made to the cooling line.

EXPANSION VALVE

The function of the expansion valve is to maintain an adequate supply of refrigerant to the Heat Exchanger/Evaporator. This is in order to satisfy the charge conditions.

Before adjusting the superheat, check that the unit charge is correct and that the liquid line is completely full and bubble free, and that the circuit is operating under stable load conditions.

The suction superheat for the suction discharge of the heat exchanger/evaporator is factory set for 10° F.

⚠ WARNING ⚠

Risk of explosive discharge of refrigerant at high pressure. This can cause personal injury or equipment damage. Never loosen any connections on refrigerant or electrical lines until the compressor has been depressurized on both sides.

ANNUAL MAINTENANCE SCHEDULE

Before performing any work on the unit, make sure that you have the proper Personal Safety Equipment (PPE) and that the unit is turned off and at rest.

It is recommended to energize the unit 6 hours* before the first start-up to warm up the compressor oil.

NOTE: If a component change or repair has been made to the refrigeration circuit, it is recommended that the filter drier be changed.

*Depending on conditions, you may wish to energize the unit longer in advance.

HYDRAULIC CIRCUIT MAINTENANCE

- **Hydraulic Filter:** Inspection, cleaning, replacement if necessary. Monthly
- **Hydraulic Circuit:** Inspection for leaks and corrosion in piping, welds, joints and other components. Monthly
- **Hydraulic Circuit:** Replacement of water in the circuit. Quarterly

REFRIGERATION CIRCUIT MAINTENANCE

- **Compressor:** Compressor and compressor oil inspection. Monthly
- **Filter Drier:** Inspection and replacement if necessary. Monthly
- **Cooling Circuit:** Inspection for leaks and corrosion in piping, welds, joints and other components. Monthly
- **Refrigeration Circuit:** Check refrigerant pressure. Quarterly

ELECTRICAL MAINTENANCE

- **Electrical Components:** Tighten connectors and terminals on electrical panel, control parts, power and junction boxes. Quarterly
- **Electrical Panel:** General cleaning, remove dirt and foreign objects. Monthly
- **Electrical Panel:** Physical inspection of all connectors, components and relays. Monthly
- **Electric Motors:** Review amperage of all electric motors and compare them according to the equipment nameplate to detect abnormalities. Quarterly
- **Electrical Connections:** Physically inspect for false contacts, corrosion or burns. Monthly
- **Electrical Protections:** Verify the adjustment and condition of electrical protections and fuses; these must be in accordance with the manufacturer's specifications. Bimonthly

PHYSICAL INSPECTION

- **Structure: General** overhaul and cleaning. Bimonthly
- **Energy:** Review and compare the unit's energy consumption with previous months to detect any anomalies in performance.
- **Control:** Check alarm history. Monthly
- **Drain Line*:** Check that it is not clogged and that water is flowing properly. Monthly

It may not be on your computer.

NOTE: If any component has been replaced or the cooling circuit has been repaired, it is recommended to change the filter drier.

TROUBLESHOOTING CHART

When a fault is detected in the unit, it is necessary to completely shut down the equipment before proceeding with any of the procedures listed here.

The following tips are suggestions for resolving common equipment faults. If a fault occurs that is not listed here, please contact your nearest distributor. Under no circumstances should you attempt to solve the problem yourself.

Problem	Possible causes	Possible corrective actions
Compressor does not run.	Main or compressor disconnect switch open.	Circuit breaker closed.
	Damaged fuse, open circuit brakes.	Check the electrical circuit and possible short circuit, line to ground, loss of connections or motor windings causing the failure. Replace the fuse and reset the compressor brakes, only after detecting and correcting the cause of the fault.
	Thermal overloads have tripped.	Overloads are self-resetting. Check supply voltage, operating amps, cycle times and mechanical operations. Allow time for automatic reset.
	Faulty contactor or coil.	Replace.
	System shutdown by equipment protection devices.	Determine the type and cause of the shutdown and correct it before restarting the equipment. For example, low or high pressure, water freezing, etc.
	No cooling required.	Wait until the unit calls for cooling.
	Liquid line solenoid does not open.	Repair or replace the solenoid. Check wiring.
	Motor electrical problems.	Check for open, shorted or bubbled motor.
Compressor makes noise or vibrates	Loose wiring.	Check all wire connections and tighten all terminal screws.
	Compressor running in reverse.	Check that the unit and compressor are on the correct phase of the line voltage.
	Inadequate piping or supports on suction or discharge.	Reposition, add or remove hangers.
	Worn compressor insulator bushing.	Replace.
	Compressor mechanical failure.	Check for possible problem in compressor failure and replace.
High Pressure / High Pressure Alarm.	Low oil level.	Check the possible problem before it damages the compressor.
	Non-condensable gases in the system.	Remove non-condensable gases / Replace refrigerant charge.
	Circuit overloaded with refrigerant.	Remove excess refrigerant.
	Optional discharge off, valve not open.	Open valve.
	On.	Check and correct electrical connection.
Condenser coil dirty, clogged.	Clean and/or clear coil of obstructions.	

TROUBLESHOOTING CHART

Problem	Possible causes	Possible corrective actions
Low Pressure / Low Pressure Alarm.	Rapid load changes in the system.	Stabilize the system.
	Refrigerant leakage.	Check for refrigerant leaks, repair and add refrigerant.
	Lack of refrigerant.	Add refrigerant according to normal charging process.
	Dirty filter drier.	Check the pressure drop across the filter drier. Replace filter if necessary.
	Expansion valve malfunction.	Adjust, Repair or Replace expansion valve. Adjust for proper superheat.
	Condensing temperature too low.	Outside temperature below design parameters.
	Compressor does not start properly.	Check corrective steps.
	Compressor start intervals too long low / slow.	If system has excess oil, recover and adjust by observing liquid sight glass on compressor.
	Insufficient water flow.	Correct the water flow to the minimum required by the system.
	Excess oil or use of wrong oil in Compressor.	Remove and/or change compressor oil.
	Dirty heat exchanger.	Check the pressure drop across the heat exchanger. Clean or replace if necessary.
Compressor thermal protection switch open.	High condenser temperature.	See corrective steps for high discharge pressure.
	System operating beyond design conditions.	Correct conditions to be within system design limits.
	Discharge valve not open.	Open discharge valve.
	Cycling too fast.	Stabilize load or control settings. Allow time for system to stabilize.
	Incorrect voltage range or unbalance.	Check and correct.
Compressor oil level too high or too low.	Overheating in electrical connections.	Verify that components have proper thermal protection ratings for the system. Replace if necessary.
	Coolant / oil leakage.	Inspect the cooling system for leaks. Correct and recharge coolant.
	Low oil level.	Check overheat temperature, add oil.
	Oil line loose / improperly tightened.	Inspect, check, adjust or replace oil line.
	Oil level too high with compressor operating.	Check overheat temperature, remove oil.
	Insufficient water flow. Oil level too high.	Correct water flow. Check overheat temperature.
	Excessive liquid in crankcase. Too high oil level.	Check crankcase heater. Check solenoid valve fluid line operation.
	Short cycling.	Stabilize load or correct control settings for application.
	Compressor mechanical failure.	Inspect and replace compressor if necessary.
Incorrect oil type.	Check oil type. Replace if necessary.	

Problem	Possible causes	Possible corrective actions
Motor relay overload or circuit breakers open.	Improper voltage.	Check voltage and correct.
	Voltage unbalance or out of range.	Check and adjust voltage balancing.
	Faulty motor wiring or grounding.	Inspect and if necessary replace compressor.
	Loose power wiring or burned connectors.	Check all connections and tighten them, replace connectors.
The unit does not turn on.	High condenser temperature.	Check correction steps for high condenser pressure.
	Equipment does not have enough refrigerant.	Check data sheet and check system for leaks.
	High condensing temperature.	Check condenser and repair.
	Equipment does not have sufficient water flow.	Check technical data, check filter in water line and adjust flow if necessary.
	Inadequate voltage.	Check voltage and correct it.
	No water flow in the system.	Check for proper water flow to the system.
	Presence of air bubbles in the system.	Remove air from hydraulic circuit.
	Water flow is reversed.	Check and correct water flow / pumping.
	Error in electrical connection.	Verify electrical connection and presence of power on site.
The unit turns on but does not cool sufficiently.	Injection temperature value is incorrectly set.	Check and adjust injection temperature.
	Dirty / clogged condenser.	Clean / release condensers.
	Air suction and discharge is clogged.	Inspect, clean, clear, remove any possible obstructions or objects.
	Not enough refrigerant in the system.	Check refrigerant circuit pressures. If necessary add refrigerant to the system.
	Insufficient water flow in the system.	Verify that the water flow meets the minimum required by the system. Correct water flow / flow rate.
	Water in the system is dirty or with residue.	Drain dirty or debris water and replace with clean water.
Water pump will not start	No electrical power.	Check electrical connection (False contacts) and correct.
	Pump damaged.	Inspect and replace if necessary.
	Pumping system.	Check the operation and configuration of the pumping system.

THIS PAGE IS LEFT INTENTIONALLY IN BLANK

