



Air Conditioning



Cliv serie
axial

TECHNICAL DATA MANUAL

We are leaders in the creation of innovative air conditioning solutions using state of the art technology and world class product design



SMALL FOOTPRINT

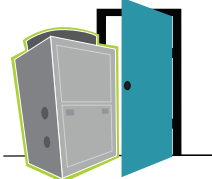

BALANCING VALVE

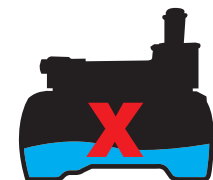

ISOLATION VALVE

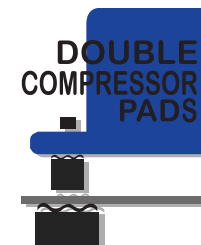

DOUBLE COMPRESSOR PADS



MICROCHANNEL

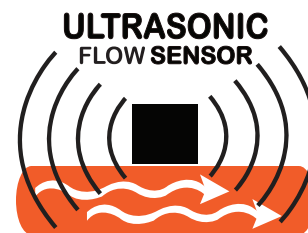

ULTRASONIC FLOW SENSOR



EC FANS

COMFORT FLEX | TECHNOLOGIES

This technology may or may not be included in the unit depending on the model

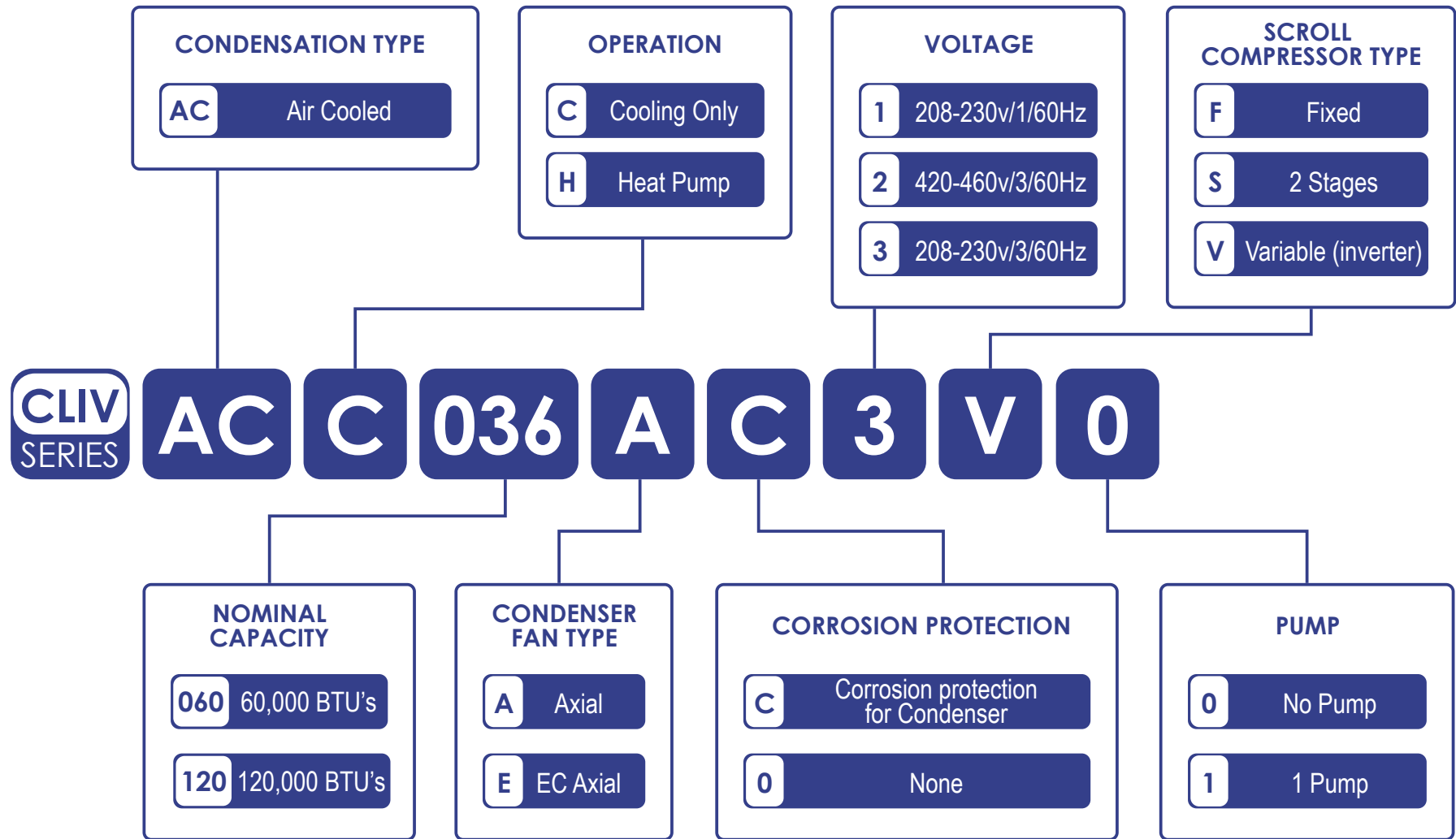

WARNING - CAUTION - NOTE

IMPORTANT SAFETY INSTRUCTIONS

This manual contains important safety instructions that should be followed during the installation and maintenance of the unit. Read this manual thoroughly before attempting to install or operate this unit.

Only qualified personnel should service this equipment. Adhere to all warnings, cautions, operating and safety instructions on the unit placards and in this manual. Follow all operating and user instructions during and after installation.

Installer should pay particular attention to the words: **NOTE**, **CAUTION** and **WARNING**. Notes are intended to clarify or make the installation easier. Cautions are given to prevent equipment damage. Warnings are given to alert installer that personal injury and/or equipment damage may result if installation procedure is not handled properly.



Improper installation may create a condition where the operation of the product could cause personal injury or property damage. Improper installation, adjustment, alteration, service, or maintenance can cause injury or property damage. Refer to this manual for assistance or additional information, consult a qualified installer or service agency.
Electrical shock hazard. Disconnect voltage at main panel or power source before opening any cover. Failure to comply may result in injury or death.
To minimize the hazard of electrical shock and personal injury, this component must be effectively grounded. Refer to installation guidelines for further information.



This product must be installed in strict compliance with the enclosed installation instructions and any applicable local, state, and national codes including but not limited to, building, electrical and mechanical codes.
Risk of sharp edges, splinters, and exposed fasteners. Can cause injury.
Only properly trained and qualified personnel wearing appropriate safety headgear, gloves, shoes and glasses should attempt to move the unit, lift it, remove packaging or prepare the unit for installation.
Risk of contact with hot surfaces. Can cause injury.
The compressors, fan motors, refrigerant discharge lines and reheats are extremely hot during unit operation. Allow sufficient time for them to cool before working within the unit cabinet.
Periodically inspect all valves, fittings, and piping for corrosion, rust, leaks, or damage.
This unit uses a microprocessor-based electronic control system. Do not use jumpers or other tools to short out components, or to bypass or otherwise depart from recommended procedures. Any short-ground of the control board or accompanying wiring may destroy the electronic modules or electrical components.

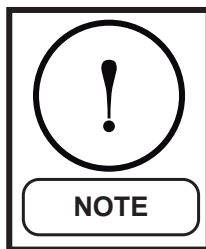

Risk of clogged or leaking drain lines. Can cause equipment and building damage. This unit requires a water drain connection. Drain lines must be inspected regularly and maintenance must be performed to ensure that drain water runs freely through the drain system and that lines are clear and free of obstructions and in good condition with no visible sign of damage or leaks.
This unit may also require an external water supply to operate.
Improper installation, application and service practices can result in water leakage from the unit. Water leakage can result in severe property damage and loss of critical equipment. Do not locate unit directly above any equipment that could sustain water damage.

• Efficiency

Our units are designed to meet the needs of any project. Our featured intelligent process controllers and smart temperature sensors provide maximum performance while saving energy.

The system automatically modifies the operation mode to maintain optimal conditions, making it very easy to operate.

All temperature sensors are calibrated and set at the factory before shipment. Start up has to be performed by a qualified technician, during the initial startup steps the unit will be set to local conditions and all points of operation will be reviewed.

Once the unit is set, operation is a matter of pressing the start and stop button and making sure that the unit operates properly, after this the unit will operate automatically, starting itself according to the demand of the cooling system and local conditions.

• Flexibility

The units have smart processors and sensors to automatically control the temperature at optimum operating conditions.

The units were designed to mate with each other and be combined to meet different load variations (tandem installation). You can combine up to 8 modules; these combinations may be done with chillers of different capacities ranging from 3 to 200 tons. Capacity varies depending on the number and type of units.

• Reliability

All structures are made of galvanized steel sheet, coated with electrostatic baked paint to ensure long durability and no corrosion in any weather, such as prolonged direct sunlight, rain and wind.

All units are designed to fit a reduced installation space, eliminating thus large installation areas. We only use high quality components to ensure durability and reliability even under harsh environmental conditions.

NOTE: For applications in tropical climates our units are coated inside and outside with Corrosion Protection.

Our products have efficiency certifications from AHRI and electrical certifications from ETL, we also comply with all industry safety standards. We are members of the American Society of Air Conditioning, Refrigeration and Heating Engineers (ASHRAE). To support our commitment to customers and our stakeholders our units have a 1 year mayor warranty after start up, .

Our units use R410A refrigerant, which is harmless to the ozone layer and is not toxic or flammable, even in case of leakage.

Finally, the heat exchanger efficiency and modular design allow for an easy and quick installation.

• Design

Research conducted by the Engineering Department have resulted in units with a high design efficiency and optimum performance. The selection of prime components and our quality and control system ensures performance and reliability. All main components are rigorously tested and qualified before being installed. Each unit design has gone through long hours of rigorous testing to ensure reliability, durability and quality of the entire system.

All external paint has been tested in a saline chamber and is rated at 1,500 hours proof. Compressors and heat exchangers ensure high equipment efficiency capacity. The water pump is specially designed to work properly and with minimal vibration and noise.

All units have a compact and sturdy structure while maintaining a slim profile.

• Communication

The units can be controlled independently as a single unit (individual mode), or they can be connected to a central control unit ("Tandem Mode"). Operation and user input is done via a color 7" touch screen.

Our units can handle different communication protocols; such as Modbus and Bacnet, the most commonly used protocols in the HVAC industry.

Our units keep track of all the programming variables in real time, as well as monitoring performance and specific alarms in the refrigeration cycle, the electrical system as well as external factors such as fire and flood detection (optional sensors).

The control and monitoring system ensures the proper operation of the unit by monitoring in real time the health of all mayor components (high and low refrigerant pressure, compressors and fan motors health, etc).

In case of a malfunction the event will be recorded for later analysis, facilitating the location of the possible failure and its solution.

• Installation

The units have been designed for a field-friendly installation. Screw type connections provide easy installation of the water pipes, said connections are located on both sides of the unit, so that the pipes can be connected on either side of the equipment.

The individual assembly of the units reduces installation costs on site, the units have a rigid base which bears the weight of the unit and allows an easy installation.

• Maintenance

The simplicity in the design of each unit allows maximum ease in maintenance. All mayor components are available to maintenance personnel by opening the service panel. If an emergency stop occurs, the control section will indicate the detailed cause of the failure, helping to accelerate and facilitate the solution process.

• Factory Testing

Each unit is pressure and vaccum tested, then charged with the refrigerant required for proper operation based on the client installation conditions.

The units are then evaluated at full load operation with water flow, thermal load and line voltage set to the actual conditions in which the equipment will operate. Finally the units are performance tested at application temperatures ranging from -10 °C to 45+ °C.

NOTE: The warranty policy requires that the start up be made by qualified and authorized personnel.

Units are built with control and design in mind, assembled with technically specialized control software. Some of our features are in house production of all piping and wiring, scroll type compressors, new generation evaporators, air cooled condensers, optional hydraulic components, and several safety and security protections. Our units are ecofriendly and operate with R-410A refrigerant.

• Compressor

Our two-stage, fixed scroll, digital and variable compressors have better liquid handling properties. Because of its axial and radial shape, it allows parts of the scroll to be separated in the presence of coolant, thus offering protection against liquid damage.

They are more efficient over the full operating range, operating at sound levels and lower vibration than traditional compressors, it has 70% fewer moving parts, startability under any load on the system, without removing components, easy service and maintenance due to its compact size and lightweight and simple design, built to achieve optimum performance with current refrigerants without chlorine, without complex internal suction valves and discharge for quieter operation and increased reliability.

• Evaporator

The plate heat exchanger is made of stainless steel plates welded together closely to ensure high efficiency heat exchange. The heat exchanger is insulated with a flexible elastomer of a minimum thickness of 1/2" to provide optimal thermal insulation.

The microchannel technology allows to optimize the use of refrigerant, both in the condenser and throughout the cooling cycle. This is a series of flat tubes (microchannels), through which the refrigerant circulates. Heat transfer is maximized by these extremely thin tubes, optimizing the system, providing significant savings in the use of refrigerant gas.

• Thermostatic Expansion Valve

The Thermostatic Expansion Valve (TEV) keeps the evaporator stocked with sufficient refrigerant to meet load conditions. It has no way to turn on or off the compressor, but keeps the superheated refrigerant itself in the suction line of the compressor. The thermostatic expansion valve installed in each circuit has been selected for a range of specific operation conditions.

• Filter-Drier

The dehydrator filter is designed to keep the circuit clean and remove residual moisture from the refrigerant circuit and avoid affecting the operation of the unit by acidification of the oil, which causes slow disintegration of the varnish that protects the motor windings in the compressor.

• Fan

To carry out air injection the units have axial and centrifugal type fans, which are directly driven by single-phase and/or three-phase motors. The fans are weatherproof to ensure continuous operation.

• Expansion Tank (optional)

Used in the system to handle the volume variations of the liquid contained in the pipe system due to temperature changes.

• Balancing Valve

This balancing valve is placed in the unit in order to control and maintain a constant water flow in the circuit, with the special feature that the flow can be adjusted anytime as needed.

• Temperature Sensor

Through digital signals generated by these devices the temperature is measured accurately and in real time.

COMPONENTS

• Refrigeration controls

The units are equipped with solenoid valves, expansion valves, dehydrator, and service valves.

• Electrical components

All units are equipped with a control panel, security anti-theft devices, internal and external overheating protection, compressor drive protection, flow protection, freezing protection and electrical failure protection. The control panel has LED operation indicating lights. Depending on the model some other indicators may be installed.

HYDRAULIC COMPONENTS (OPTIONAL)

• Water pump

The drive in the water pump is TEFC (Totally Enclosed Fan Cooled) and has anti-corrosive coating on the housing.

CONTROL

The control unit allows the connection of the unit to the INTERNET, and allows the user to visualize all the unit's operating information, such as variable graphics, tendencies cycle time, diagnosis of components, alarms, etc. Access to this information renders a more efficient operation and system control.

CONNECTIVITY

The connectivity via internet enables our units to operate remotely, to check the status of their maintenance cycle and remedy any situation quickly and efficiently.

VRW

This units are pioneers in the VRW technology. The most important advantages are no loss of performance tonnes over distance, uses water as heat medium, requires no special installation, far better performance at a lower cost.

CORROSION PROTECTION (OPTIONAL)

The inorganic film on the surface is ultra thin and is formed by an inert ceramic glass layer that is obtained at ambient temperatures. This innovative technology provides:

- UV resistance
- A crystalline finished, non-yellowing
- Positively charged coating to repel H₂O
- Magnificent luster and depth of image retention
- Outstanding resistance to solvents and chemicals
- Exceptional abrasion resistance

• Energy Efficient

With Corrosion Protection you save energy between 9% to 15%. Its sealant layer of only 3-5 microns allows heat transfer be more efficient.

• Extends the life of the equipment

Corrosion Protection extends the life of your air conditioner units, refrigerators or cooling towers, because it protects up to for 5 years, preserving its appearance and function.

Corrosion Protection is applied to cabinets, capacitors, grids and coils, achieving great benefits and durability that can not be obtained with conventional protections.



• WATER PUMP (OPTIONAL)

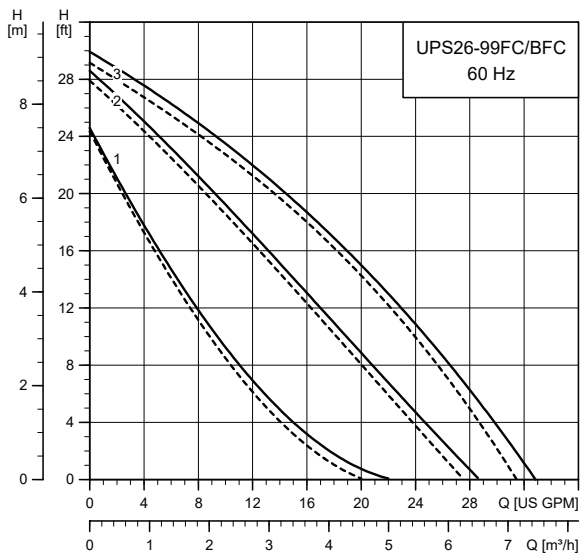

— Without check valve

- - - With check valve

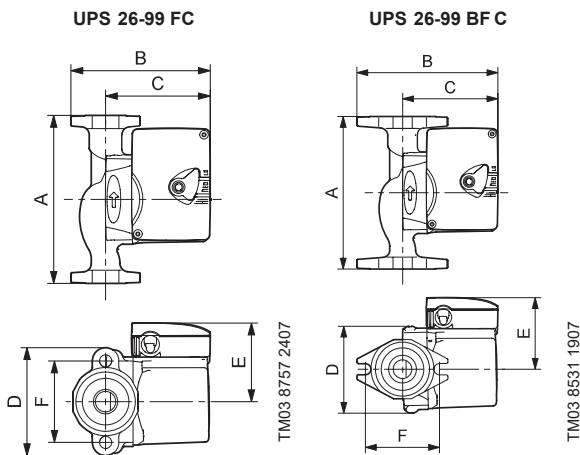

Technical Data

UPS 26-99 F/BFC

Flow range: 0-33 gpm (0-7.5 m³/h)
 Head range: 0-29 ft (0-8.8 m)
 Motors: 2-pole, single-phase
 Max. liquid temperature: 230 °F (110 °C)
 Min. liquid temperature: 36 °F (2 °C)
 Max. system pressure: 145 psi (10 bar)

Model	Speed	Volts	Amps	Watts	Hp	Capacitor
UPS 26-99 FC	3	115	1.8	197	1/6	20μF/180 V
	2		1.5	179	1/6	20μF/180 V
	1		1.3	150	1/6	20μF/180 V
UPS 26-99 FC/BFC	3	230	0.9	196	1/6	5μF/400 V
	2		0.8	179	1/6	5μF/400 V
	1		0.7	150	1/6	5μF/400 V

Model Type	Product Number		Dimensions [inches (mm)]						Connection Type and Size	Shipping Weight [lbs (kg)]
	115 V	230 V	A	B	C	D	E	F		
UPS 26-99 FC	52722512	52722513	6.50 (165)	6.00 (152)	4.88 (124)	3.50 (89)	3.44 (87)	3.16 (80)	GF 15/26 flange (2) 1/2" dia. bolt holes	10.3 (4.7)
UPS 26-99 BFC	52722518	52722519	6.50 (165)	6.00 (152)	4.88 (124)	3.50 (89)	3.44 (87)	3.16 (80)	GF 15/26 flange (2) 1/2" dia. bolt holes	10.3 (4.7)

Approvals

UP 26-99 F/BFC

UP 26-99 BFC



The check valve can be removed.
 Dimensions in inches unless otherwise noted.

• WATER PUMP (OPTIONAL)

Technical Data

UPS 26-150 F/SF

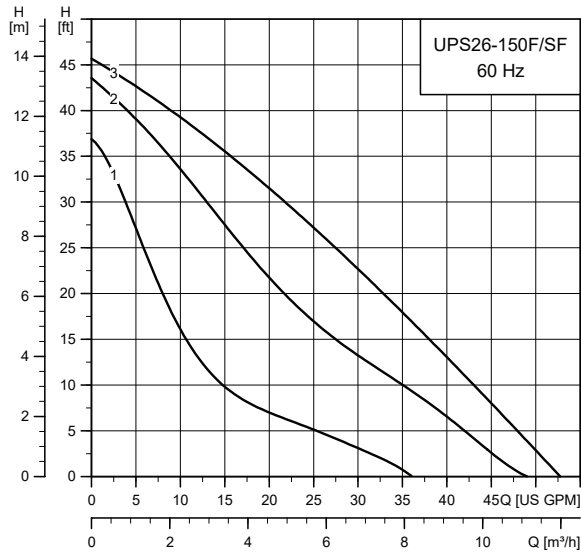

UPS 26-150 F/SF

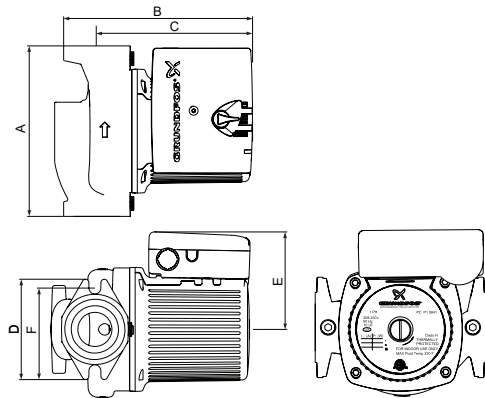

TM04 6014

Flow range: 0-53 gpm (0-12 m³h)
 Head range: 0-46 ft (0-14 m)
 Motors: 2-pole, single-phase
 Max. liquid temperature: 230 °F (110 °C)
 Min. liquid temperature: 36 °F (2 °C)
 Max. system pressure: 145 psi (10 bar)

Model	Speed	Volts	Amps	Watts	Hp	Capacitor
UPS 26-150 F/SF	3	115	3.5	370	½	40µF/180 V
	2		3.1	335	½	
	1		2.5	265	½	
	3	208	1.7	350	½	10µF/400 V
	2		1.5	310	½	
	1		1.2	250	½	
	3	230	1.7	370	½	10µF/400 V
	2		1.5	335	½	
	1		1.2	265	½	

Model Type	Product Number		Dimensions [inches (mm)]						Connection Type and Size	Shipping Weight [lbs (kg)]
	115 V	208 - 230 V	A	B	C	D	E	F		
UPS 26-150 F	95906630	95906631	6.50 (165)	7.13 (181)	5.88 (149)	3.88 (98)	3.75 (95)	3.13 (79)	GF 15/26 flange (2) 1/2" dia. bolt holes	17.4 (7.9)
UPS 26-150 SF	95906632	95906633	6.50 (165)	7.13 (181)	5.88 (149)	3.88 (98)	3.75 (95)	3.13 (79)	GF 15/26 flange (2) 1/2" dia. bolt holes	17.4 (7.9)

Approvals



Dimensions in inches unless otherwise noted.

• **FLOWCON VALVE**

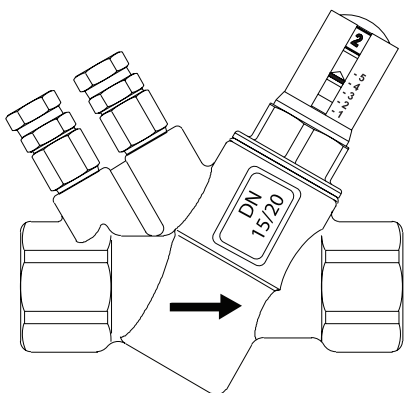

Specifications

Pressure/Temp. Rating: 2500 kPa / -30° C to +100° C

Material:

- Cartdrige: Polyoxymethylene
- Diaphragm: Hydrogenated acrylonitrile-butadiene- rubber or EPDM depending on type
- Body: Forged brass ASTM CuZn39Pb2
- O-Rings: EPDM
- End Connections: Female ISO
- Body tappings: ¼" ISO
- Flow Rate Range: 0.0081 I/s - 1.43 I/s (standard composite)
0.0278 I/s - 1.39 I/s (E-JUST)

		A/AB DN15/20/25 ABV DN15/20/25				AB DN25/32 ABV DN25/32/40				AB DN40/50	
Static Pressure	(kPa)	2500									
	(psi)	360									
Temperature Rating (media/ambient)	(°C)	-20 to +120 / 0 to +50									
	(°F)	-4 to +248 / +32 to +122									
Pressure Drop Data		NOTE: For pump head calculations, add the minimum pressure differential for the index circuit to the other components pressure losses (i.e. valves, coil, etc.)									
Valve Body	(Kv-value)	3.1				12.5				23.0	
	(Cv-value)	3.6				14.5				30.4	
Stainless Steel Insert		F3601xx	F3602xx	F3604xx	F3608xx	F3611xx	F3612xx	F3614xx	F3618xx	N/A	
Insert Size	(mm)	20	20	20	20	40	40	40	40		
	(inch)	3/4"	3/4"	3/4"	3/4"	1 1/2"	1 1/2"	1 1/2"	1 1/2"		
Pressure	(kPaD)	10-95	22-210	40-390	90-880	10-95	22-210	40-390	90-880		
Differential	(psid)	1-14	2-32	4-57	8-128	1-14	2-32	4-57	8-128		
Flow Rate	(I/sec)	0.0210-0.315	0.0347-0.505	0.0473-0.631	0.0694-1.01	0.189-0.925	0.284-1.39	0.379-1.85	0.568-2.78		
	(GPM)	0.333-5.00	0.550-8.00	0.750-10.0	1.10-16.0	3.00-14.7	4.50-22.0	6.00-29.3	9.00-44.0		
Standard Composite Insert		ABV1.Y.x grey/red/blue/black/green		ABV1.G.x grey/red/blue/black/green		ABV2.X.x red/white	ABV2.C.x red/white	ABV2.D.x red/white		N/A	
Insert Size	(mm)	20		20		40	40	40			
	(inch)	3/4"		3/4"		1 1/2"	1 1/2"	1 1/2"			
Pressure	(kPaD)	15-130		30-400		15-130	22-300	30-410			
Differential	(psid)	2.2-18.9		4.4-58		2.2-18.9	3.2-43.5	4.4-59.5			
Flow Rate	(I/sec)	0.0081-0.273		0.0117-0.408		0.17-0.85	0.23-1.21	0.27-1.43			
	(GPM)	0.128-4.33		0.185-6.46		2.69-13.5	3.65-19.2	4.28-22.7			
E-JUST Insert		E-JUST1.Y.x black/green	E-JUST1.Y.R red	E-JUST1.G.R red	E-JUST1.G.x black/green	E-JUST2.Y.G green			E-JUST3.G.B black		
Insert Size	(mm)	20	20	20	20	40			50		
	(inch)	3/4"	3/4"	3/4"	3/4"	1 1/2"			2"		
Pressure	(kPaD)	17-210	17-200	30-400	35-400	17-400			20-400		
Differential	(psid)	2.5-30	2.5-29	4.4-58	5.1-58	2.5-58			2.9-58		
Flow Rate	(I/sec)	0.0278-0.169	0.0767-0.229	0.113-0.352	0.0383-0.249	0.149-1.62			0.883-4.48		
	(GPM)	0.44-2.68	1.22-3.60	1.79-5.57	0.607-3.95	2.36-25.7			14.0-70.9		

	Model no. E-JUST2.Y.G			Flowcon Setting
	l/sec	l/hr	GPM	
3 TR.	0.149	535	2.36	1.0
	0.220	793	3.49	1.1
	0.289	1040	4.58	1.2
	0.355	1280	5.63	1.3
	0.418	1510	6.63	1.4
	0.479	1730	7.60	1.5
	0.538	1940	8.52	1.6
	0.594	2140	9.41	1.7
	0.647	2330	10.30	1.8
	0.699	2520	11.10	1.9
5 TR.	0.748	2690	11.90	2.0
	0.795	2860	12.60	2.1
	0.841	3030	13.30	2.2
	0.884	3180	14.00	2.3
	0.925	3330	14.70	2.4
	0.965	3470	15.30	2.5
	1.000	3610	15.90	2.6
	1.040	3740	16.50	2.7
	1.070	3870	17.00	2.8
	1.110	3990	17.60	2.9
7.5 TR.	1.140	4100	18.10	3.0
	1.170	4220	18.60	3.1
	1.200	4320	19.00	3.2
	1.230	4420	19.50	3.3
	1.260	4520	19.90	3.4
	1.280	4620	20.30	3.5
	1.310	4710	20.70	3.6
	1.330	4800	21.10	3.7
	1.360	4890	21.50	3.8
	1.380	4970	21.90	3.9
10 TR.	1.400	5050	22.30	4.0
	1.430	5130	22.60	4.1
	1.450	5210	23.00	4.2
	1.470	5290	23.30	4.3
	1.490	5370	23.60	4.4
	1.510	5440	24.00	4.5
	1.530	5520	24.30	4.6

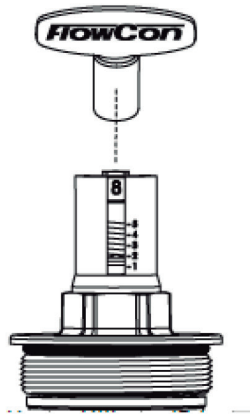
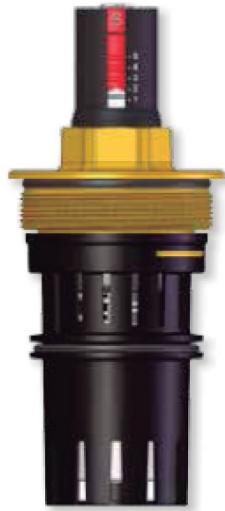

Pressure range ΔP : 20-400 kPaD 2.9-58 psid

	Model no. E-JUST3.G.B			Flowcon Setting
	l/sec	l/hr	GPM	
12.5 TR.	0.883	3180	14.0	1.0
	1.140	4100	18.0	1.1
	1.700	4940	21.7	1.2
	1.590	5710	25.1	1.3
	1.780	6420	28.3	1.4
	1.960	7070	31.1	1.5
	2.130	7660	33.7	1.6
	2.280	8200	36.1	1.7
	2.410	8700	38.3	1.8
	2.540	9150	40.3	1.9
25 TR.	2.660	9570	42.1	2.0
	2.770	9960	43.8	2.1
	2.860	10300	45.4	2.2
	2.950	10600	46.8	2.3
	3.040	10900	48.2	2.4
	3.120	11200	49.4	2.5
	3.190	11500	50.6	2.6
	3.260	11700	51.7	2.7
	3.320	12000	52.7	2.8
	3.390	12200	53.7	2.9
50 TR.	3.450	12400	54.6	3.0
	3.510	12600	55.6	3.1
	3.560	12800	56.5	3.2
	3.620	13000	57.3	3.3
	3.670	13200	58.2	3.4
	3.730	13400	59.1	3.5
	3.780	13600	59.9	3.6
	3.830	13800	60.8	3.7
	3.890	14000	61.6	3.8
	3.940	14200	62.4	3.9
75 TR.	3.990	14400	63.3	4.0
	4.050	14600	64.1	4.1
	4.100	14800	65.0	4.2
	4.150	14900	65.8	4.3
	4.200	15100	66.6	4.4
	4.250	15300	67.4	4.5
	4.300	15500	68.2	4.6
	4.350	15700	68.9	4.7

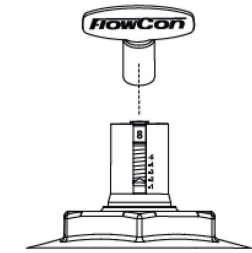

GENERAL DESCRIPTION

DIMENSIONS AND WEIGHTS (NOMINAL) (measured in mm unless noted)

Model no.	Valve size	Cartridge size	L	H1	H2	H3	Weight (lbs.)	Cv ¹ (GPM)
AB	½"	¾"	3.23	2.60	1.22	3.07	1.1	3
	¾"		3.70				1.2	
	1"		4.02				1.4	
AB	1"	1 ½"	5.04	3.27	1.85	3.93	4.5	14.5
	1 ¼"						4.0	
	1 ½"	2	6.65	N/A	2.15	4.61	8.9	26.7
	2"						7.8	

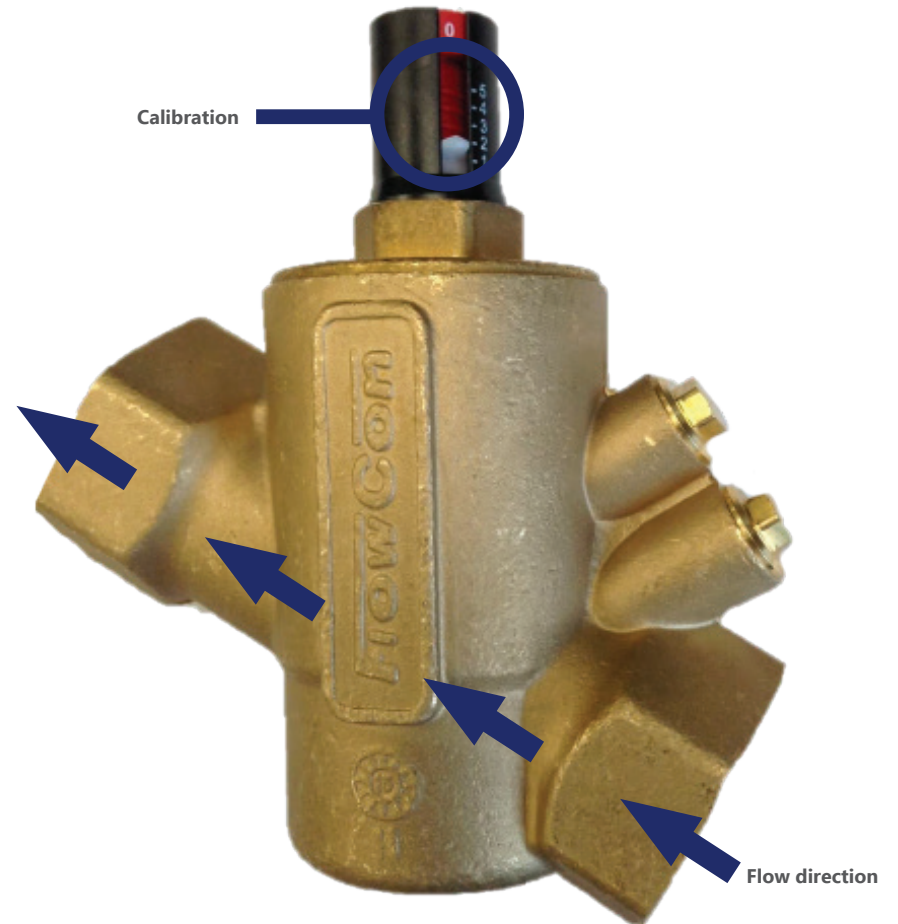
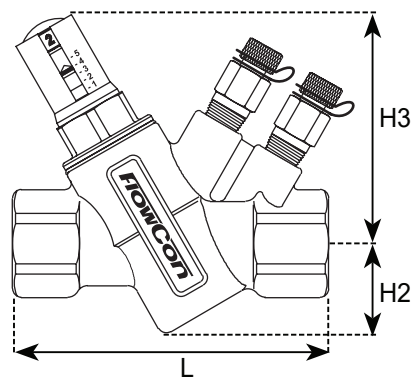
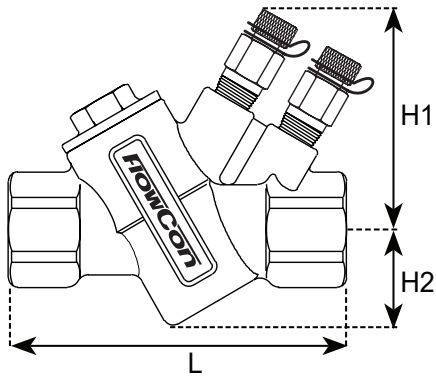

VISTA SUPERIOR

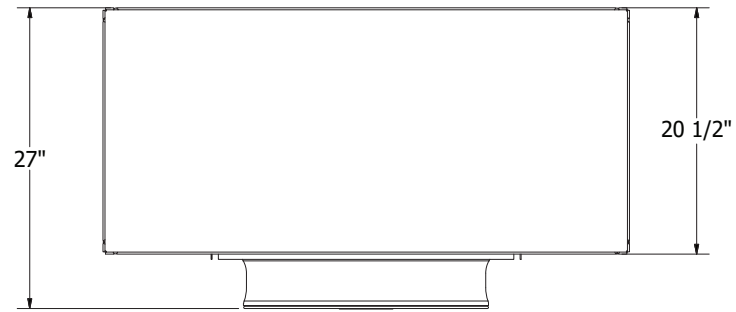

VISTA LATERAL

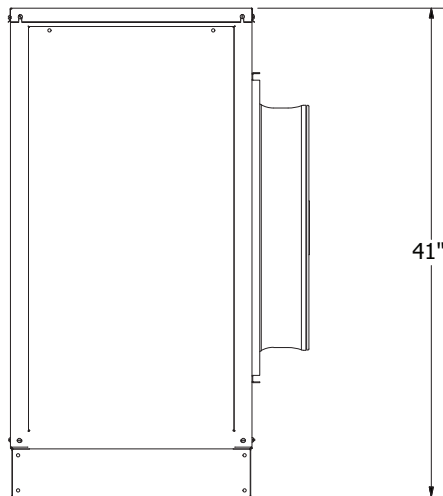

VISTA FRONTAL

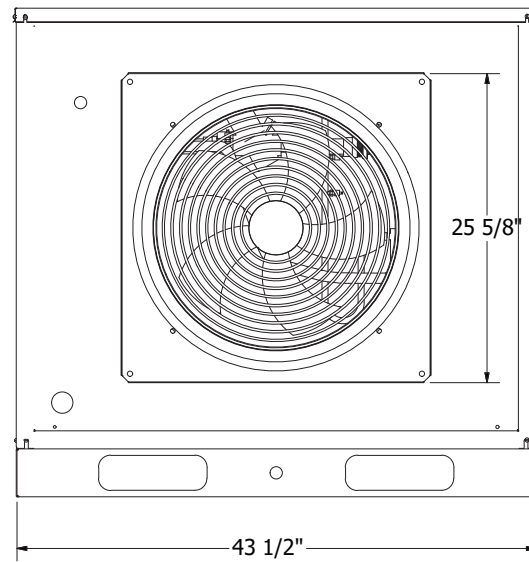

VISTA ISOMÉTRICA

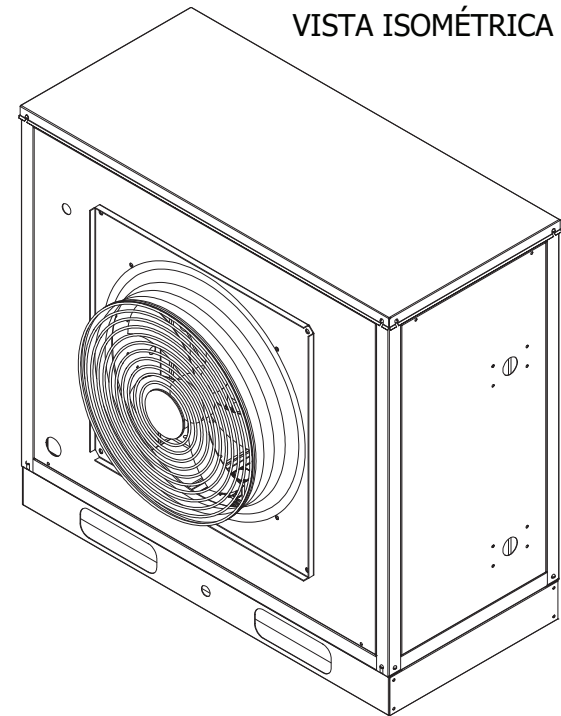

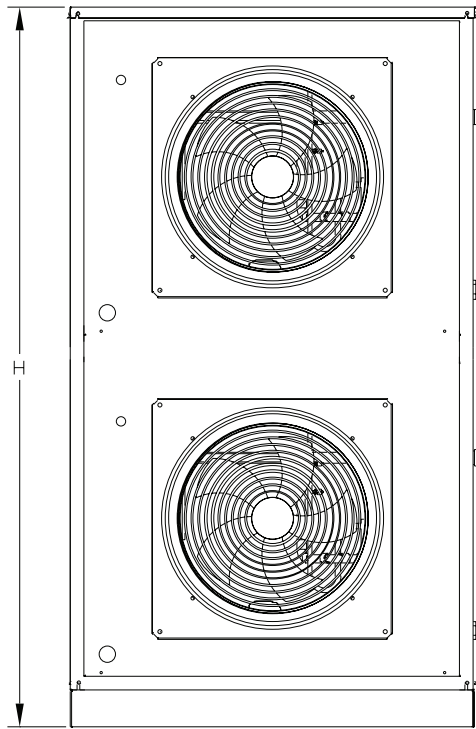

VISTA FRONTAL

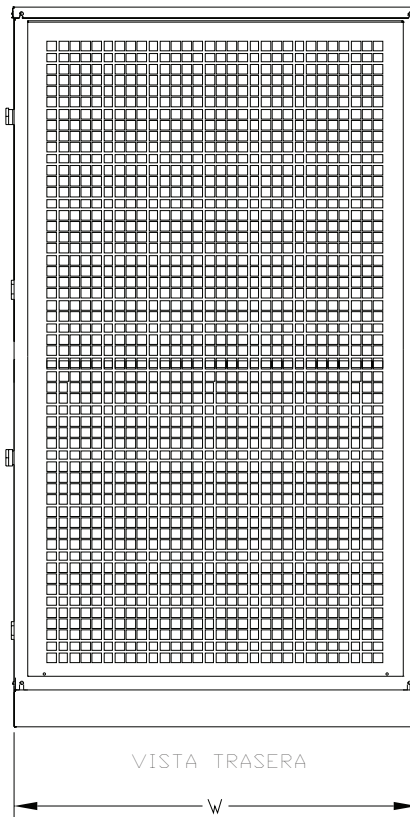

VISTA TRASERA

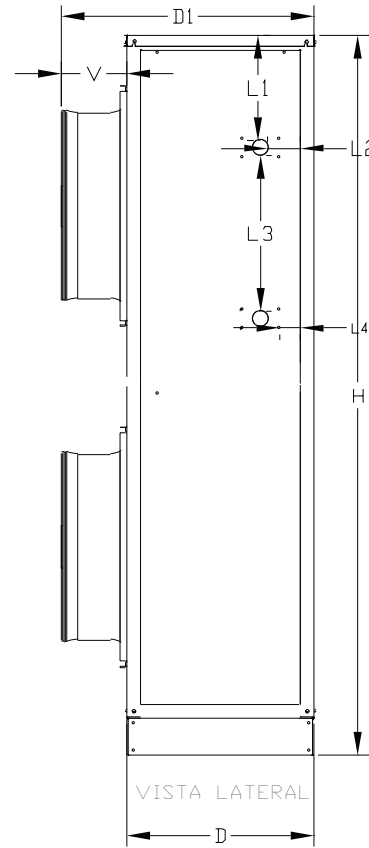

VISTA LATERAL

H	76"
W	43¼"
D	20¼"
D1	27¼"
L1	4.4"
L2	6.5"
L3	1.35"
L4	.85"
V	.7"

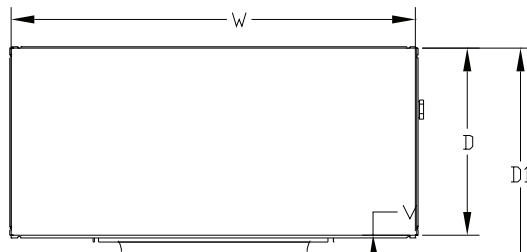

VISTA SUPERIOR

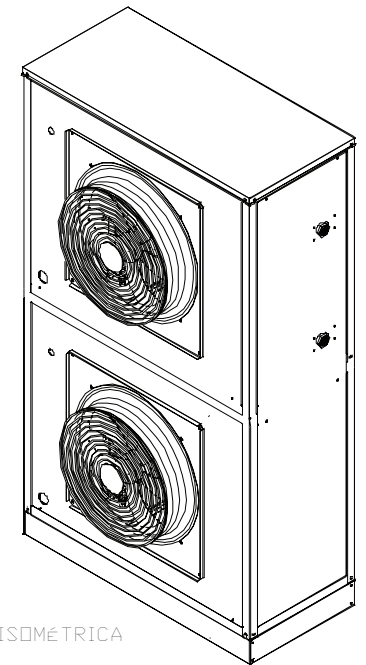

VISTA ISOMÉTRICA

SIMBOLOGY	
#	CONCEPT
1	HIGH PRESSURE SENSOR
2	ULTRASONIC WATER FLOW SENSOR
3	LOW PRESSURE SENSOR
4	OUTLET SENSOR
5	INLET SENSOR
6	FREEZING SENSOR
7	SENSOR CONDENSER
8	OUTLET GENERAL SENSOR (optional)
9	INLET GENERAL SENSOR (optional)
10	SECOND STAGE
# TYPE OF COLOR WIRE	
—	STRIPED LINE
—	SOLID LINE
# WIRE SPECIFICATION SIZE	
①	WIRE BORE 3 X 8 AWG SHIELDED
①	WIRE BORE 8 AWG
②	WIRE BORE 14 AWG
③	WIRE BORE 16 AWG
④	WIRE BORE 18 AWG
⑤	WIRE BORE 3 X 18 AWG SHIELDED
⑥	WIRE BORE 2 X 18 AWG SHIELDED
⑦	WIRE BORE 2 X 22 AWG SHIELDED
⑧	WIRE BORE 4 AWG
⑨	WIRE BORE 2 AWG
⑩	WIRE BORE 6 AWG
# SIGNAL TYPE	
—	HIGH VOLTAGE
- - -	VOLTAGE "CLASS 2"
—+—+—+—	RESISTANCE SIGNAL
⋯⋯⋯	DIGITAL SIGNAL

CLASS 2

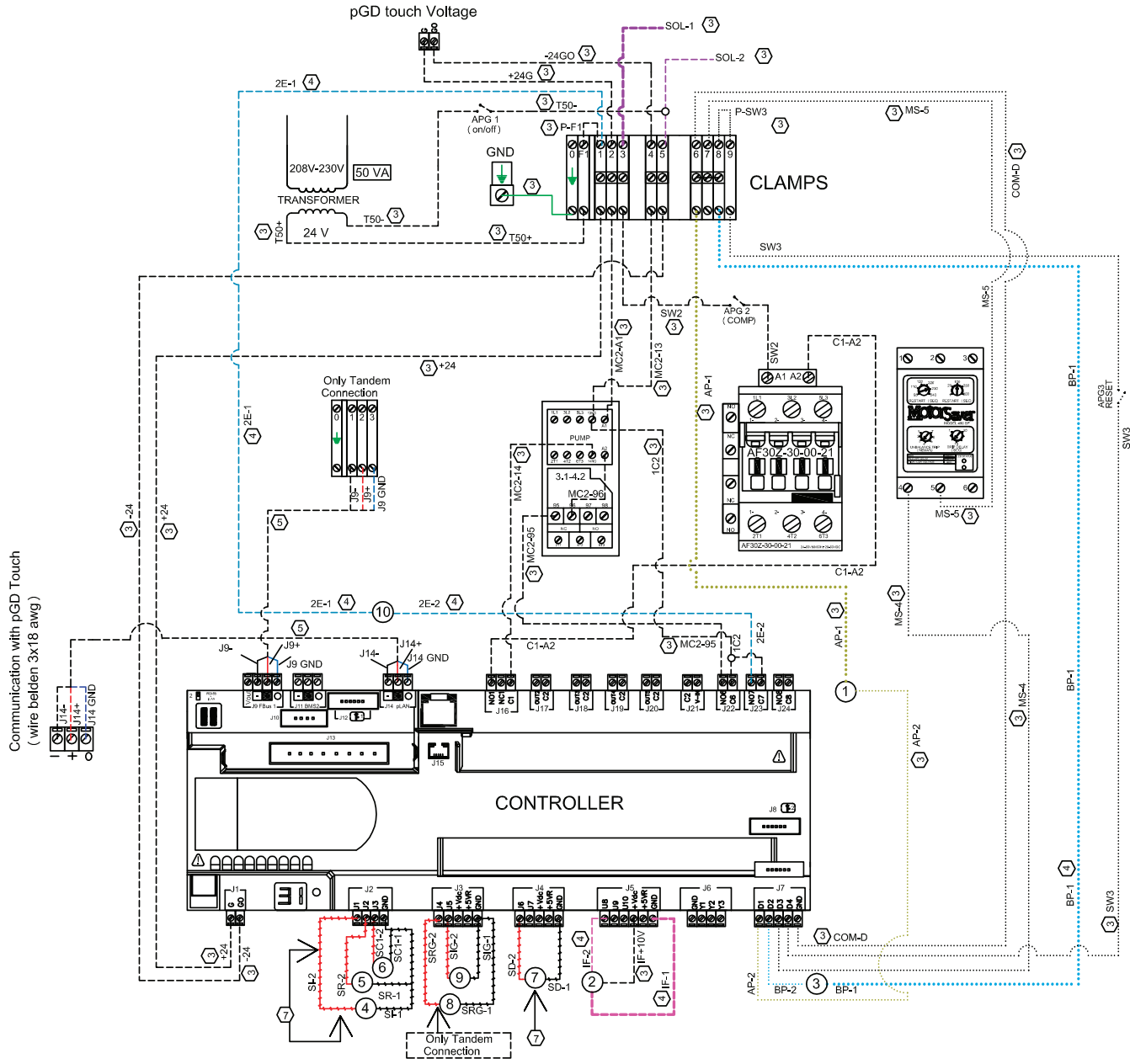

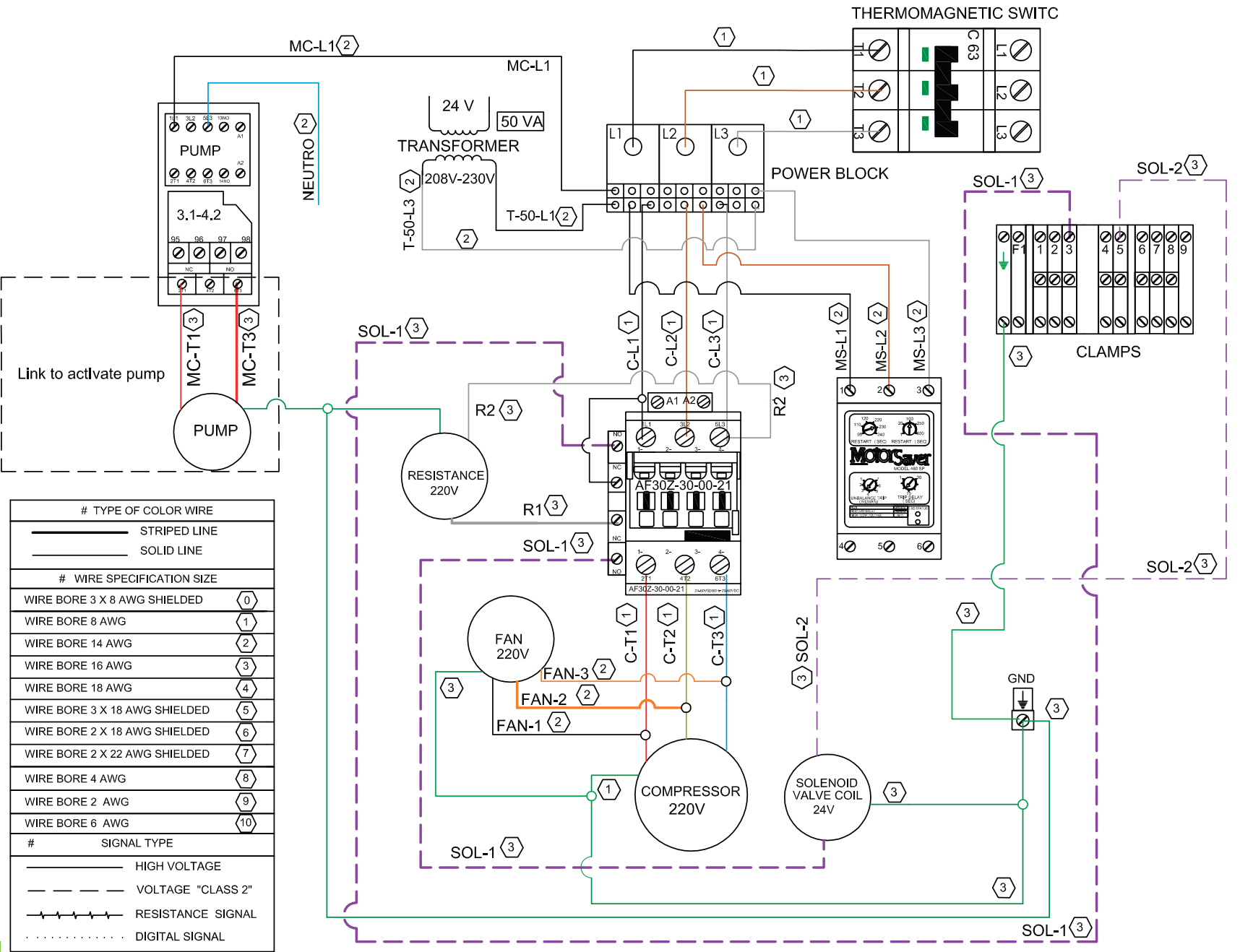

CLIV-AGG-036-A3S-S DIAGRAMA DE CONTROL

SIMBOLOGY	
#	CONCEPT
1	HIGH PRESSURE SENSOR
2	ULTRASONIC WATER FLOW SENSOR
3	LOW PRESSURE SENSOR
4	OUTLET SENSOR
5	INLET SENSOR
6	FREEZING SENSOR
7	SENSOR CONDENSER
8	OUTLET GENERAL SENSOR (optional)
9	INLET GENERAL SENSOR (optional)
10	SECOND STAGE
# TYPE OF COLOR WIRE	
—	STRIPED LINE
—	SOLID LINE
# WIRE SPECIFICATION SIZE	
①	WIRE BORE 3 X 8 AWG SHIELDED
①	WIRE BORE 8 AWG
②	WIRE BORE 14 AWG
③	WIRE BORE 16 AWG
④	WIRE BORE 18 AWG
⑤	WIRE BORE 3 X 18 AWG SHIELDED
⑥	WIRE BORE 2 X 18 AWG SHIELDED
⑦	WIRE BORE 2 X 22 AWG SHIELDED
⑧	WIRE BORE 4 AWG
⑨	WIRE BORE 2 AWG
⑩	WIRE BORE 6 AWG
# SIGNAL TYPE	
—	HIGH VOLTAGE
- - -	VOLTAGE "CLASS 2"
—+—+—+—	RESISTANCE SIGNAL
.....	DIGITAL SIGNAL

CLASS 2

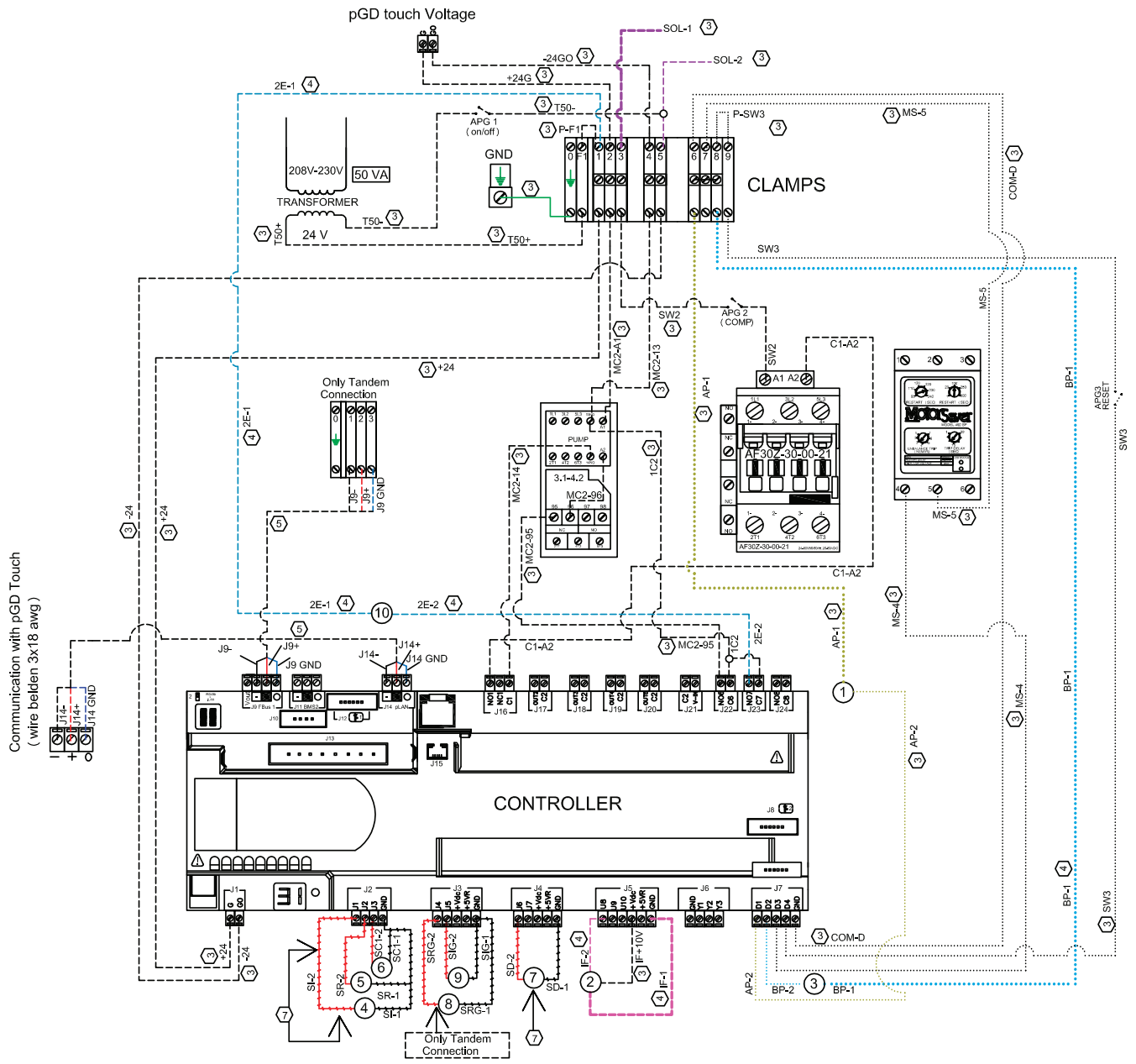

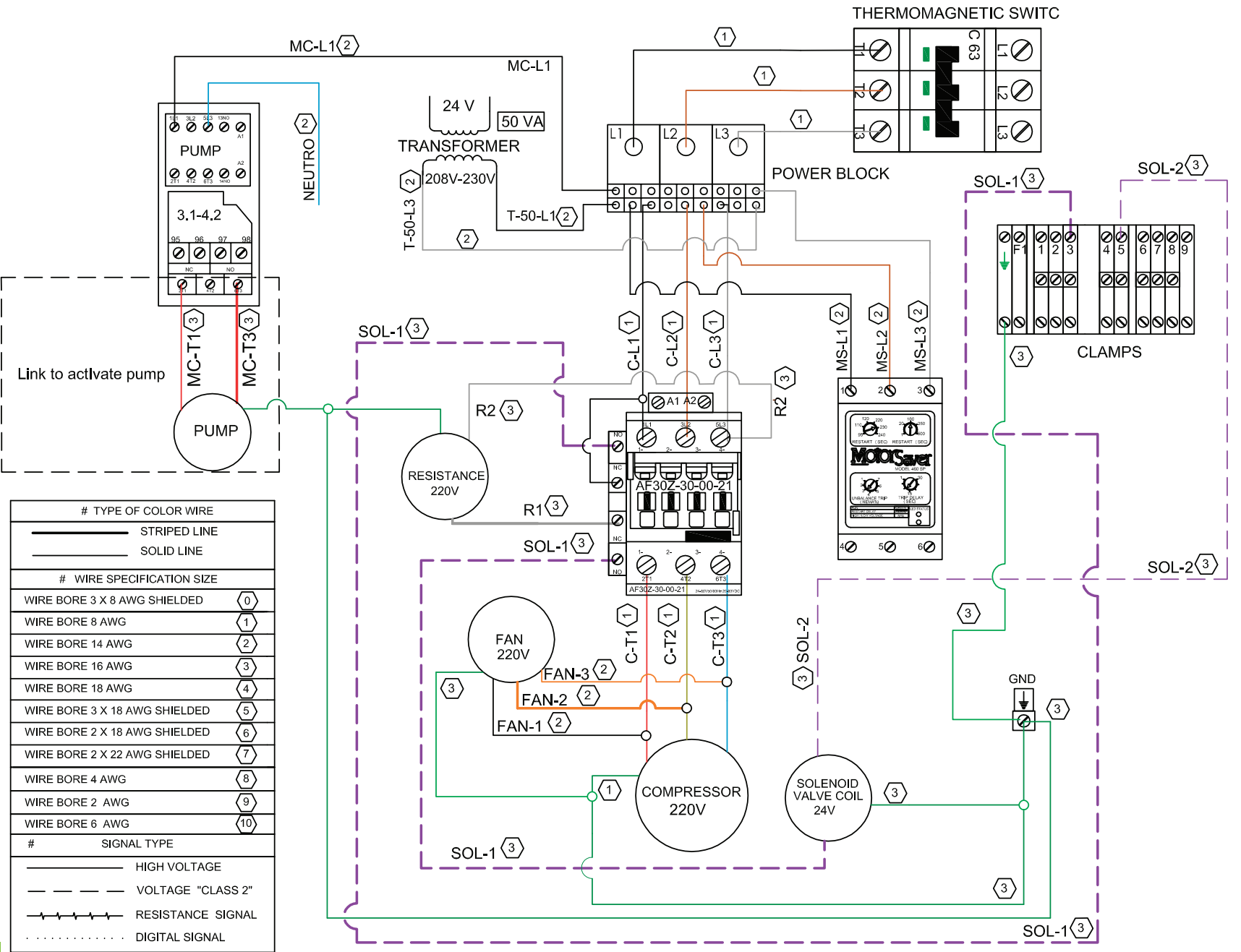

SIMBOLOGY	
#	CONCEPT
1	HIGH PRESSURE SENSOR
2	ULTRASONIC WATER FLOW SENSOR
3	LOW PRESSURE SENSOR
4	OUTLET SENSOR
5	INLET SENSOR
6	FREEZING SENSOR
7	SENSOR CONDENSER
8	OUTLET GENERAL SENSOR (optional)
9	INLET GENERAL SENSOR (optional)
10	SECOND STAGE
# TYPE OF COLOR WIRE	
—	STRIPED LINE
—	SOLID LINE
# WIRE SPECIFICATION SIZE	
①	WIRE BORE 3 X 8 AWG SHIELDED
①	WIRE BORE 8 AWG
②	WIRE BORE 14 AWG
③	WIRE BORE 16 AWG
④	WIRE BORE 18 AWG
⑤	WIRE BORE 3 X 18 AWG SHIELDED
⑥	WIRE BORE 2 X 18 AWG SHIELDED
⑦	WIRE BORE 2 X 22 AWG SHIELDED
⑧	WIRE BORE 4 AWG
⑨	WIRE BORE 2 AWG
⑩	WIRE BORE 6 AWG
# SIGNAL TYPE	
—	HIGH VOLTAGE
- - - - -	VOLTAGE "CLASS 2"
—+—+—+—+—	RESISTANCE SIGNAL
.....	DIGITAL SIGNAL

CLASS 2

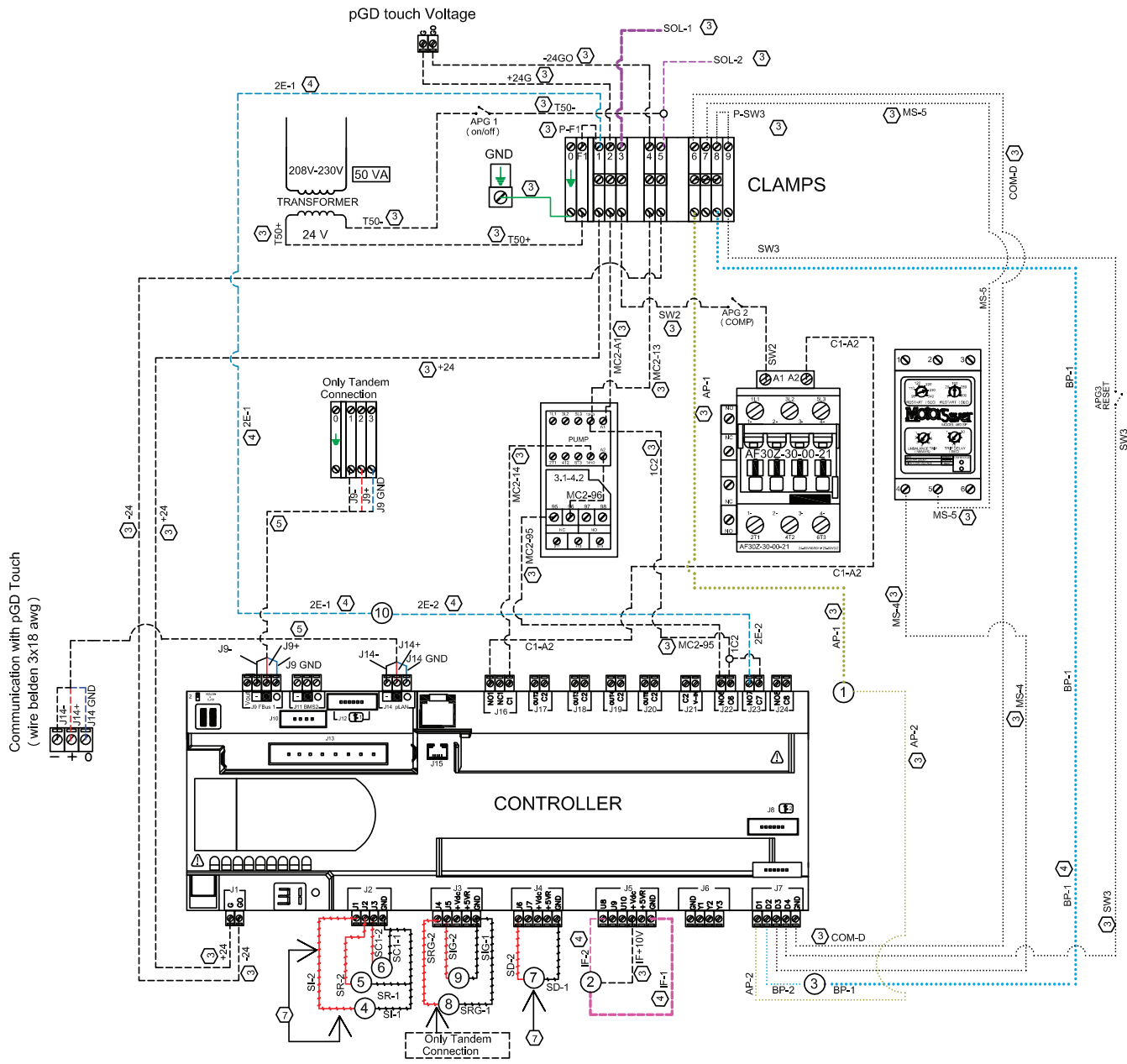

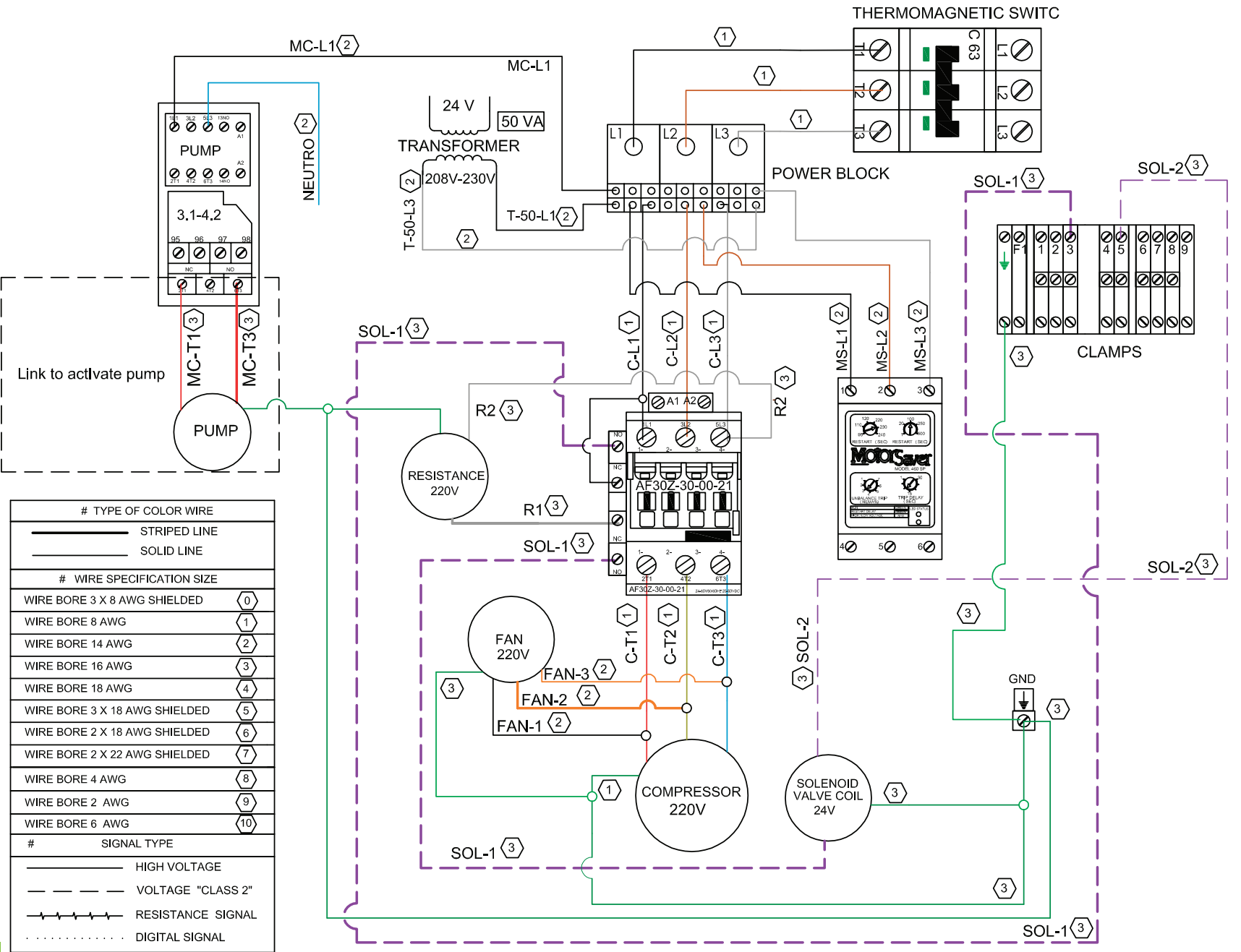

# TYPE OF COLOR WIRE	
— (Striped)	STRIPED LINE
— (Solid)	SOLID LINE
# WIRE SPECIFICATION SIZE	
WIRE BORE 3 X 8 AWG SHIELDED	0
WIRE BORE 8 AWG	1
WIRE BORE 14 AWG	2
WIRE BORE 16 AWG	3
WIRE BORE 18 AWG	4
WIRE BORE 3 X 18 AWG SHIELDED	5
WIRE BORE 2 X 18 AWG SHIELDED	6
WIRE BORE 2 X 22 AWG SHIELDED	7
WIRE BORE 4 AWG	8
WIRE BORE 2 AWG	9
WIRE BORE 6 AWG	10
# SIGNAL TYPE	
— (Solid)	HIGH VOLTAGE
- - - (Dashed)	VOLTAGE "CLASS 2"
— (Wavy)	RESISTANCE SIGNAL
· · · · · (Dotted)	DIGITAL SIGNAL

CLV-AGG-060-A3S-S DIAGRAMA DE CONTROL

SIMBOLOGY	
#	CONCEPT
1	HIGH PRESSURE SENSOR
2	SECOND STAGE
3	ULTRASONIC WATER FLOW SENSOR
4	LOW PRESSURE SENSOR
5	OUTLET SENSOR
6	INLET SENSOR
7	FREEZING SENSOR
8	SENSOR CONDENSER
#	TYPE OF COLOR WIRE
—	STRIPED LINE
—	SOLID LINE
#	WIRE SPECIFICATION SIZE
0	WIRE BORE 3 X 8 AWG SHIELDED
1	WIRE BORE 8 AWG
2	WIRE BORE 14 AWG
3	WIRE BORE 16 AWG
4	WIRE BORE 18 AWG
5	WIRE BORE 3 X 18 AWG SHIELDED
6	WIRE BORE 2 X 18 AWG SHIELDED
7	WIRE BORE 2 X 22 AWG SHIELDED
8	WIRE BORE 4 AWG
9	WIRE BORE 2 AWG
10	WIRE BORE 6 AWG
#	SIGNAL TYPE
—	HIGH VOLTAGE
- - -	VOLTAGE "CLASS 2"
—+—+—+—+—	RESISTANCE SIGNAL
.....	DIGITAL SIGNAL

CLASS 2

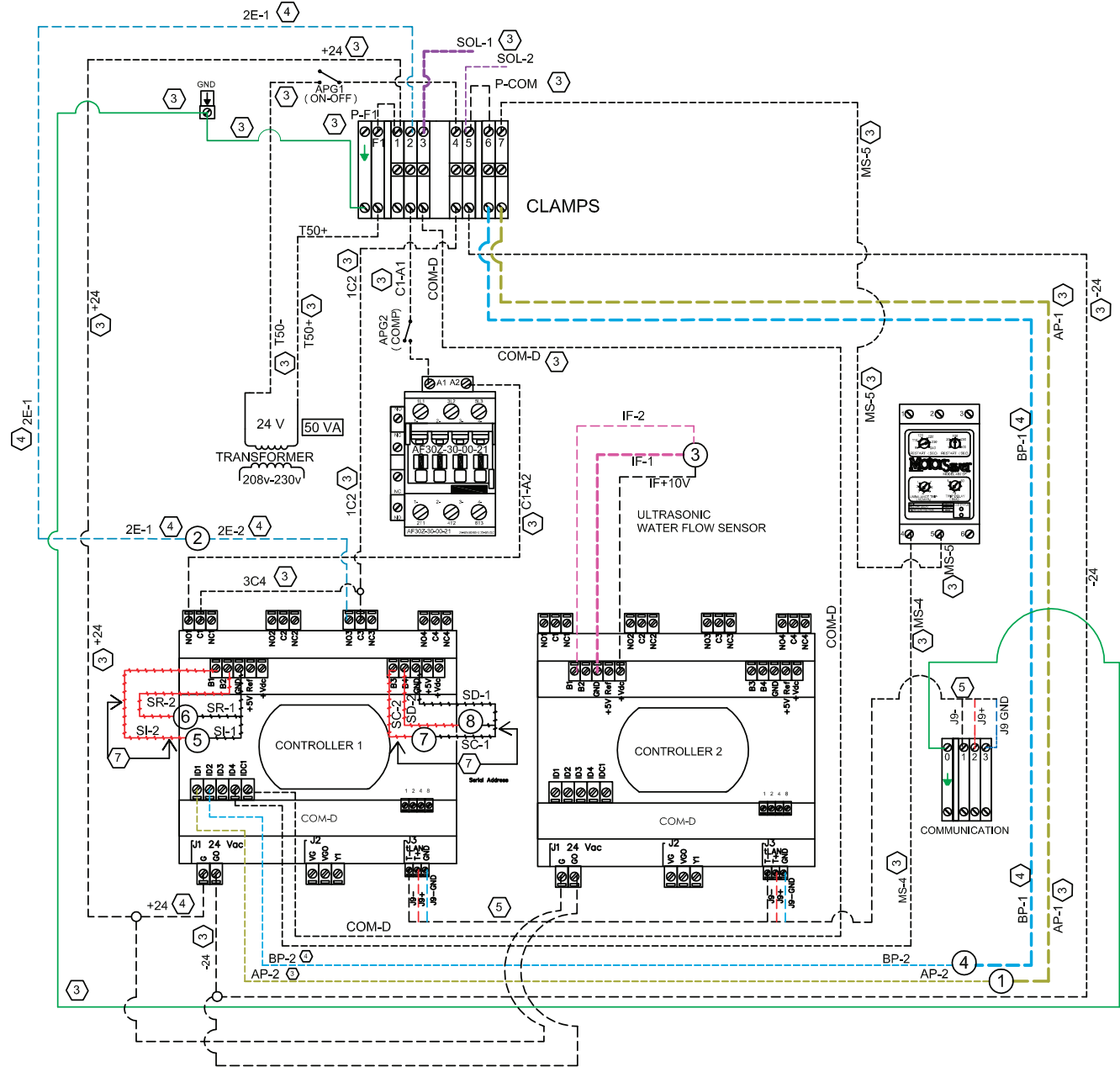

# TYPE OF COLOR WIRE	
	STRIPED LINE
	SOLID LINE
# WIRE SPECIFICATION SIZE	
WIRE BORE 3 X 8 AWG SHIELDED	0
WIRE BORE 8 AWG	1
WIRE BORE 14 AWG	2
WIRE BORE 16 AWG	3
WIRE BORE 18 AWG	4
WIRE BORE 3 X 18 AWG SHIELDED	5
WIRE BORE 2 X 18 AWG SHIELDED	6
WIRE BORE 2 X 22 AWG SHIELDED	7
WIRE BORE 4 AWG	8
WIRE BORE 2 AWG	9
WIRE BORE 6 AWG	10
#	SIGNAL TYPE
	HIGH VOLTAGE
	VOLTAGE "CLASS 2"
	RESISTANCE SIGNAL
	DIGITAL SIGNAL

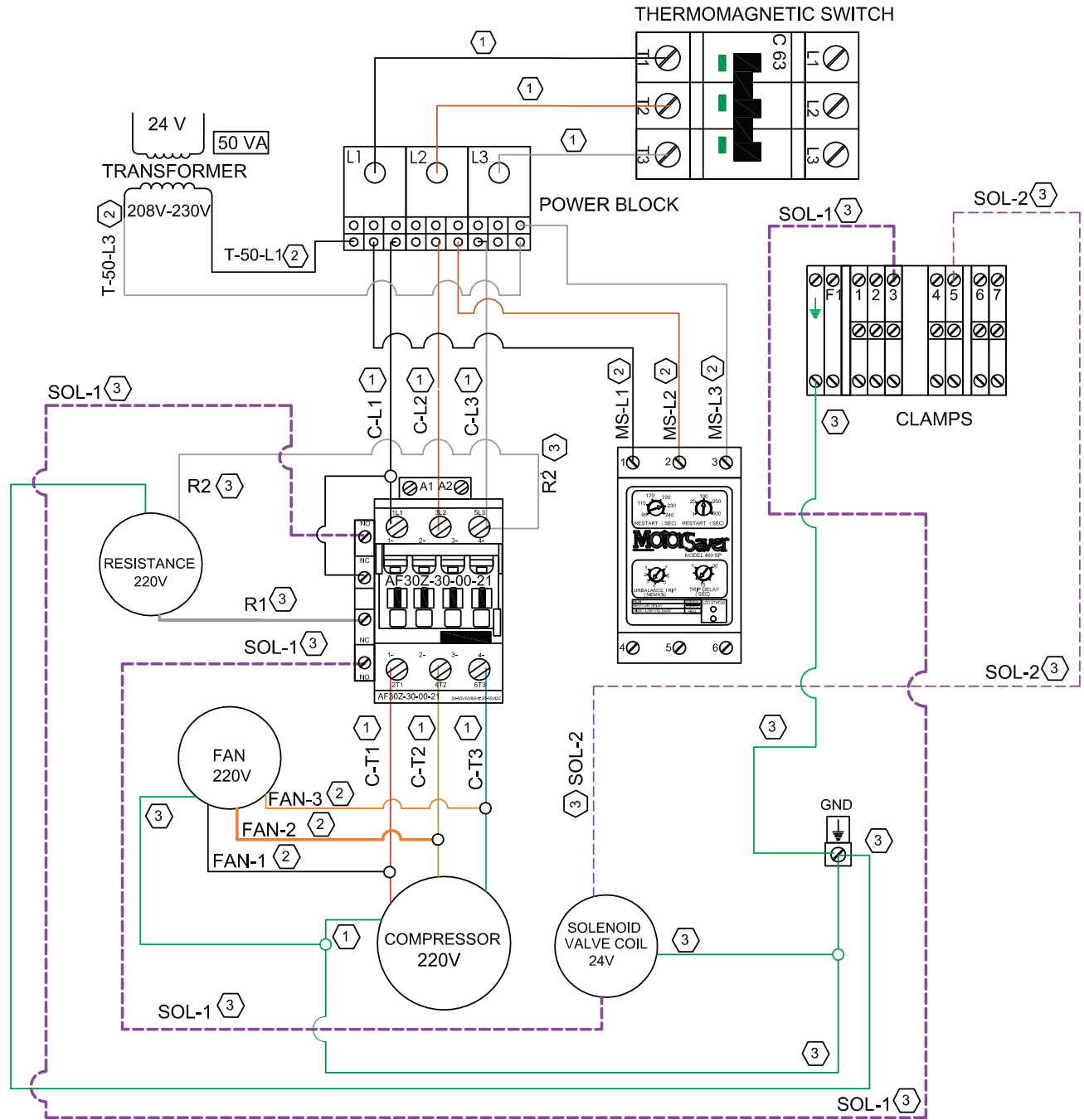

CLIV-AGH-036-A3S-M DIAGRAMA DE CONTROL

ELECTRICAL INFORMATION

SIMBOLOGY	
#	CONCEPT
1	HIGH PRESSURE SENSOR
2	ULTRASONIC WATER FLOW SENSOR
3	LOW PRESSURE SENSOR
4	OUTLET SENSOR
5	INLET SENSOR
6	FREEZING SENSOR
7	SENSOR CONDENSER
8	OUTLET GENERAL SENSOR (optional)
9	INLET GENERAL SENSOR (optional)
10	SECOND STAGE
11	THREE WAY REGULATION COIL
# TYPE OF COLOR WIRE	
	STRIPED LINE
	SOLID LINE
# WIRE SPECIFICATION SIZE	
WIRE BORE 3 X 8 AWG SHIELDED	(6)
WIRE BORE 8 AWG	(1)
WIRE BORE 14 AWG	(2)
WIRE BORE 16 AWG	(3)
WIRE BORE 18 AWG	(4)
WIRE BORE 3 X 18 AWG SHIELDED	(5)
WIRE BORE 2 X 18 AWG SHIELDED	(6)
WIRE BORE 2 X 22 AWG SHIELDED	(7)
WIRE BORE 4 AWG	(8)
WIRE BORE 2 AWG	(9)
WIRE BORE 6 AWG	(10)
# SIGNAL TYPE	
	HIGH VOLTAGE
	VOLTAGE "CLASS 2"
	RESISTANCE SIGNAL
	DIGITAL SIGNAL

CLASS 2

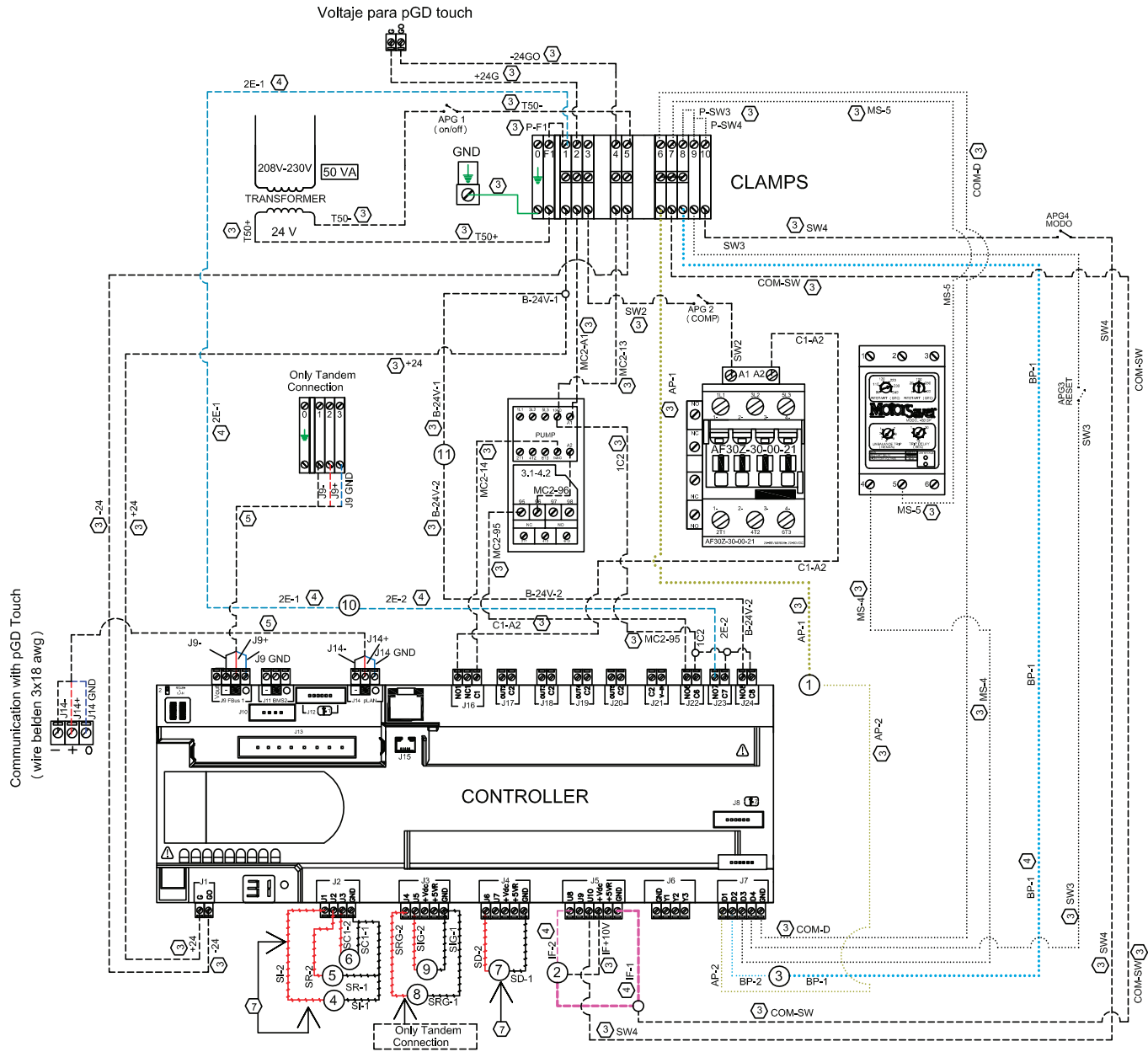

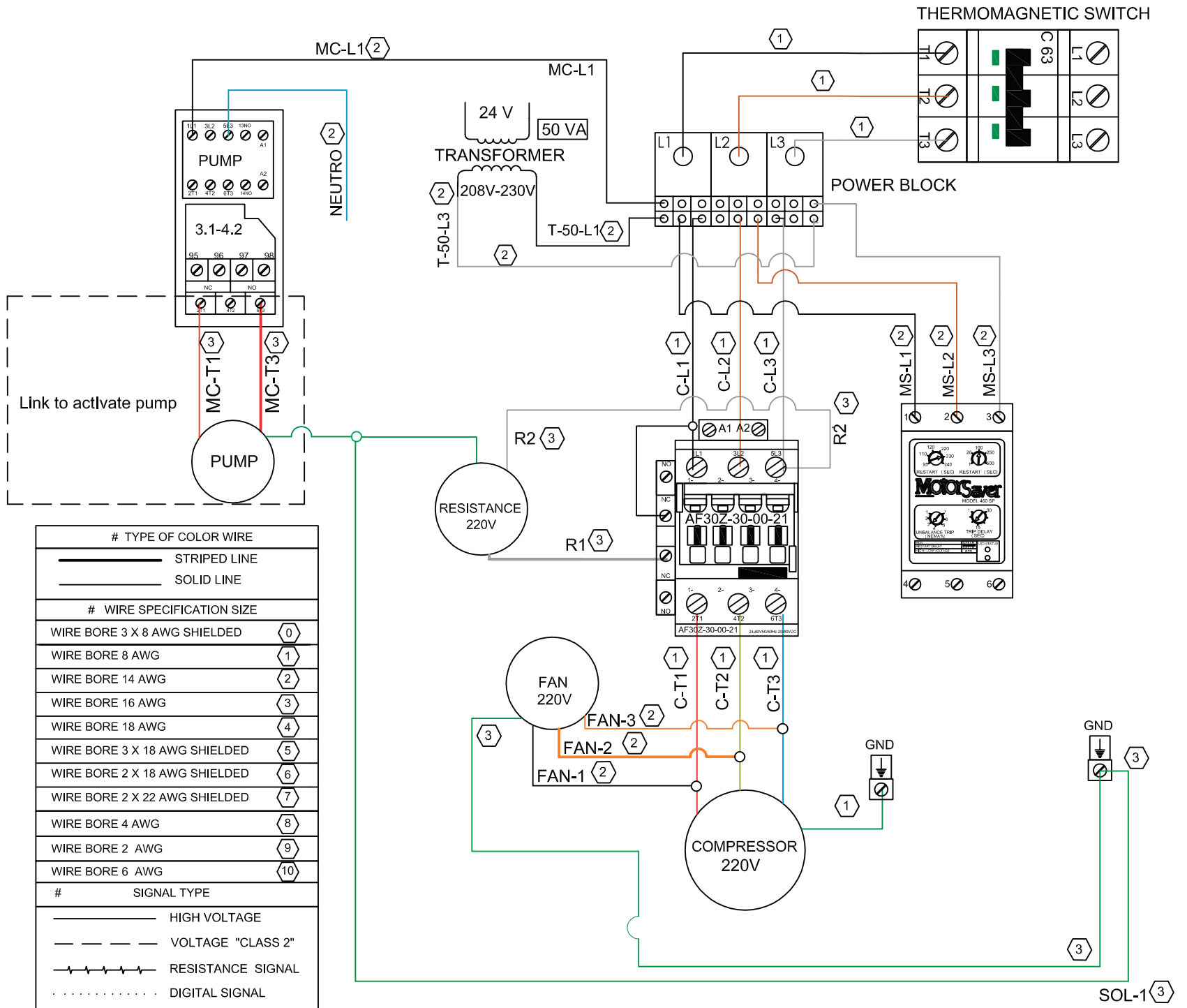





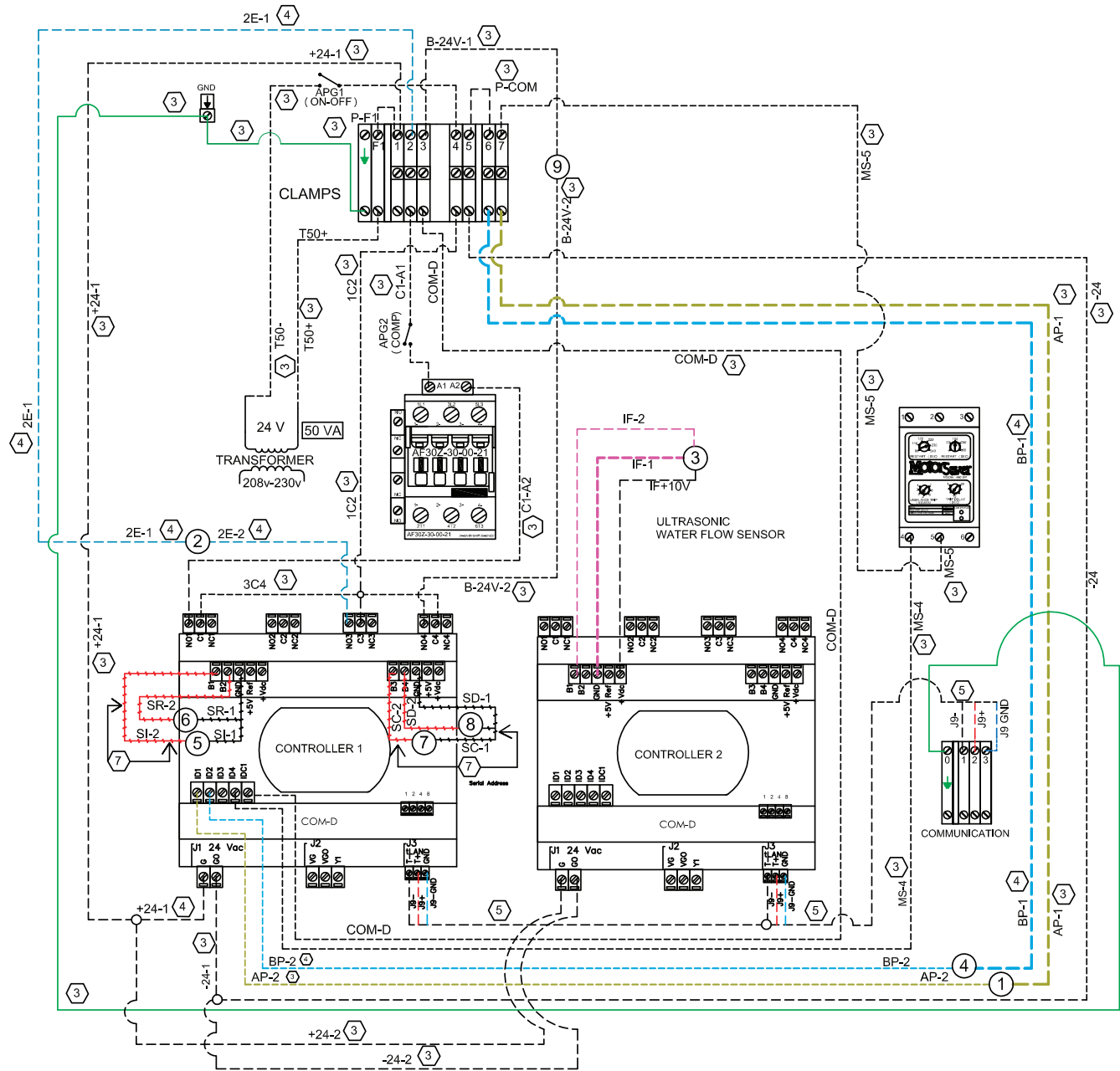

# TYPE OF COLOR WIRE	
— (with diagonal stripes)	STRIPED LINE
— (solid)	SOLID LINE
# WIRE SPECIFICATION SIZE	
WIRE BORE 3 X 8 AWG SHIELDED	0
WIRE BORE 8 AWG	1
WIRE BORE 14 AWG	2
WIRE BORE 16 AWG	3
WIRE BORE 18 AWG	4
WIRE BORE 3 X 18 AWG SHIELDED	5
WIRE BORE 2 X 18 AWG SHIELDED	6
WIRE BORE 2 X 22 AWG SHIELDED	7
WIRE BORE 4 AWG	8
WIRE BORE 2 AWG	9
WIRE BORE 6 AWG	10
# SIGNAL TYPE	
— (solid)	HIGH VOLTAGE
— (dashed)	VOLTAGE "CLASS 2"
— (with zigzag)	RESISTANCE SIGNAL
— (dotted)	DIGITAL SIGNAL

SIMBOLOGY	
#	CONCEPT
1	HIGH PRESSURE SENSOR
2	SECOND STAGE
3	ULTRASONIC WATER FLOW SENSOR
4	LOW PRESSURE SENSOR
5	OUTLET SENSOR
6	INLET SENSOR
7	FREEZING SENSOR
8	SENSOR CONDENSER
9	THREE WAY REGULATION COIL
#	TYPE OF COLOR WIRE
—	STRIPED LINE
—	SOLID LINE
#	WIRE SPECIFICATION SIZE
WIRE BORE 3 X 8 AWG SHIELDED	0
WIRE BORE 8 AWG	1
WIRE BORE 14 AWG	2
WIRE BORE 16 AWG	3
WIRE BORE 18 AWG	4
WIRE BORE 3 X 18 AWG SHIELDED	5
WIRE BORE 2 X 18 AWG SHIELDED	6
WIRE BORE 2 X 22 AWG SHIELDED	7
WIRE BORE 4 AWG	8
WIRE BORE 2 AWG	9
WIRE BORE 6 AWG	10
#	SIGNAL TYPE
—	HIGH VOLTAGE
---	VOLTAGE "CLASS 2"
—+—+—+—	RESISTANCE SIGNAL
.....	DIGITAL SIGNAL

CLASS 2



# TYPE OF COLOR WIRE	
	STRIPED LINE
	SOLID LINE
# WIRE SPECIFICATION SIZE	
WIRE BORE 3 X 8 AWG SHIELDED	0
WIRE BORE 8 AWG	1
WIRE BORE 14 AWG	2
WIRE BORE 16 AWG	3
WIRE BORE 18 AWG	4
WIRE BORE 3 X 18 AWG SHIELDED	5
WIRE BORE 2 X 18 AWG SHIELDED	6
WIRE BORE 2 X 22 AWG SHIELDED	7
WIRE BORE 4 AWG	8
WIRE BORE 2 AWG	9
WIRE BORE 6 AWG	10
# SIGNAL TYPE	
	HIGH VOLTAGE
	VOLTAGE "CLASS 2"
	RESISTANCE SIGNAL
	DIGITAL SIGNAL

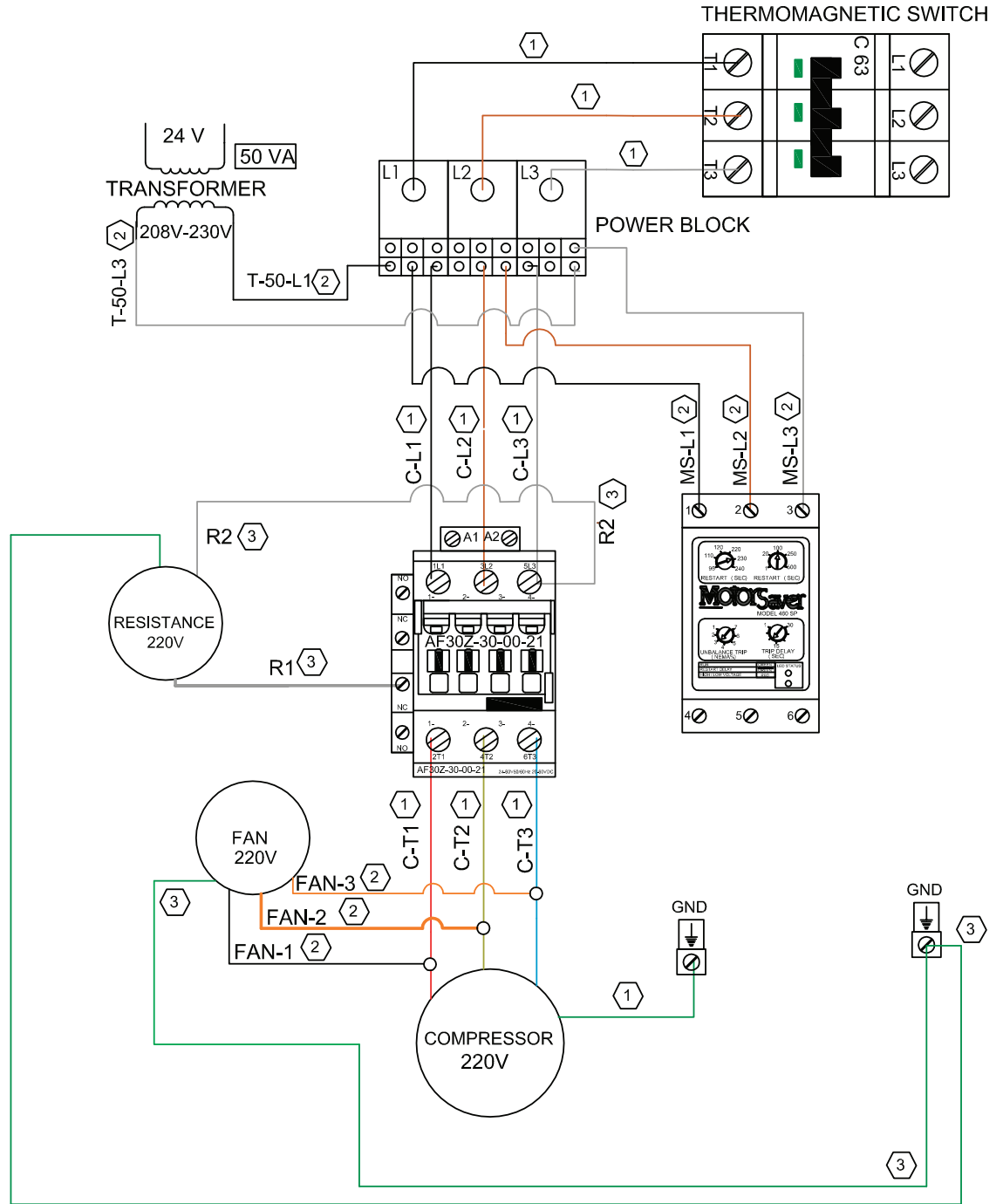

CLIV-AGH-060-A3S-M DIAGRAMA DE CONTROL

ELECTRICAL INFORMATION

SIMBOLOGY	
#	CONCEPT
1	HIGH PRESSURE SENSOR
2	ULTRASONIC WATER FLOW SENSOR
3	LOW PRESSURE SENSOR
4	OUTLET SENSOR
5	INLET SENSOR
6	FREEZING SENSOR
7	SENSOR CONDENSER
8	OUTLET GENERAL SENSOR (optional)
9	INLET GENERAL SENSOR (optional)
10	SECOND STAGE
11	THREE WAY REGULATION COIL
# TYPE OF COLOR WIRE	
—	STRIPED LINE
—	SOLID LINE
# WIRE SPECIFICATION SIZE	
WIRE BORE 3 X 8 AWG SHIELDED	①
WIRE BORE 8 AWG	②
WIRE BORE 14 AWG	③
WIRE BORE 16 AWG	④
WIRE BORE 18 AWG	⑤
WIRE BORE 3 X 18 AWG SHIELDED	⑥
WIRE BORE 2 X 18 AWG SHIELDED	⑦
WIRE BORE 2 X 22 AWG SHIELDED	⑧
WIRE BORE 4 AWG	⑨
WIRE BORE 2 AWG	⑩
WIRE BORE 6 AWG	⑪
# SIGNAL TYPE	
—	HIGH VOLTAGE
---	VOLTAGE "CLASS 2"
~	RESISTANCE SIGNAL
...	DIGITAL SIGNAL

CLASS 2

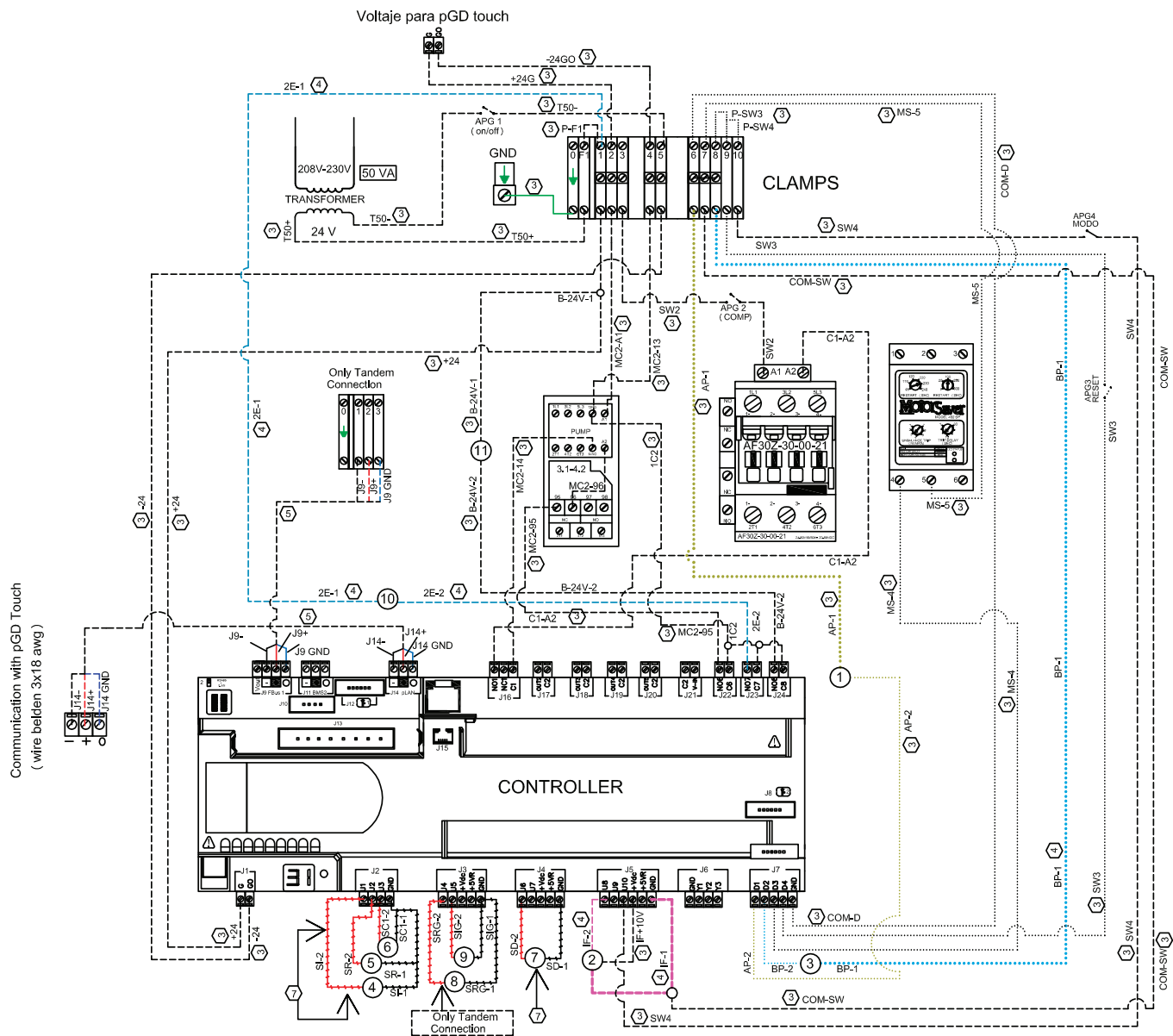

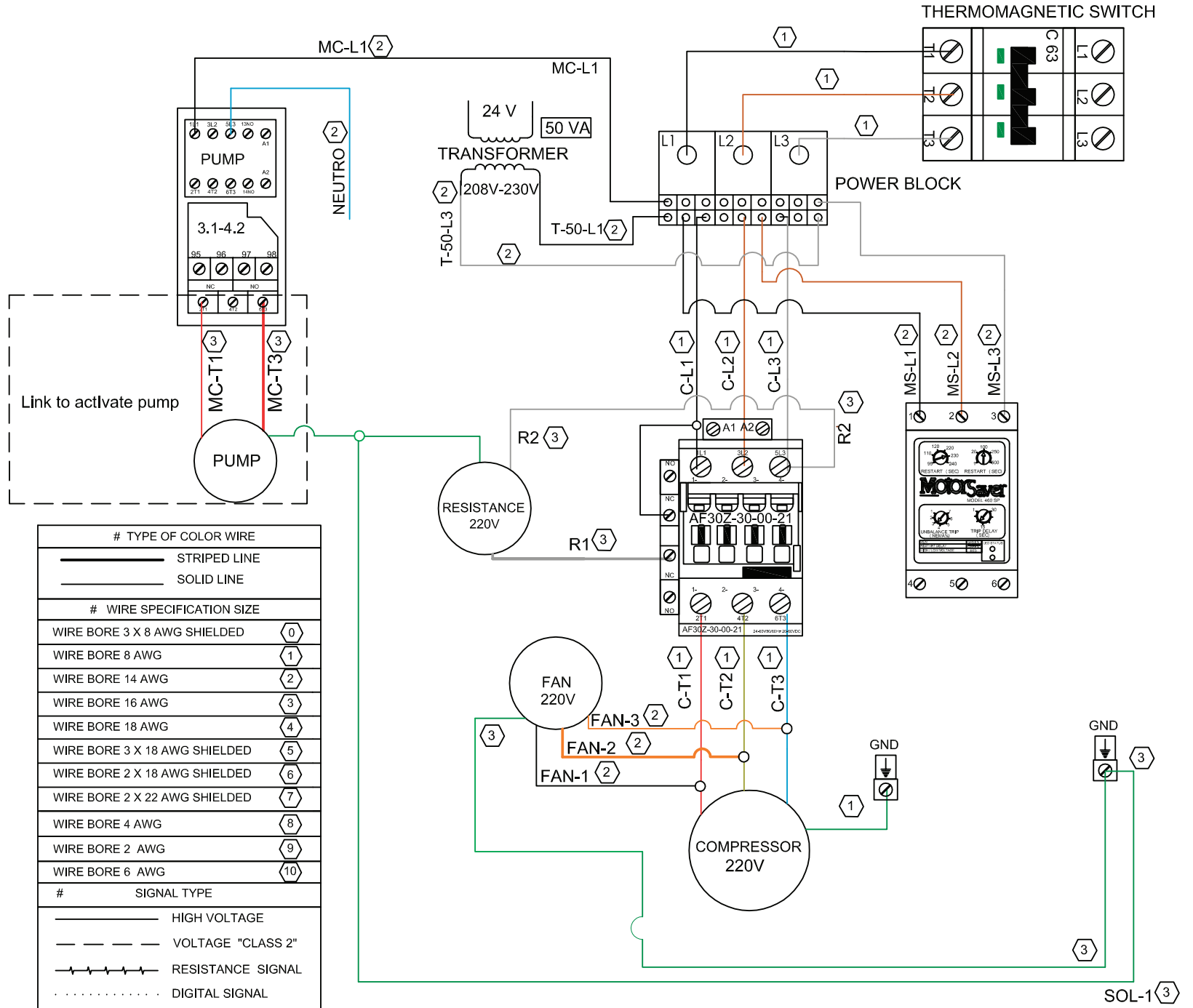





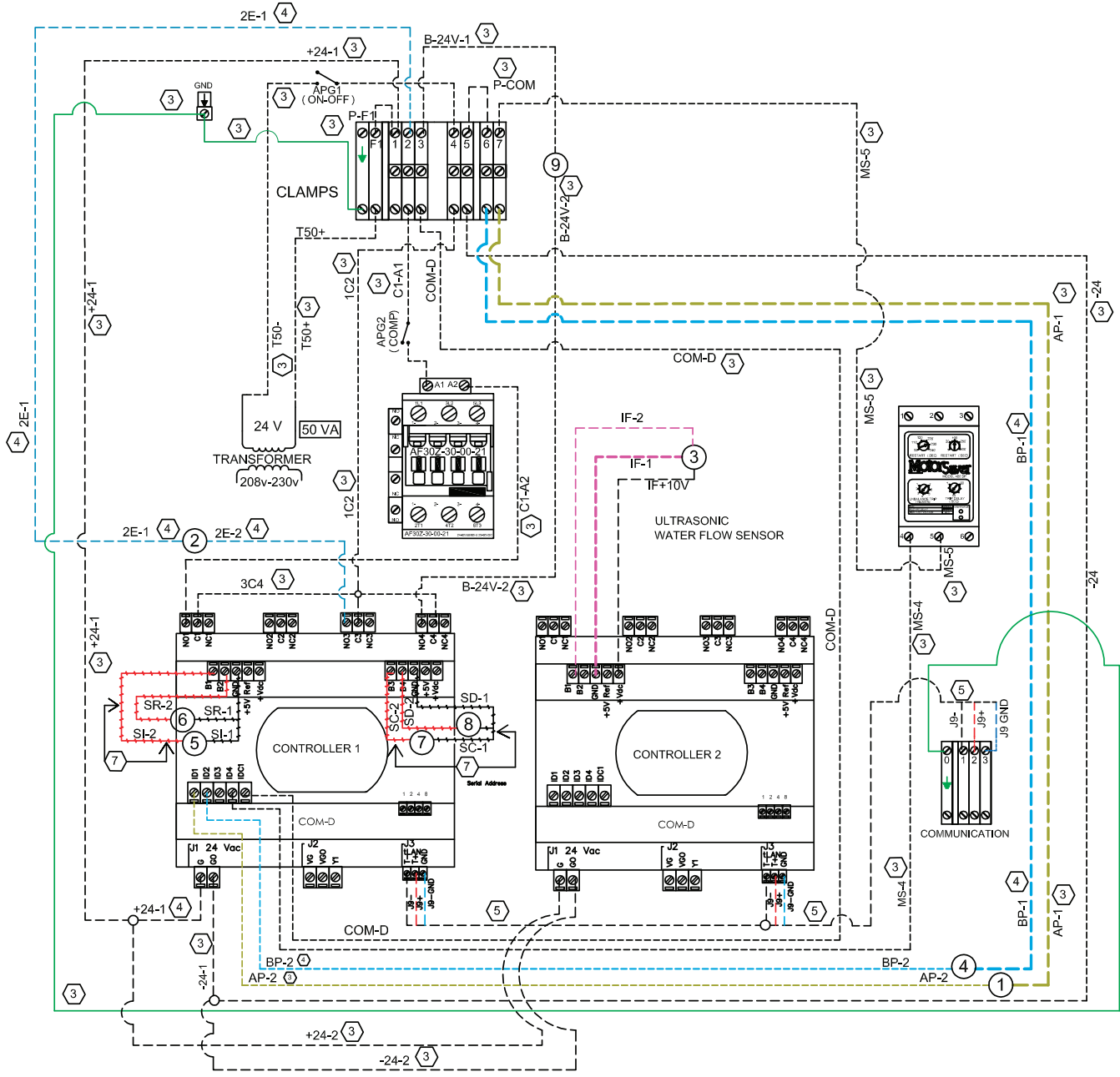

CLV-AGH-060-A3S-S DIAGRAMA DE CONTROL

SIMBOLOGY	
#	CONCEPT
1	HIGH PRESSURE SENSOR
2	SECOND STAGE
3	ULTRASONIC WATER FLOW SENSOR
4	LOW PRESSURE SENSOR
5	OUTLET SENSOR
6	INLET SENSOR
7	FREEZING SENSOR
8	SENSOR CONDENSER
9	THREE WAY REGULATION COIL
# TYPE OF COLOR WIRE	
	STRIPED LINE
	SOLID LINE
# WIRE SPECIFICATION SIZE	
WIRE BORE 3 X 8 AWG SHIELDED	0
WIRE BORE 8 AWG	1
WIRE BORE 14 AWG	2
WIRE BORE 16 AWG	3
WIRE BORE 18 AWG	4
WIRE BORE 3 X 18 AWG SHIELDED	5
WIRE BORE 2 X 18 AWG SHIELDED	6
WIRE BORE 2 X 22 AWG SHIELDED	7
WIRE BORE 4 AWG	8
WIRE BORE 2 AWG	9
WIRE BORE 6 AWG	10
#	SIGNAL TYPE
	HIGH VOLTAGE
	VOLTAGE "CLASS 2"
	RESISTANCE SIGNAL
	DIGITAL SIGNAL

CLASS 2



# TYPE OF COLOR WIRE	
	STRIPED LINE
	SOLID LINE
# WIRE SPECIFICATION SIZE	
WIRE BORE 3 X 8 AWG SHIELDED	0
WIRE BORE 8 AWG	1
WIRE BORE 14 AWG	2
WIRE BORE 16 AWG	3
WIRE BORE 18 AWG	4
WIRE BORE 3 X 18 AWG SHIELDED	5
WIRE BORE 2 X 18 AWG SHIELDED	6
WIRE BORE 2 X 22 AWG SHIELDED	7
WIRE BORE 4 AWG	8
WIRE BORE 2 AWG	9
WIRE BORE 6 AWG	10
# SIGNAL TYPE	
	HIGH VOLTAGE
	VOLTAGE "CLASS 2"
	RESISTANCE SIGNAL
	DIGITAL SIGNAL

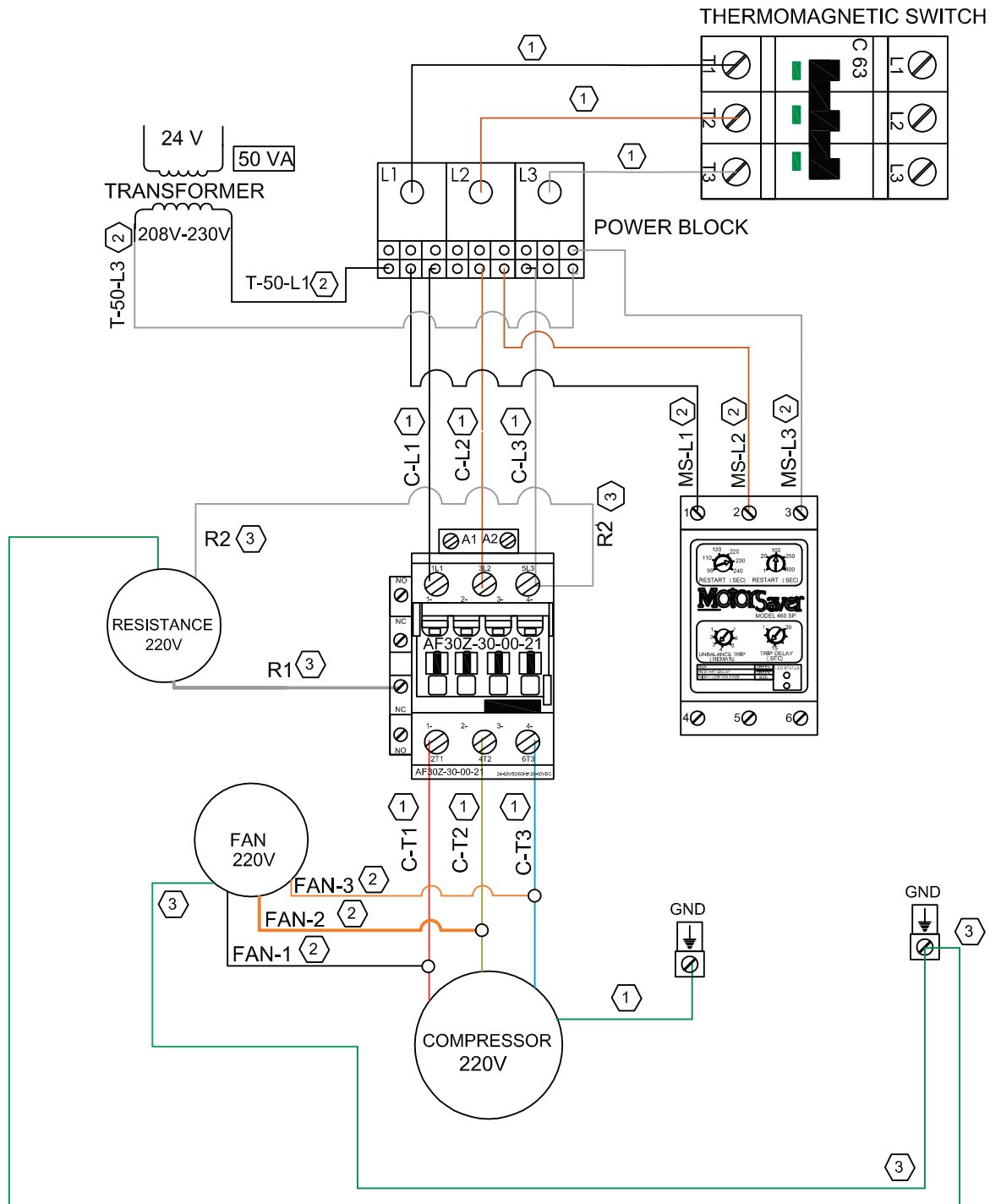



Av. Central No. 285, Parque Logistico,
Deleg. La Pila, San Luis Potosi, C.P. 78422
More Info (444) 161.50.43
info@clima-flex.com
service@clima-flex.com
ventas@clima-flex.com
US Toll Free **01 800 201 48 16**
Lada sin costo **01 800 890 59 17**

