



Air Conditioning



# INSTALLATION MANUAL

*We are leaders in the creation of innovative air conditioning solutions using state of the art technology and world class product design*



SMALL FOOTPRINT

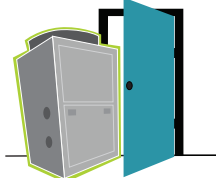

BALANCING VALVE

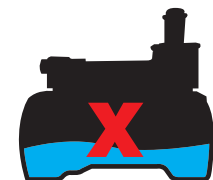

ISOLATION VALVE

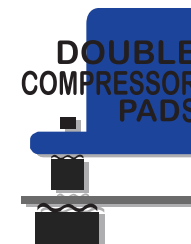

DOUBLE COMPRESSOR PADS



MICROCHANNEL

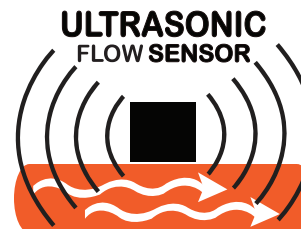

ULTRASONIC FLOW SENSOR



EC FANS

# CLIMA-FLEX | TECHNOLOGIES

This technology may or may not be included in the unit depending on the model

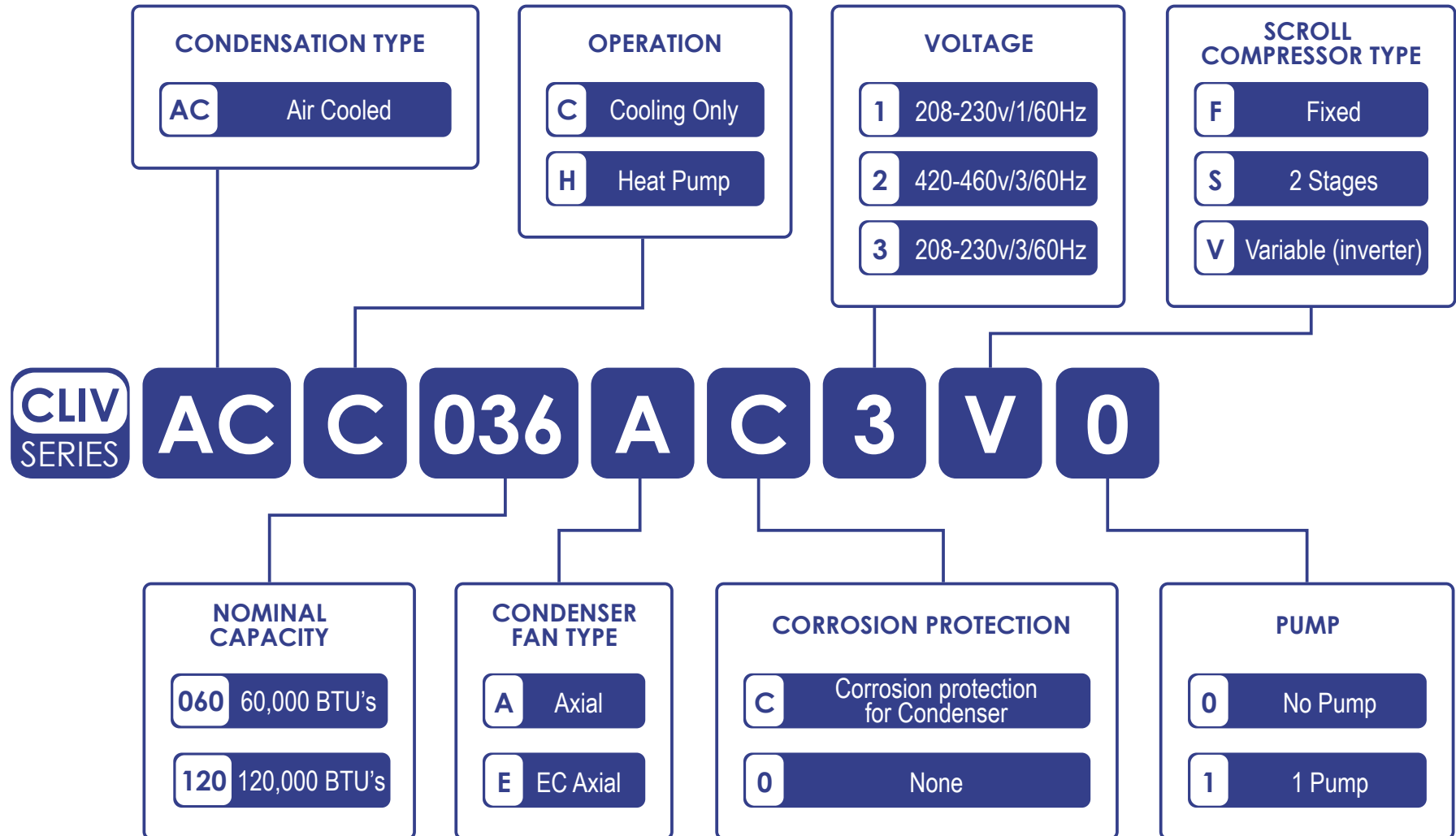

## WARNING - CAUTION - NOTE

## IMPORTANT SAFETY INSTRUCTIONS

This manual contains important safety instructions that should be followed during the installation and maintenance of the unit. Read this manual thoroughly before attempting to install or operate this unit.

Only qualified personnel should service this equipment. Adhere to all warnings, cautions, operating and safety instructions on the unit placards and in this manual. Follow all operating and user instructions during and after installation.

Installer should pay particular attention to the words: **NOTE**, **CAUTION** and **WARNING**. Notes are intended to clarify or make the installation easier. Cautions are given to prevent equipment damage. Warnings are given to alert installer that personal injury and/or equipment damage may result if installation procedure is not handled properly.



Improper installation may create a condition where the operation of the product could cause personal injury or property damage. Improper installation, adjustment, alteration, service, or maintenance can cause injury or property damage. Refer to this manual for assistance or additional information, consult a qualified installer or service agency.

Electrical shock hazard. Disconnect voltage at main panel or power source before opening any cover. Failure to comply may result in injury or death.

To minimize the hazard of electrical shock and personal injury, this component must be effectively grounded. Refer to installation guidelines for further information.



This product must be installed in strict compliance with the enclosed installation instructions and any applicable local, state, and national codes including but not limited to, building, electrical and mechanical codes.

Risk of sharp edges, splinters, and exposed fasteners. Can cause injury.

Only properly trained and qualified personnel wearing appropriate safety headgear, gloves, shoes and glasses should attempt to move the unit, lift it, remove packaging or prepare the unit for installation.

Risk of contact with hot surfaces. Can cause injury.

The compressors, fan motors, refrigerant discharge lines and reheats are extremely hot during unit operation. Allow sufficient time for them to cool before working within the unit cabinet.

Periodically inspect all valves, fittings, and piping for corrosion, rust, leaks, or damage.

This unit uses a microprocessor-based electronic control system. Do not use jumpers or other tools to short out components, or to bypass or otherwise depart from recommended procedures. Any short-ground of the control board or accompanying wiring may destroy the electronic modules or electrical components.

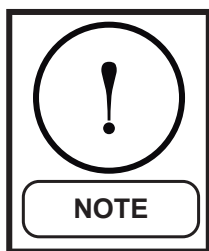

Risk of clogged or leaking drain lines. Can cause equipment and building damage. This unit requires a water drain connection. Drain lines must be inspected regularly and maintenance must be performed to ensure that drain water runs freely through the drain system and that lines are clear and free of obstructions and in good condition with no visible sign of damage or leaks.

This unit may also require an external water supply to operate.

Improper installation, application and service practices can result in water leakage from the unit. Water leakage can result in severe property damage and loss of critical equipment. Do not locate unit directly above any equipment that could sustain water damage.

## • Efficiency

Our units are designed to meet the needs of any project. Our featured intelligent process controllers and smart temperature sensors provide maximum performance while saving energy.

The system automatically modifies the operation mode to maintain optimal conditions, making it very easy to operate.

All temperature sensors are calibrated and set at the factory before shipment. Start up has to be performed by a qualified technician, during the initial startup steps the unit will be set to local conditions and all points of operation will be reviewed.

Once the unit is set, operation is a matter of pressing the start and stop button and making sure that the unit operates properly, after this the unit will operate automatically, starting itself according to the demand of the cooling system and local conditions.

## • Flexibility

The units have smart processors and sensors to automatically control the temperature at optimum operating conditions.

The units were designed to mate with each other and be combined to meet different load variations (tandem installation). You can combine up to 8 modules; these combinations may be done with chillers of different capacities ranging from 3 to 200 tons. Capacity varies depending on the number and type of units.

## • Reliability

All structures are made of galvanized steel sheet, coated with electrostatic baked paint to ensure long durability and no corrosion in any weather, such as prolonged direct sunlight, rain and wind.

All units are designed to fit a reduced installation space, eliminating thus large installation areas. We only use high quality components to ensure durability and reliability even under harsh environmental conditions.

**NOTE:** For applications in tropical climates our units are coated inside and outside with Corrosion Protection.

Our products have efficiency certifications from AHRI and electrical certifications from ETL, we also comply with all industry safety standards. We are members of the American Society of Air Conditioning, Refrigeration and Heating Engineers (ASHRAE). To support our commitment to customers and our stakeholders our units have a 1 year mayor warranty after start up, .

Our units use R410A refrigerant, which is harmless to the ozone layer and is not toxic or flammable, even in case of leakage.

Finally, the heat exchanger efficiency and modular design allow for an easy and quick installation.

## • Design

Research conducted by the Engineering Department have resulted in units with a high design efficiency and optimum performance. The selection of prime components and our quality and control system ensures performance and reliability. All main components are rigorously tested and qualified before being installed. Each unit design has gone through long hours of rigorous testing to ensure reliability, durability and quality of the entire system.

All external paint has been tested in a saline chamber and is rated at 1,500 hours proof. Compressors and heat exchangers ensure high equipment efficiency capacity. The water pump is specially designed to work properly and with minimal vibration and noise.

All units have a compact and sturdy structure while maintaining a slim profile.

## • Communication

The units can be controlled independently as a single unit (individual mode), or they can be connected to a central control unit ("Tandem Mode"). Operation and user input is done via a color 7" touch screen.

Our units can handle different communication protocols; such as Modbus and Bacnet, the most commonly used protocols in the HVAC industry.

Our units keep track of all the programming variables in real time, as well as monitoring performance and specific alarms in the refrigeration cycle, the electrical system as well as external factors such as fire and flood detection (optional sensors).

The control and monitoring system ensures the proper operation of the unit by monitoring in real time the health of all major components (high and low refrigerant pressure, compressors and fan motors health, etc).

In case of a malfunction the event will be recorded for later analysis, facilitating the location of the possible failure and its solution.

## • Installation

The units have been designed for a field-friendly installation. Screw type connections provide easy installation of the water pipes, said connections are located on both sides of the unit, so that the pipes can be connected on either side of the equipment.

The individual assembly of the units reduces installation costs on site, the units have a rigid base which bears the weight of the unit and allows an easy installation.

## • Maintenance

The simplicity in the design of each unit allows maximum ease in maintenance. All major components are available to maintenance personnel by opening the service panel. If an emergency stop occurs, the control section will indicate the detailed cause of the failure, helping to accelerate and facilitate the solution process.

## • Factory Testing

Each unit is pressure and vacuum tested, then charged with the refrigerant required for proper operation based on the client installation conditions.

The units are then evaluated at full load operation with water flow, thermal load and line voltage set to the actual conditions in which the equipment will operate. Finally the units are performance tested at application temperatures ranging from -10 °C to 45+ °C.

**NOTE:** The warranty policy requires that the start up be made by qualified and authorized personnel.

Units are built with control and design in mind, assembled with technically specialized control software. Some of our features are in house production of all piping and wiring, scroll type compressors, new generation evaporators, air cooled condensers, optional hydraulic components, and several safety and security protections. Our units are ecofriendly and operate with R-410A refrigerant.

## • Compressor

Our two-stage, fixed scroll, digital and variable compressors have better liquid handling properties. Because of its axial and radial shape, it allows parts of the scroll to be separated in the presence of coolant, thus offering protection against liquid damage.

They are more efficient over the full operating range, operating at sound levels and lower vibration than traditional compressors, it has 70% fewer moving parts, startability under any load on the system, without removing components, easy service and maintenance due to its compact size and lightweight and simple design, built to achieve optimum performance with current refrigerants without chlorine, without complex internal suction valves and discharge for quieter operation and increased reliability.

## • Evaporator

The plate heat exchanger is made of stainless steel plates welded together closely to ensure high efficiency heat exchange. The heat exchanger is insulated with a flexible elastomer of a minimum thickness of 1/2" to provide optimal thermal insulation.

The microchannel technology allows to optimize the use of refrigerant, both in the condenser and throughout the cooling cycle. This is a series of flat tubes (microchannels), through which the refrigerant circulates. Heat transfer is maximized by these extremely thin tubes, optimizing the system, providing significant savings in the use of refrigerant gas.

## • Thermostatic Expansion Valve

The Thermostatic Expansion Valve (TEV) keeps the evaporator stocked with sufficient refrigerant to meet load conditions. It has no way to turn on or off the compressor, but keeps the superheated refrigerant itself in the suction line of the compressor. The thermostatic expansion valve installed in each circuit has been selected for a range of specific operation conditions.

## • Filter-Drier

The dehydrator filter is designed to keep the circuit clean and remove residual moisture from the refrigerant circuit and avoid affecting the operation of the unit by acidification of the oil, which causes slow disintegration of the varnish that protects the motor windings in the compressor.

## • Fan

To carry out air injection the units have axial and centrifugal type fans, which are directly driven by single-phase and/or three-phase motors. The fans are weatherproof to ensure continuous operation.

## • Expansion Tank (optional)

Used in the system to handle the volume variations of the liquid contained in the pipe system due to temperature changes.

## • Balancing Valve

This balancing valve is placed in the unit in order to control and maintain a constant water flow in the circuit, with the special feature that the flow can be adjusted anytime as needed.

## • Temperature Sensor

Through digital signals generated by these devices the temperature is measured accurately and in real time.

## COMPONENTS

### • Refrigeration controls

The units are equipped with solenoid valves, expansion valves, dehydrator, and service valves.

### • Electrical components

All units are equipped with a control panel, security anti-theft devices, internal and external overheating protection, compressor drive protection, flow protection, freezing protection and electrical failure protection. The control panel has LED operation indicating lights. Depending on the model some other indicators may be installed.

## HYDRAULIC COMPONENTS (OPTIONAL)

### • Water pump

The drive in the water pump is TEFC (Totally Enclosed Fan Cooled) and has anti-corrosive coating on the housing.

## CONTROL

The control unit allows the connection of the unit to the INTERNET, and allows the user to visualize all the unit's operating information, such as variable graphics, tendencies cycle time, diagnosis of components, alarms, etc. Access to this information renders a more efficient operation and system control.

## CONNECTIVITY

The connectivity via internet enables our units to operate remotely, to check the status of their maintenance cycle and remedy any situation quickly and efficiently.

## VRW

This units are pioneers in the VRW technology. The most important advantages are no loss of performance tonnes over distance, uses water as heat medium, requires no special installation, far better performance at a lower cost.



# CORROSION PROTECTION (OPTIONAL)

The inorganic film on the surface is ultra thin and is formed by an inert ceramic glass layer that is obtained at ambient temperatures. This innovative technology provides:

- UV resistance
- A crystalline finished, non-yellowing
- Positively charged coating to repel H<sub>2</sub>O
- Magnificent luster and depth of image retention
- Outstanding resistance to solvents and chemicals
- Exceptional abrasion resistance

## • Energy Efficient

With Corrosion Protection you save energy between 9% to 15%. Its sealant layer of only 3-5 microns allows heat transfer be more efficient.

## • Extends the life of the equipment

Corrosion Protection extends the life of your air conditioner units, refrigerators or cooling towers, because it protects up to for 5 years, preserving its appearance and function.

Corrosion Protection is applied to cabinets, capacitors, grids and coils, achieving great benefits and durability that can not be obtained with conventional protections.



## ANALOGUE POINTS

CODE	BMS MODBUS ADDRESS	MODBUS FUNCTION TYPE READ
Temp_Cabezal_out	56	AnalogInput
Temp_Cabezal_in	55	AnalogInput
Temp_iny_Maestro	52	AnalogInput
Temp_ret_Maestro	53	AnalogInput
Temp_cong_Maestro	54	AnalogInput
Temp_Conden_M	57	AnalogInput
Temp_iny_E1	65	AnalogInput
Temp_ret_E1	66	AnalogInput
Temp_cong_E1	67	AnalogInput
Temp_Conden_E1	68	AnalogInput
Temp_iny_E2	70	AnalogInput
Temp_ret_E2	71	AnalogInput
Temp_cong_E2	72	AnalogInput
Temp_Conden_E2	73	AnalogInput
Temp_iny_E3	75	AnalogInput
Temp_ret_E3	76	AnalogInput
Temp_cong_E3	77	AnalogInput
Temp_Conden_E3	78	AnalogInput
Temp_iny_E4	80	AnalogInput
Temp_ret_E4	81	AnalogInput
Temp_cong_E4	82	AnalogInput
Temp_Conden_E4	83	AnalogInput
Modulate_Power_Req	89	AnalogInput
Variador	64	AnalogInput
H_Horas_CompM	5057	AnalogInput
L_Horas_CompM	5058	AnalogInput
H_Arranques_CompM	5059	AnalogInput
L_Arranques_CompM	5060	AnalogInput
H_BP_CompM	5063	AnalogInput
L_BP_CompM	5064	AnalogInput
H_AP_CompM	5061	AnalogInput
L_AP_CompM	5062	AnalogInput
H_Horas_BombaM	5065	AnalogInput
L_Horas_BombaM	5066	AnalogInput
H_Arranques_BombaM	5067	AnalogInput
L_Arranques_BombaM	5068	AnalogInput
H_Horas_CompE1	5069	AnalogInput
L_Horas_CompE1	5070	AnalogInput
H_Arranques_CompE1	5071	AnalogInput
L_Arranques_CompE1	5072	AnalogInput
H_BP_CompE1	5075	AnalogInput
L_BP_CompE1	5076	AnalogInput
H_AP_CompE1	5073	AnalogInput

CODE	BMS MODBUS ADDRESS	MODBUS FUNCTION TYPE READ
L_AP_CompE1	5074	AnalogInput
H_Horas_BombaE1	5077	AnalogInput
L_Horas_BombaE1	5078	AnalogInput
H_Arranques_BombaE1	5079	AnalogInput
L_Arranques_BombaE1	5080	AnalogInput
H_Horas_CompE2	5081	AnalogInput
L_Horas_CompE2	5082	AnalogInput
H_Arranques_CompE2	5083	AnalogInput
L_Arranques_CompE2	5084	AnalogInput
H_BP_CompE2	5087	AnalogInput
L_BP_CompE2	5088	AnalogInput
H_AP_CompE2	5085	AnalogInput
L_AP_CompE2	5086	AnalogInput
H_Horas_BombaE2	5089	AnalogInput
L_Horas_BombaE2	5090	AnalogInput
H_Arranques_BombaE2	5091	AnalogInput
L_Arranques_BombaE2	5092	AnalogInput
H_Horas_CompE3	5093	AnalogInput
L_Horas_CompE3	5094	AnalogInput
H_Arranques_CompE3	5095	AnalogInput
L_Arranques_CompE3	5096	AnalogInput
H_BP_CompE3	5099	AnalogInput
L_BP_CompE3	5100	AnalogInput
H_AP_CompE3	5097	AnalogInput
L_AP_CompE3	5098	AnalogInput
H_Horas_BombaE3	5101	AnalogInput
L_Horas_BombaE3	5102	AnalogInput
H_Arranques_BombaE3	5103	AnalogInput
L_Arranques_BombaE3	5104	AnalogInput
H_Horas_CompE4	5105	AnalogInput
L_Horas_CompE4	5106	AnalogInput
H_Arranques_CompE4	5107	AnalogInput
L_Arranques_CompE4	5108	AnalogInput
H_BP_CompE4	5111	AnalogInput
L_BP_CompE4	5112	AnalogInput
H_AP_CompE4	5109	AnalogInput
L_AP_CompE4	5110	AnalogInput
H_Arranques_BombaE4	5115	AnalogInput
L_Arranques_BombaE4	5116	AnalogInput
H_Horas_BombaE4	5113	AnalogInput
L_Horas_BombaE4	5114	AnalogInput
Inverter_Power_Min	19	Holding
Setpoint_enf	10	Holding
Setpoint_cal	92	Holding

CODE	BMS MODBUS ADDRESS	BACNET ADDRESS	MODBUS FUNCTION TYPE READ
AI_Fases_M	3	0	Coil
AI_Baja_pres_CM	4	1	Coil
AI_Alta_pres_CM	5	3	Coil
AI_congelamiento_M	6	4	Coil
AI_flujoM	9	5	Coil
AI_Fases_E1	26	6	Coil
AI_Baja_pres_E1	27	7	Coil
AI_Alta_pres_E1	28	8	Coil
AI_congelamiento_E1	29	9	Coil
AI_flujoE1	32	10	Coil
AI_Fases_E2	41	11	Coil
AI_Baja_pres_E2	42	12	Coil
AI_Alta_pres_E2	43	13	Coil
AI_congelamiento_E2	44	14	Coil
AI_flujoE2	47	15	Coil
AI_flujo_Cond_E2	48	16	Coil
AI_Fases_E3	56	17	Coil
AI_Baja_pres_E3	57	18	Coil
AI_Alta_pres_E3	58	19	Coil
AI_congelamiento_E3	59	20	Coil
AI_flujoE3	62	21	Coil
AI_Fases_E4	71	22	Coil
AI_Baja_pres_E4	72	23	Coil
AI_Alta_pres_E4	73	24	Coil
AI_congelamiento_E4	74	25	Coil
AI_flujoE4	77	26	Coil
AI_E1_Offline	80	27	Coil
AI_E2_Offline	81	28	Coil
AI_E3_Offline	82	29	Coil
AI_E4_Offline	83	30	Coil
AI_EAux1_Offline	84	31	Coil
on_off2	85	32	Coil
AI_Sens_Flujo_M	94	33	Coil
AI_EAux2_Offline	100	34	Coil
Reset_Als	112	35	Coil
AI_Sens_Flujo_E1	126	36	Coil
AI_Sens_Flujo_E2	127	37	Coil
AI_Sens_Flujo_E3	131	38	Coil
AI_Sens_Flujo_E4	132	39	Coil
ON_OFF (estado)	143	40	DigitalInput
ED_sensor_flujo_Maestro	164	41	DigitalInput
ED_Monitor_Fases_Maestro	165	42	DigitalInput
ED_Baja_Pres_Maestro	166	43	DigitalInput
ED_AP_Maestro	167	44	DigitalInput
on_off3 ( entrada)	168	45	DigitalInput
ED_selector	169	46	DigitalInput
ED_AP_E1	192	47	DigitalInput
ED_Baja_Pres_E1	193	48	DigitalInput
ED_Monitor_Fases_E1	194	49	DigitalInput
ED_sensor_flujo_E1	195	50	DigitalInput

CODE	BMS MODBUS ADDRESS	BACNET ADDRESS	MODBUS FUNCTION TYPE READ
ED_AP_E2	197	51	DigitalInput
ED_Baja_Pres_E2	198	52	DigitalInput
ED_Monitor_Fases_E2	199	53	DigitalInput
ED_sensor_flujo_E2	200	54	DigitalInput
ED_AP_E3	202	55	DigitalInput
ED_Baja_Pres_E3	203	56	DigitalInput
ED_Monitor_Fases_E3	204	57	DigitalInput
ED_sensor_flujo_E3	205	58	DigitalInput
ED_AP_E4	207	59	DigitalInput
ED_Baja_Pres_E4	208	60	DigitalInput
ED_Monitor_Fases_E4	209	61	DigitalInput
ED_sensor_flujo_E4	210	62	DigitalInput
CompMaes	212	63	DigitalInput
BombaM	214	64	DigitalInput
Ventilador_M	215	65	DigitalInput
Comp_E1	216	66	DigitalInput
Ventilador_E1	218	67	DigitalInput
Valv_rev_M	219	68	DigitalInput
BombaE2	221	69	DigitalInput
Ventilador_E2	222	70	DigitalInput
Comp_E3	223	71	DigitalInput
Ventilador_E3	225	72	DigitalInput
Comp_E4	226	73	DigitalInput
Ventilador_E4	228	74	DigitalInput
Modo_B_C	236	75	Coil
AI_Agua_Helada_M	238	76	Coil
AI_Agua_Helada_E1	239	77	Coil
AI_Agua_Helada_E2	240	78	Coil
AI_Agua_Helada_E3	241	79	Coil
AI_Agua_Helada_E4	242	80	Coil
Falla_Cont_Cong_M	247	81	Coil
Falla_Cont_Cong_E1	248	82	Coil
Falla_Cont_Cong_E2	249	83	Coil
Falla_Cont_Cong_E3	250	84	Coil
Falla_Cont_Cong_E4	251	85	Coil
Term_Ch_BC	253	86	Coil
ED_Humo	261	87	Coil
ED_Incendio	262	88	Coil
ED_Inundacion	263	89	Coil
Alarma_Humo	268	90	Coil
Alarma_Incendio	269	91	Coil
Alarma_Inundacion	270	92	Coil
AI_EAux3_Offline	303	93	Coil
AlarmMantCM	304	94	Coil
AlarmMantBM	305	95	Coil
AlarmMantCE1	306	96	Coil
AlarmMantBE1	307	97	Coil
AlarmMantCE2	308	98	Coil
AlarmMantBE2	309	99	Coil

## POWER LINES CONNECTION

**NOTE:** Remember to tighten fasteners well at the end of installation.

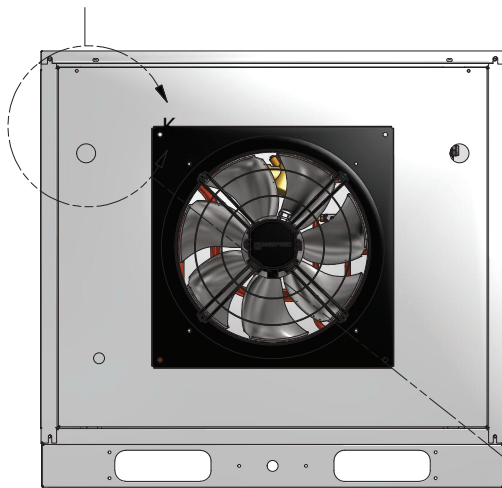

**VISTA  
FRONTAL**

**VISTA  
ISOMÉTRICA**

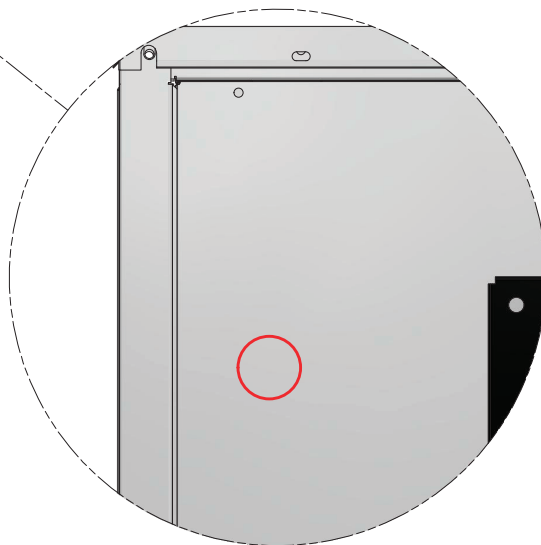
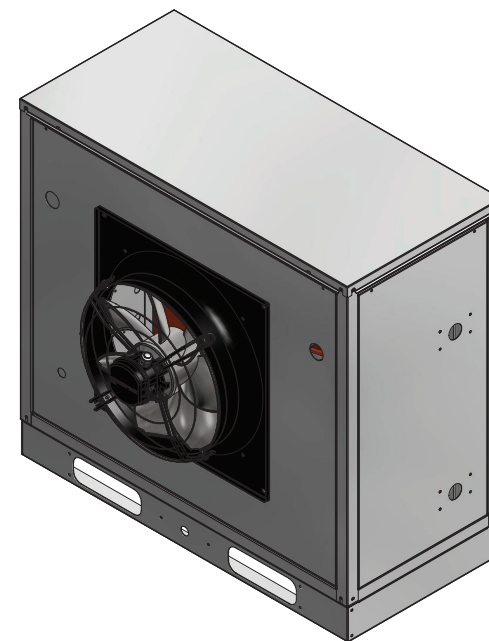

El cable de alimentación de corriente hacia nuestro módulo deberá instalarse por la parte señalada (Ver imagen de detalle)

## • INSTRUCTIONS FOR ELECTRICAL CONDUIT

1. Before starting the electrical connection of your equipment make sure that the main switch and the switch of your equipment are de-energized.
2. Remove the knockouts from your equipment with a hammer and chisel.
3. Remove the nut from its liquid tight 90 ° curved connector 1 ".
4. Make sure that the packing of its connector is in position before placing the connector.
5. The connector must be positioned 90 ° with the cable entry to the bottom. Channel with hose up to the main switch.

**NOTE 1:** Clima Flex does not include connectors or accessories for electrical interconnection.

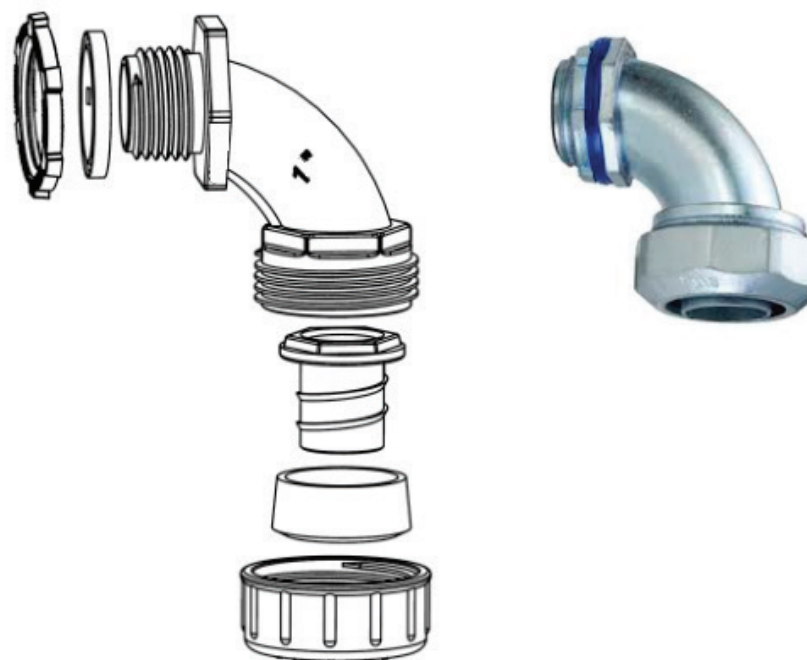

## • LOCATION

The units must be installed in accordance with all national and local safety codes. If no local codes apply, installation must conform to the appropriate national codes.

These Units are designed to be installed in exteriors. It is necessary that the unit has air venting, and a free air intake (see Fig. 13) to allow for good air circulation and allow access for maintenance.

For fully functioning, the units only require the connection with the hydraulic local net and power supply connection in accordance with technical data sheet.

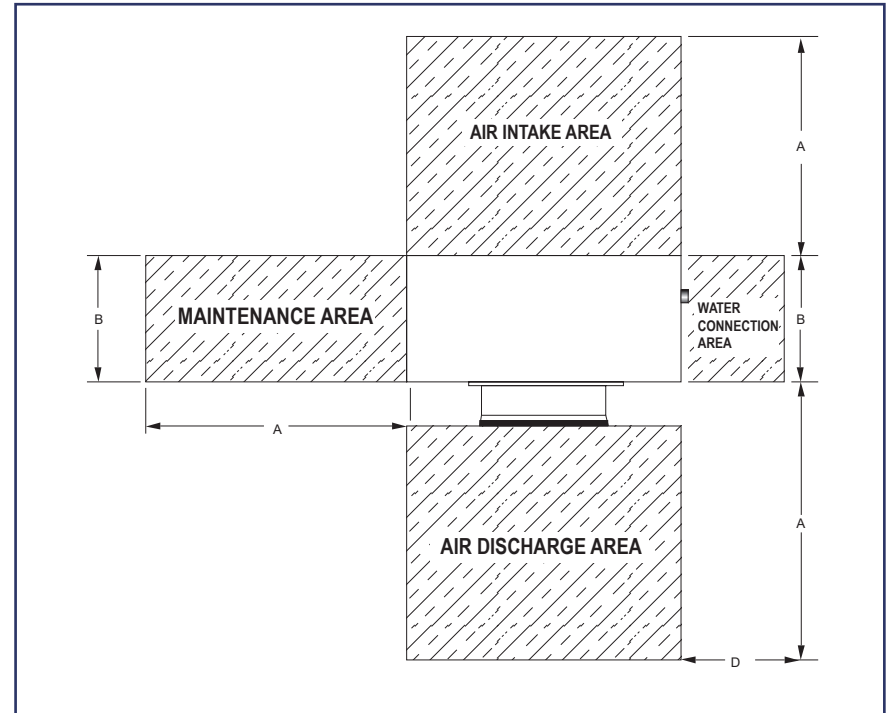

Fig. 13, Recommended unit clearances.



To keep warranty this unit must be installed by trained personnel with expertise on water chillers installation.

DIMENSIONS							
A		B		C		D	
in	cm	in	cm	in	cm	in	cm
39.5	100	27.06	68.73	20.6	50.95	9.5	100

## • LOCATION

The unit must be installed on a solid, perfectly level base. For earthing purposes, a solid cement base, that is wider than the unit, must be made. This base must be able to support the weight of the unit. Anti-vibration supports must be installed between the frame of the unit and the cement base of the steel beams; for such installation follow the dimensional drawing supplied with the unit. The frame of the unit must be perfectly levelled during installation, if necessary using shims to be inserted under the the anti-vibration supports.

If the unit is installed in places that are easily accessible to people and animals, we recommend that protection grates be fitted all round to prevent access. To ensure optimal performance in installation site, the following precautions and instructions must be respected:

- Make sure that there is a strong, solid foundation to reduce noise and vibrations.
- Avoid installing the unit in areas that could be dangerous during maintenance operations, such as platforms without handrails, guide rails or in areas that fail to comply with requirements as regards free space around the unit.

The installer is responsible for calculating the best position for the unit. It is vital that all minimum distances for all units are complied with to ensure there is adequate ventilation for the condenser racks.

- When deciding where to position the unit and to ensure proper airflow, the following factors must be taken into consideration:
- Avoid the recirculation of hot air
- Avoid insufficient air supply for the air cooling condenser. Both these conditions can cause an increase in condenser pressure which can lead to poor energy efficiency and refrigerating capacity.



When lifting the unit, please keep the unit stable and without tilting.

The noise generated by the unit is mainly due to the rotation of compressors.

The noise level for each model size is listed in the documentation.

If the unit is correctly installed, operated and maintained, noise emission levels do not require any special protective devices to operate continuously close to the unit without any risk.

In case of installation with special noise requirements it may be necessary to install additional noise softening devices.

When transporting the unit, it is recommendable to use a forklift or crane to lift it. All units have lifting points. Only these points may be used for lifting the unit, as shown in the Fig. 14.

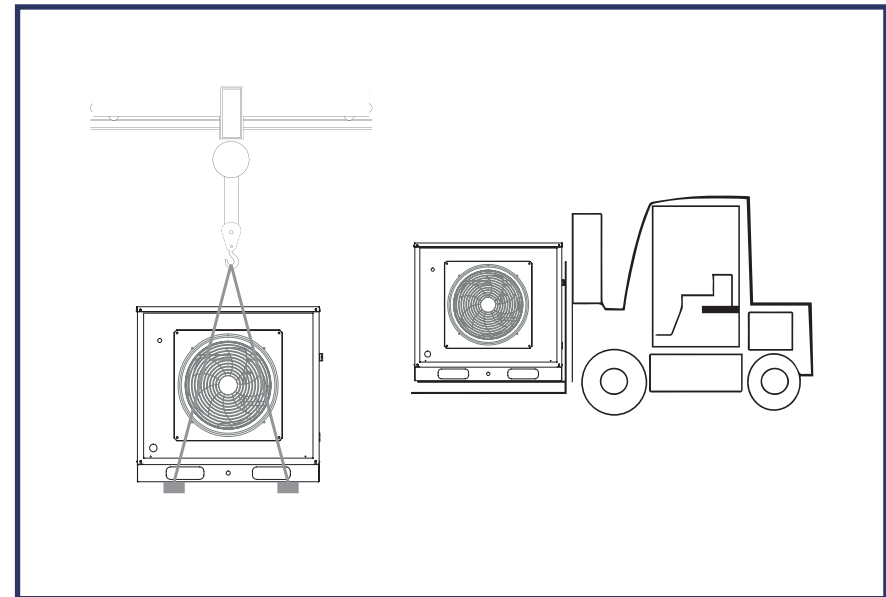

Fig. 14 - Use a crane to lift units..

## • LOCATION

The unit must be inspected for any possible damage immediately upon reaching the final site of installation. All components described in the delivery note must be inspected and checked. Should there be evidence of damage, do not remove the damaged components and immediately report the extent and type of damage both to the transportation company and the manufacturer's representative, sending if possible photos which may be useful in identifying those responsible for the damage.

Damage must not be repaired before the inspection of the transportation company representative and the manufacturer's representative. Before installing the unit, check that the model and power supply voltage shown on the nameplate are correct. The manufacturer will not accept responsibility for any damage following acceptance of the unit.

Provide enough space around the outdoor unit to allow the installation and maintenance personnel unrestricted access to all service points. Refer to submittal drawings for the unit dimensions. A minimum of 1 meter is recommended for compressor service. Provide sufficient clearance for the opening of control panel doors. Refer to Figure 13 for minimum clearances. In all cases, local codes which require additional clearances will take precedence over these recommendations.



### **Heavy Objects!**

Ensure that all the lifting equipment used is properly rated for the weight of the unit being lifted. Each of the cables (chains or slings), hooks, and shackles used to lift the unit must be capable of supporting the entire weight of the unit. Lifting cables (chains or slings) may not be of different length. Adjust as necessary for even unit lift. Other lifting arrangements could cause equipment or property damage. Failure to follow the instructions above or to properly lift the unit could result in unit dropping and possibly crushing operator/technician which could result in death or serious injury.

All wiring must comply with local codes and the National Electric Code. Typical field wiring diagrams are included at the end of the manual. Minimum circuit ampacities and other unit electrical data are on the unit nameplate. See the unit order specifications for actual electrical data. Specific electrical schematics and connection diagrams are shipped with the unit.



### **Proper Field Wiring and Grounding Required!**

All field wiring **MUST** be performed by qualified personnel. Improperly installed and grounded field wiring poses **FIRE** and **ELECTROCUTION** hazards. To avoid these hazards, you **MUST** follow requirements for field wiring installation and grounding as described in NEC and your local/state electrical codes. Failure to follow code could result in death or serious injury.





# WARNING

- All field wiring must be installed in accordance with the national wiring regulation.
- All the terminals and connections must be tightened. Improper connection and fastenings could cause electric shock, short circuit and fire.
- Ensure that the rated voltage of the unit corresponds to that of the name plate before commencing wiring work according to the wiring diagram.
- The unit must be **GROUND**ED to prevent possible hazards due to insulation failure.
- All electrical wiring must not touch the refrigerant piping, compressor, pump, fan motor or any moving parts of the fan motors.
- Do not operate the chiller with wet hands. It could result in electric shock.
- Do not use fuse of different amperage than stated. Using wire etc. to replace a fuse could cause equipment damage or fire.
- Do not allow water to remain in the water pipes if the unit is not operating for a long period. Water must be drained out if the unit is not running during winter. Failing to do so would cause the pipe to freeze and crack.
- Do not drink the chilled water of the unit.

## PREPARING AND CHECKING THE WATER CIRCUIT CONNECTION

The units have a water input and output for the connection of the chiller to water circuit of the system.

This circuit must be connected to the unit by an authorized technician and must comply with all the current national and local regulations on the subject.

The components listed below are not included with the unit, but are supplied upon request, also if their installation is compulsory.

If dirt penetrates the water circuit, there could be problems. Therefore always remember the following when connecting the water circuit:

1. Only use pipes that are clean inside.
2. Keep the end of the pipe facing downward when removing any burrs.
3. Cover the end of the pipe when inserting it through a wall to avoid dust and dirt getting in
4. Clean the pipes of the system located between the filter and the unit, with running water, before connecting it to the system.



The water pressure must not exceed the maximum operating pressure for the unit.

## • PROCEDURE OF VACUUM AND REFRIGERANT CHARGE

Every system that has been exposed to the atmosphere should be properly dehydrated. That is possible if we accomplish appropriate evacuation.

To make a proper evacuation, it is necessary to have a VACUUM PUMP (not compressor) and a vacuum gauge.

The procedure is the following:

- First the access points to the system must be defined. Use the service valves in the outdoor unit on both the drop and the discharge sides (liquid line). That is, high-pressure valve connected to the piping of smaller diameter and the low-pressure valve connected in the piping of larger diameter.
- Only then is it possible to evacuate the system. Basically, we can do in two ways:

\* Method of Dilution

Turn on the vacuum pump and make the vacuum in the pump (valve 1 shut).

Open valve 1 and let the system evacuate until it reaches at least 500 microns. To obtain the measure, close valve 1 and open valve number 2, allowing the vacuum gauge to feel the system pressure. After reaching 500 microns, isolate the vacuum pump and open valve 3, letting the Nitrogen in to break the vacuum. Isolate the Nitrogen cylinder.

Purge the Nitrogen through the connection that links the copper passage to valve 3.



Never disconnect the copper tube of valve 3; just loosen the connection to purge the nitrogen

Repeat the procedure at least twice, doing in the last stage the third evacuation.

At the end of this process, at least 200 microns should be obtained.

In order to obtain a precise reading of vacuum one should isolate the vacuum pump from the system. Close valve 1 and wait about 15 to have a precise measure. If the reading doesn't remain steady either the system still contains humidity or there must be a leakage. Always verify all the connections (points 1, 3 and valves).

\* High Vacuum Method

It is applied with a vacuum pump capable to reach vacuum lower than 500 microns in only one evacuation. Proceed as follows:

1. Turn on the vacuum pump, then open valve 1 (fig 15). Later on, isolate the vacuum pump and open the valve.

2. When a reading lower than 500 microns is obtained (try to reach the lowest possible value), the vacuum procedure will have been completed.



The pump oil should be replaced periodically in order to guarantee the vacuum efficiency.

### REFRIGERANT CHARGE

After evacuating the system appropriately, close the valves of the manifold and isolate the vacuum pump, the vacuum gauge and the Nitrogen cylinder.

To do the refrigerant charge, replace the Nitrogen cylinder shown in Fig. 15 with a refrigerant cylinder. Purge the hose that links the cylinder to the service valve.

Open the service valve which gives access to the refrigerant cylinder and then the high-pressure valve of the manifold.

To load the system appropriately, verify in the identification labels of the units the amount of refrigerant that should be added to the system.

With the system shut down, load the refrigerant in liquid form through the service valve of liquid line (smaller diameter).

For help, use a scale (if not using a graduate cylinder). Allow at least 10 minutes before turning the unit back on.

Close the discharge valve of the manifold, open the suction valve and with the system in operation complete the charge with refrigerant in gas form (between 5% and 20% the total). Check in the scale the refrigerant weight added to the system. When the charge is complete close the suction valve of the manifold, disconnect the suction and discharge hoses. Close the cylinder valve.

The charge procedure will be complete.

### REFRIGERANT WITHDRAWAL

If for any reason there is need to remove/lose refrigerant, the service valves of these units allow to remove refrigerant from the system into the outdoor unit.

Procedure:

Step 1: Connect manifold hoses to the vents of the outdoor unit service valves.

Step 2: Close the service valve of 1/4" liquid line.

Step 3: Turn on the unit in cooling mode until that the system pressure reaches 2 psig. Then, close the service valve of the suction line 3/8 " so that the refrigerant gas remains withdrawn.

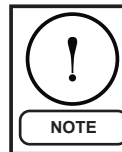

The refrigerant must be adjusted a 20% in order to reach the evaporation temperature. You can check the charge in the next page.

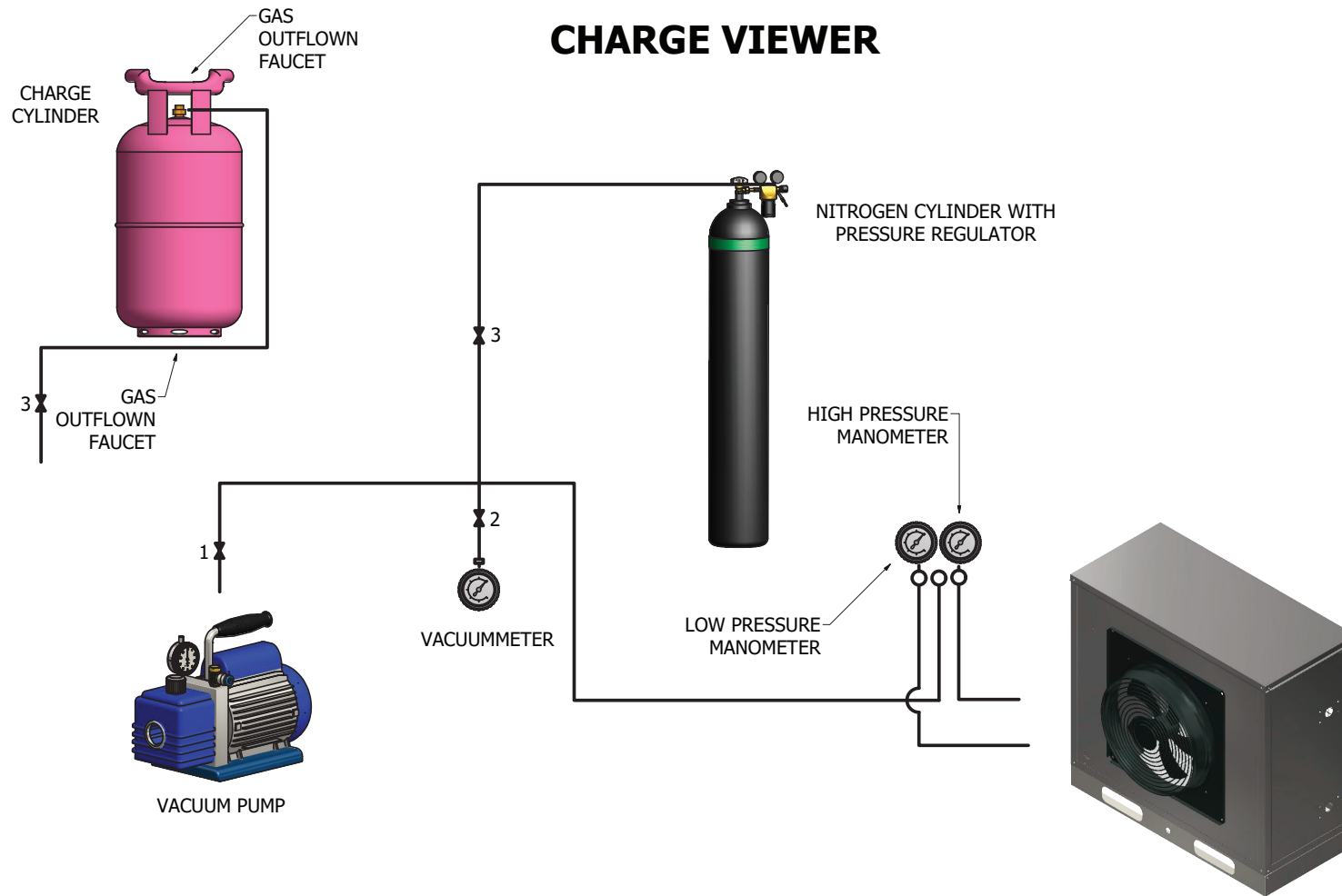

*CHART FOR OBTAINING VACUUM AND FOR REFRIGERANT CHARGING*

<b>REFRIGERANT CHARGE</b>				<b>PRESSURE RANGE</b>	
<b>MODEL</b>	<b>TR</b>	<b>Refrigerant (Lbs)</b>	<b>Refrigerant (Kg)</b>	<b>HI PRESSURE</b>	<b>LOW PRESSURE</b>
CLIV	5	3.5-5	1.6-2.3	340-370 psi	115-125 psi
CLIV	10	5.5-7	2.5-3.1	340-370 psi	115-125 psi

# PRESSURE - TEMPERATURE TABLE

Saturation conditions

°C	°F	R-410A
-45	-49.0	6.4
-44	-47.2	7.5
-43	-45.4	8.4
-42	-43.6	10.1
-41	-41.8	10.5
-40	-40.0	11.6
-39	-38.2	12.7
-38	-36.4	13.9
-37	-34.6	15.2
-36	-32.8	16.5
-35	-31.0	17.8
-34	-29.2	19.1
-33	-27.4	20.6
-32	-25.6	22.0
-31	-23.8	23.5
-30	-22.0	25.1
-29	-20.2	26.7
-28	-18.4	28.4
-27	-16.6	30.1
-26	-14.8	31.8
-25	-13.0	33.7
-24	-11.2	35.5
-23	-9.4	37.5
-22	-7.6	39.5
-21	-5.8	41.5
-20	-4.0	43.7
-19	-2.2	45.8
-18	-0.4	48.1
-17	1.4	50.4

°C	°F	R-410A
-16	3.2	52.8
-15	5.0	55.2
-14	6.8	57.7
-13	8.6	60.3
-12	10.4	62.9
-11	12.2	65.7
-10	14.0	68.5
-9	15.8	71.3
-8	17.6	74.3
-7	19.4	77.3
-6	21.2	80.4
-5	23.0	83.6
-4	24.8	86.9
-3	26.6	90.2
-2	28.4	93.7
-1	30.2	97.2
0	32.0	100.8
1	33.8	104.5
2	35.6	108.3
3	37.4	112.2
4	39.2	116.2
5	41.0	120.3
6	42.8	124.5
7	44.6	128.8
8	46.4	133.1
9	48.2	137.6
10	50.0	142.2
11	51.8	146.9
12	53.6	151.7

°C	°F	R-410A
13	55.4	156.6
14	57.2	161.6
15	59.0	166.7
16	60.8	172.0
17	62.6	177.3
18	64.4	182.8
19	66.2	188.4
20	68.0	194.1
21	69.8	199.9
22	71.6	205.8
23	73.4	211.9
24	75.2	218.1
25	77.0	224.4
26	78.8	230.9
27	80.6	237.5
28	82.4	244.2
29	84.2	251.1
30	86.0	258.0
31	87.8	265.2
32	89.6	272.4
33	91.4	279.8
34	93.2	287.4
35	95.0	295.1
36	96.8	302.9
37	98.6	310.9
38	100.4	319.0
39	102.2	327.3
40	104.0	335.7
41	105.8	344.3

°C	°F	R-410A
42	107.6	353.1
43	109.4	362.0
44	111.2	371.0
45	113.0	380.2
46	114.8	389.6
47	116.6	399.2
48	118.4	408.9
49	120.2	418.8
50	122.0	428.8
51	123.8	439.0
52	125.6	449.4
53	127.4	460.0
54	129.2	470.7
55	131.0	481.6
56	132.8	492.7
57	134.6	504.0
58	136.4	515.5
59	138.2	527.1
60	140.0	539.0
61	141.8	551.0
62	143.6	563.2
63	145.4	575.6
64	147.2	588.2
65	149.0	600.9
66	150.8	613.9
67	152.6	627.1
68	154.4	640.5
69	156.2	654.1
70	158.0	667.8

Values at sea level, add 0.5 psig per 300 m height

# TYPICAL PIPING FOR INDEPENDENT CHILLER

## ADVANTAGES

1. Left and right connection available
2. Accessories included within the equipment:
  - a) 2 Way control valve (Son equipment)
  - b) Flow regulation valve
  - c) Flow switch
  - d) Sectioning valves
  - e) "Y" Filter (Optional)

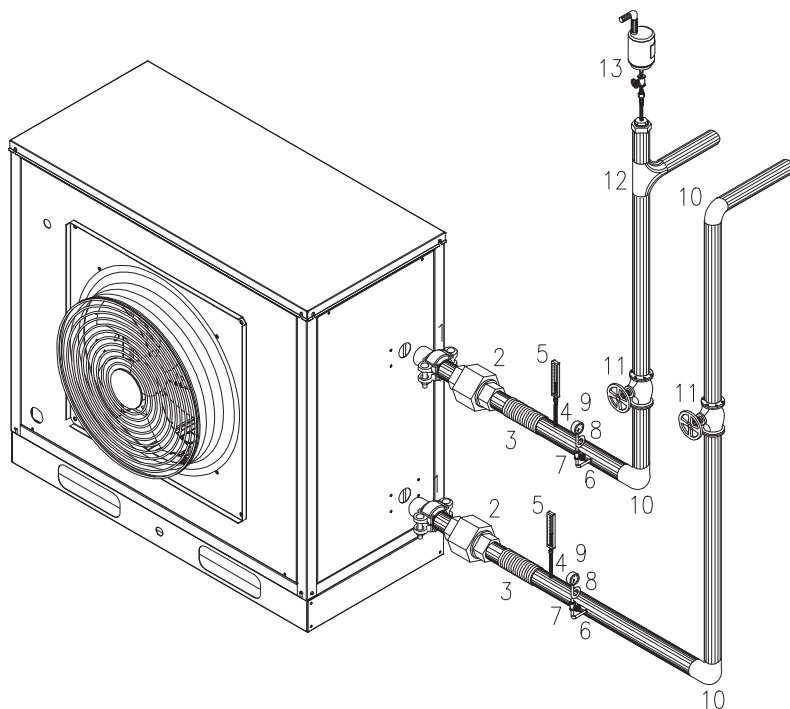

- 1.- CONECTOR ROSCADO
- 2.- TUERCA UNIÓN O BRIDA
- 3.- MANGUERA ANTIVIBRATORIA
- 4.- TERMOPOZO
- 5.- TERMÓMETRO
- 6.- VÁLVULA DE COMPUERTA
- 7.- VÁLVULA DE AGUJA
- 8.- SNUBBER/RIZO
- 9.- MANÓMETRO DE RELOJ
- 10.- CODO DE 90°
- 11.- VÁLVULA DE CIERRE Y/O COMPUERTA
- 12.- TEE
- 13.- VÁLVULA ELIMINADORA DE AIRE

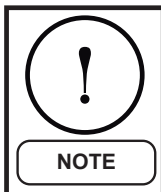

Its recommended that the air purge valve be placed at the highest point of the installation and / or have an air separator tank.

Visually and physically identify the water injection and water return connections in the equipment through the placards "**Water In**" and "**Water Out**".

Due to design changes, your equipment may have a different layout than the one shown on this manual.

## • PREVIOUS TO STARTUP CHECKLIST

The following items must be checked before the unit's startup.

DATE: \_\_\_\_\_

JOBSITE: \_\_\_\_\_

LOCATION: \_\_\_\_\_

INSTALLER CONTRACTOR: \_\_\_\_\_

TECHNICIAN/COMPANY \_\_\_\_\_

STARTING THE UNIT: \_\_\_\_\_

\_\_\_\_\_

UNIT MODEL: \_\_\_\_\_

UNIT SERIAL NUMBER: \_\_\_\_\_



The following procedures are to be considered by the installer; their personnel must be qualified, and certified to perform installation in order to comply all specifications and good practices to assure the correct unit's operation.

## • PHYSICAL INSPECTION (BEFORE ELECTRICAL CONNECTION)

- Check unit for possible transportation or handling damage. \_\_\_\_\_
- Visually check for refrigerant leaks. \_\_\_\_\_
- Only Open unit to install system piping. Do not remove connection's protection until hydraulic circuit is to be closed. \_\_\_\_\_
- Check for foreign objects in fan discharge. \_\_\_\_\_
- Check that air intake is not obstructed and has the required space suggested on Fig. 1 \_\_\_\_\_

## • HYDRAULIC CIRCUIT INSPECTION

The installation of a water filter is necessary on all hydraulic circuits in order to avoid solid particles in it, which must be installed on the return side of the circuit, and cleaned once the system's initial charge is finished.

- Check water filter to be clean. \_\_\_\_\_
- Verify that all service valves are open. \_\_\_\_\_
- Check for adequate makeup of the water supply. \_\_\_\_\_
- Verify that all piping is water full and air has been vented out. \_\_\_\_\_
- Check Thermometers. \_\_\_\_\_
- Check Manometers. \_\_\_\_\_

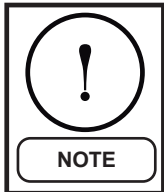

Note: Accessories such as Thermometers, manometers, measuring ports, etc. are recommended but not necessary for the unit's operation.



If hydraulic circuit contains air, it may compromise the units operation.

# ELECTRICAL SUPPLY INSPECTION

The electrical pipes are nipple NPT threaded conduit (1" inch diameter on all models) the units require 3 phase grounded electrical power.

- Verify that the thermo-magnetic switch is of correct capacity for the unit.
- Check that all electrical connections are tight.
- Check for false contacts on ground, and all wiring.
- Check internal connections for control and power.
- Measure voltage on all lines, and ground, neutral, and trifasic line.
- Check for overload protection on motors to be in position to design requirements, and on automatic mode.
- Check voltage monitor control (\*Motor Saver), to be adjusted to supply the correct power voltage for the unit.

---



---



---



---



---



---



\*The unbalance percentage of electrical supply should be calculated with the following formula and adjusted on the UNBALANCE TRIP knob.

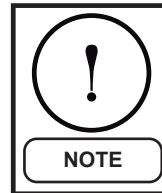

The unit's control panel has a ventilation duct, and it must not be obstructed in any manner.

$$\text{UNBALANCE PORCENTAGE} = \frac{[(\text{MAXIMUM AVERAGE DEVIATION})/(\text{AVERAGE})] \times 100}{1}$$

DIAGNOSIS INDICATING LIGHTS (LED STATUS)	
<b>NORMAL OPERATION</b>	<b>CONSTANT GREEN</b>
<b>START DELAY</b>	<b>INTERMITENT GREEN</b>
<b>INVERTED PHASE</b>	<b>INTERMITENT RED</b>
<b>PHASE UNBALANCED</b>	<b>RED ON LAPSES</b>
<b>HIGH/ LOW VOLTAGE</b>	<b>CONSTANT RED</b>

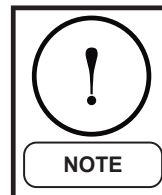

Units are previously factory adjusted however the electrical supply may vary on each installation, and due to this unbalance must be adjusted before startup in order to protect all the unit's motors and electrical components.

## • CONTROL PANEL INSPECTION

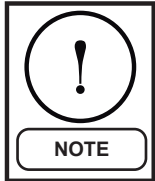

Units are previously factory adjusted however the electrical supply may vary on each installation, and due to this unbalance must be adjusted before startup in order to protect all the unit's motors and electrical components.

- Check the control panel to ensure that it is free of foreign objects. \_\_\_\_\_
- Energize the unit with 3 phase electrical power. \_\_\_\_\_
- Phase unbalance must less than 2% of average. \_\_\_\_\_
- Cycle each fan to assure rotation is correct. \_\_\_\_\_
- Cycle water pump (if applicable) to ensure that it is correctly energized. \_\_\_\_\_

After finishing the inspection of the previous installation points and making sure all the unit's items are correct the unit may be started.

Set the **UNIT CONTROL** switch on the **ON** position (Fig. 15) to energize the control panel with 24 Volts.

## • STARTUP

After energizing the controller, wait five minutes for the unit to be on line and ready. Operation sequence will initiate by checking all security pre-programed points on the unit. If all required conditions are OK the unit will be ready to initiate operation.

### UNIT CONTROL

To start operation set the ON/OFF switch (Fig 15) to the ON position. After six seconds the controller will command the start of the water pump. If water flow is detected on the pipes, the internal sequence of the unit will begin.

### ON / OFF

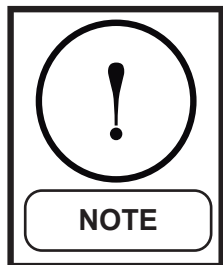

The APG4 switch (Fig. 15) selects the unit's operating mode, whether is it cooling only or heat pump. If you wish to operate the unit as heat pump turn this switch to ON.

## • COMPRESSORS

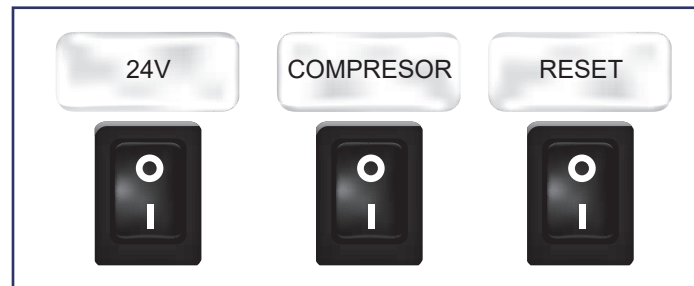

Set the APG1 switch, 24V (Fig. 15) to the ON position afterwards set the APG2 switch also to the ON position, this will enable the compressors start cycle.

Fig. 15. Cooling Only Mode



## • STARTUP RECORD OF THE UNIT

Also, is necessary complete the next information when yo make the startup of the unit.

DATE: \_\_\_\_\_

JOBSITE: \_\_\_\_\_

LOCATION: \_\_\_\_\_

UNIT MODEL: \_\_\_\_\_

SERIAL NUMBER: \_\_\_\_\_

COMPRESSOR MODEL 1: \_\_\_\_\_ SERIAL: \_\_\_\_\_

COMPRESSOR MODEL 2: \_\_\_\_\_ SERIAL: \_\_\_\_\_

COMPRESSOR TYPE 1 (X):        FIXED \_\_\_\_\_ DIGITAL \_\_\_\_\_ VRD \_\_\_\_\_

COMPRESSOR TYPE 2 (X):        FIXED \_\_\_\_\_ DIGITAL \_\_\_\_\_ VRD \_\_\_\_\_

PUMP MODEL 1: \_\_\_\_\_ SERIAL: \_\_\_\_\_

PUMP MODEL 2: \_\_\_\_\_ SERIAL: \_\_\_\_\_

FREQUENCY DRIVER MODEL: \_\_\_\_\_ SERIAL: \_\_\_\_\_

CONTROLLER MODEL: \_\_\_\_\_ SERIAL: \_\_\_\_\_

SOFTWAREVERSION: \_\_\_\_\_

"Y" FILTER (Y/N): \_\_\_\_\_ FLOW SWITCH TYPE (X): ULTRASONIC FLOW SENSOR \_\_\_\_\_ FLOW SWITCH \_\_\_\_\_

NAMEPLATE DATA:    VOLTAGE \_\_\_\_\_        AMPACITY: \_\_\_\_\_        R410A CHARGE: \_\_\_\_\_

SETTINGS:            TEMPERATURE SETTING: \_\_\_\_\_        DELAY: \_\_\_\_\_        UNBALANCE: \_\_\_\_\_

	INITIAL	30 MINUTES	60 MINUTES
OPERATION CAPACITY			
WATER INLET TEMPERATURE			
WATER OUTLET TEMPERATURE			
WATER INLET PRESSURE			
WATER OUTLET PRESSURE			
PUMP VOLTAGE			
PUMP AMPACITY			

	CIRCUIT 1	CIRCUIT 2
SUCTION PRESSURE		
DISCHARGE PRESSURE		
SATURATION SUCTION TEMPERATURE		
SATURATION DISCHARGE TEMPERATURE		
SUPERHEATING		
SUBCOOLING		

		INITIAL		30 MINUTES		60 MINUTES	
		CIRCUIT 1	CIRCUIT 2	CIRCUIT 1	CIRCUIT 2	CIRCUIT 1	CIRCUIT 2
COMPRESSOR	VOLT L1-L2						
	VOLT L1-L3						
	VOLT L2-L3						
	AMP L1						
	AMP L2						
	AMP L3						
OPERATION HOURS							
COMPRESSOR START CYCLES COUNTER							

OIL LEVEL

FAN MOTOR	VOLT L1-L2						
	VOLT L1-L3						
	VOLT L2-L3						
	AMP L1						
	AMP L2						
	AMP L3						
GENERAL UNIT	VOLT L1-L2						
	VOLT L1-L3						
	VOLT L2-L3						
	AMP L1						
	AMP L2						
	AMP L3						
VOLTAGE UMBALANCE							
AMPACITY UMBALANCE							

FREQUENCY DRIVER SETTINGS: \_\_\_\_\_  
 \_\_\_\_\_

RECOMMENDATIONS/COMMENTS: \_\_\_\_\_  
 \_\_\_\_\_

-----  
 CUSTOMER  
 -----  
 -----  
 TECHNICIAN  
 -----

# INSTALLATION



Av. Central No. 285, Parque Logistico,  
Deleg. La Pila, San Luis Potosi, C.P. 78422  
More Info (444) 161.50.43  
**info@clima-flex.com**  
**service@clima-flex.com**  
**ventas@clima-flex.com**  
US Toll Free **01 800 201 48 16**  
Lada sin costo **01 800 890 59 17**

